

# ECE 3600 homework # 9

- 5.7 A 500/200-V, 30-kVA transformer is reconnected as a 700/500-V autotransformer. Compute the new kVA rating of the device.
- Show connections to the following 100/40-V, 200-VA transformers to get the voltage ratios desired. Compute the new VA rating of each connection.

a) 140/40 V

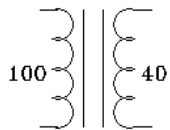

b) 140/100 V

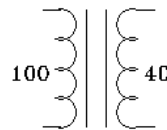

c) 60/40 V

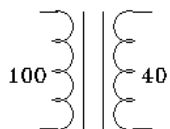

d) 60/100 V

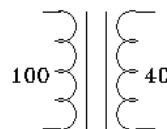

- 5.8 The terminals of a 500/200-V transformer can be interconnected in four different ways, two of which will result in a 700/500-V autotransformer. Assume that you have interconnected the windings in the wrong way, but that you believe that you did it the right way. In other words, you think that you have a 700/500-V autotransformer when in fact you have something else. As you now connect the “700-V terminals” of your device to a 700-V source, you expect to obtain 500-V between what you presume to be the “500-V terminals.” To your surprise you get an entirely different voltage.

a) What voltage do you get?

b) What will happen to your transformer with this kind of treatment?

- a) Draw a per-phase drawing of for the balanced 3-phase, 60-Hz system shown. You may neglect phase issues introduced by Y- $\Delta$  and  $\Delta$ -Y connections. You may need to modify the turns ratio of the transformer to reflect Y- $\Delta$  and  $\Delta$ -Y connections. Be sure to show values of the source, passive components and turns ratio on your drawing.

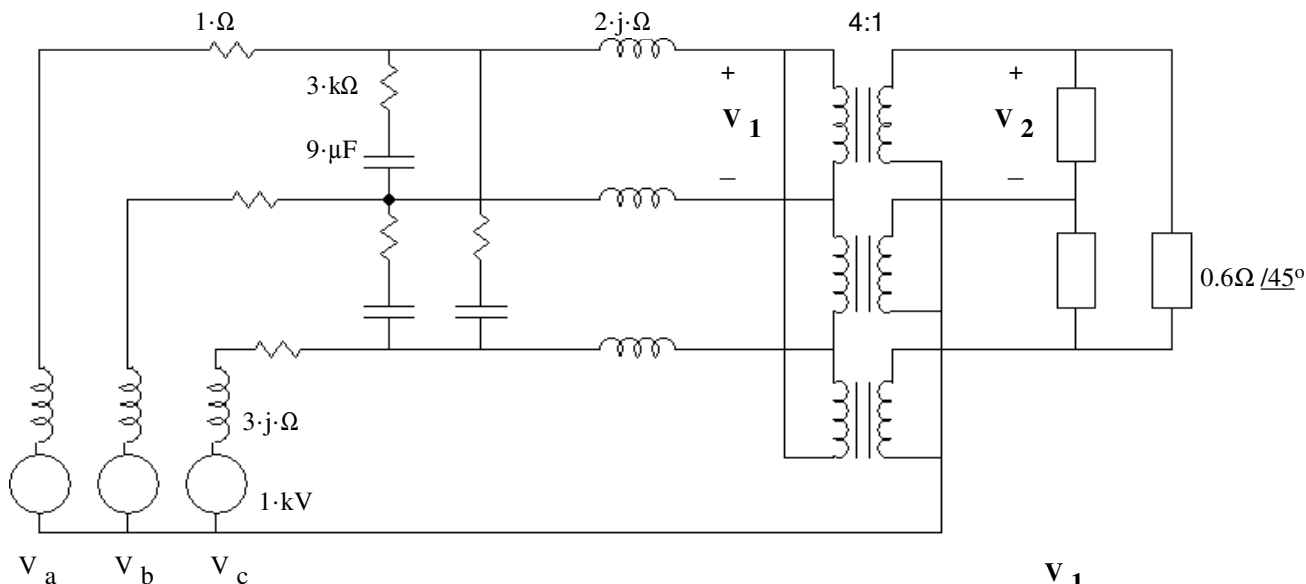

b) Find  $\frac{V_1}{V_2}$  including phase angle

It is easy to see how to transform three-phase power with the use of three single-phase transformers, but there are two ways to transform three-phase power using only two single-phase transformers. The next two problems investigate these methods. In them, we will transform 480 V three phase to 240 V three phase; hence, the transformers have a turns ratio of 2:1. Hint: In both figures, the geometric orientation hints of the phasor relationships.

5. The configuration shown is called the "open-delta" or "V" connection, for obvious reasons. Identical 2:1 transformers are used.

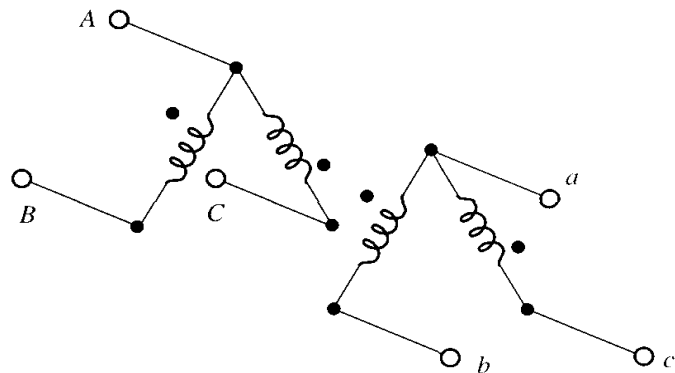

a) Show that if ABC is 480-V balanced three phase, abc is 240-V balanced three-phase. Consider the ABC voltages to be a three-phase set and prove the abc set is three-phase.

b) If the load is 30 kVA, find the required kVA rating of the transformers to avoid overload. [You can solve this independent of part a)]

6. 1.22. The configuration shown is called the "T" connection. For this connection, the 2:1 transformers are not identical but have different voltage and kVA ratings. The bottom transformer is center-tapped so as to have equal, in-phase voltages for each half.

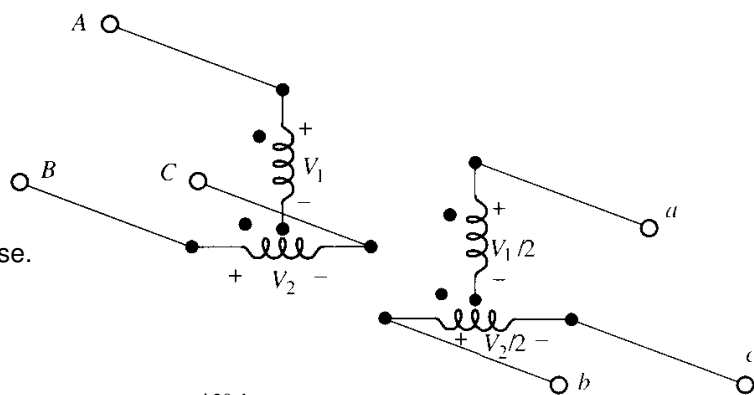

a) Find the voltages  $V_1$  and  $V_2$  to make this transform 480-V to 240-V balanced three-phase.

b) If the load is 30 kVA, find the required kVA rating of each transformer to avoid overload.

7. A phase-shifting transformer has a complex turns ratio of  $t := 4 \cdot e^{j20\text{deg}} = 4 / 20^\circ$

It has a series impedance of  $Z_S := (0.05 + j \cdot 0.6) \cdot \Omega$

Find the admittance matrix of this transformer (see the last page of the transformer notes).

**Answers**

1. 105-kVA    2. a) 140/40 V

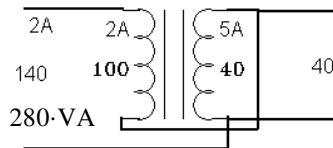

b) 140/100 V

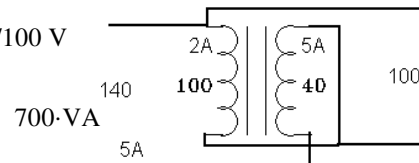

3. a) 1167-V

b) The smoke gets out

c) 60/40 V

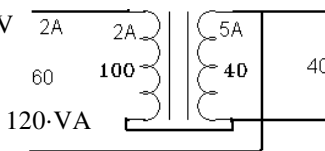

d) 60/100 V

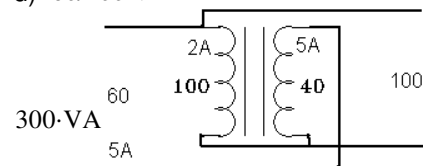

4.  $1 \cdot \Omega$      $2 \cdot j \cdot \Omega$     2.31:1

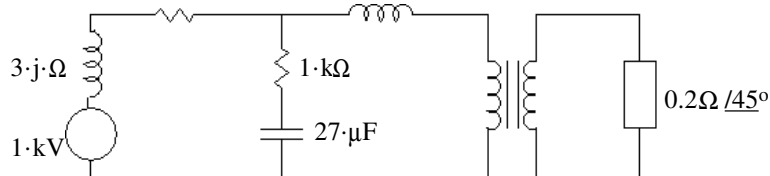

b) 2.309 / -30°

5. a) Calculate  $V_{bc}$  from the other two voltages and show that it has the correct magnitude and correct phase angle.

b) 17.3-kVA per transformer, 34.6-kVA for both

6. a) 415.7-V    480-V    b) 15-kVA    17.3-kVA    32.3-kVA for both

7.  $\begin{pmatrix} 0.138 - 1.655j & 0.109 + 0.401j \\ -0.174 + 0.377j & 8.621 \cdot 10^{-3} - 0.103j \end{pmatrix} \cdot \frac{1}{\Omega}$