

# ECE 3600 Homework # 3B

e

1. In the circuit shown, the voltmeter measures 120V and the ammeter measures 6.3A (recall that AC meters read RMS). The wattmeter measures 560W. The load consists of a resistor and an inductor. The frequency is 60Hz. Find the following:

- Power factor
- Leading or lagging?
- Real power.
- Apparent power.
- Reactive power.
- Draw a phasor diagram.
- The load is in a box which cannot be opened. Add another component to the circuit above to correct the power factor (make  $pf = 1$ ). Draw the correct component in the correct place and find its value. This component should not affect the real power consumption of the load.
- Find the new readings of voltmeter, ammeter, and wattmeter.

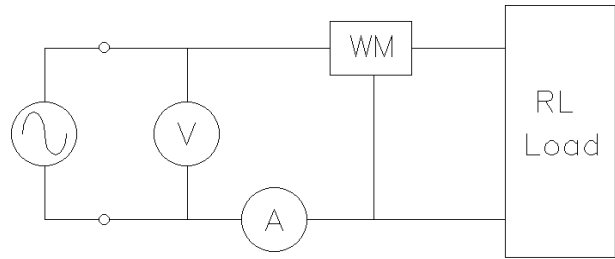

2. For the circuit shown, find the following: (as always, give the correct units)

- The complex power.
- Real power.
- Reactive power.
- Apparent power.
- Draw a power phasor diagram.

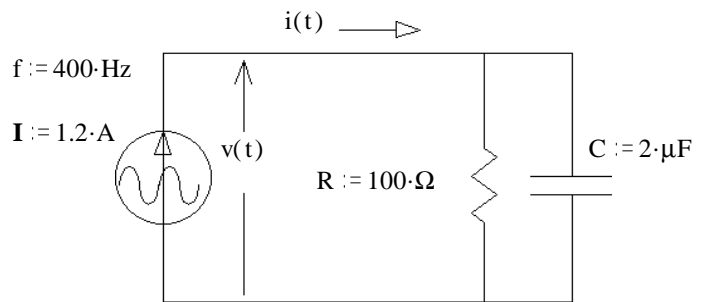

3. A load draws 12kVA at 0.8 pf, lagging when hooked to 480V. A capacitance is hooked in parallel with the load and the power factor is corrected to 0.9, lagging.

- Find the reactive power (VAR) of the capacitor. Draw a phasor diagram as part of the solution.
- Find the value of the capacitor assuming  $f = 60\text{Hz}$ .

4. R, L, & C together are the load (in dotted box). The power used by the load is  $P_{\text{Load}} := 726\text{-W}$  Find:

- The reactive power used by the load.  $Q = ?$
- If you can't find this Q, try parts e) and f) first and then come back to part a).
- The apparent power of the load.  $|S| = S = ?$
- The power factor of the load.  $pf = ?$
- Is the power factor i) leading? ii) lagging?
- The voltage at the load (magnitude).  $V_{\text{Load}} = ?$

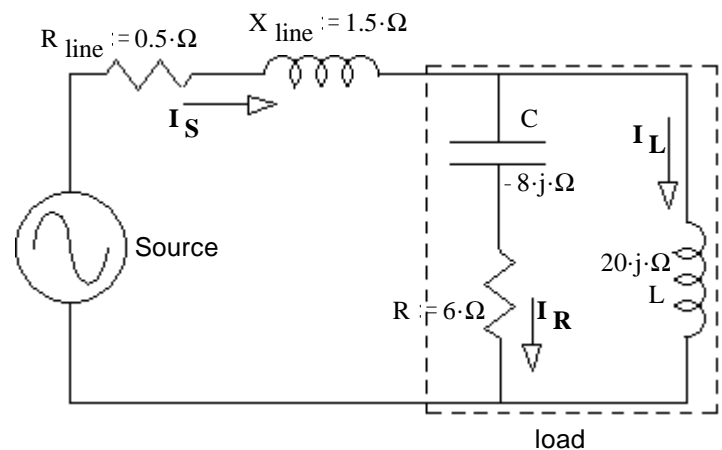

- The magnitudes of the three currents.  $|I_R| = ?$   $|I_L| = ?$   $|I_S| = ?$
- The source voltage (magnitude).  $V_S = ?$
- Is there something weird about this voltage? If so, what? Why?
- The efficiency.  $\eta = ?$

When asked for efficiency, assume the power used by  $R_{\text{line}}$  is a loss and  $P_{\text{load}}$  is the output power.

# ECE 3600 Homework # 3B p2

5. (40 pts) A capacitor (C, shown below) is used to partially correct the power factor of a load to 0.9.  $A_1$  and  $A_2$  are ideal ammeters.  $V_1$  and  $V_2$  are ideal voltmeters. The load uses 720W. Find the following:

- a) The RMS readings of the two ideal ammeters.

$I_{A1} = ?$                        $I_{A2} = ?$

Hint: there are a number of steps involved here. For  $A_1$ , do calculations on the load and cap together. For  $A_2$  you'll need numbers for the load alone.

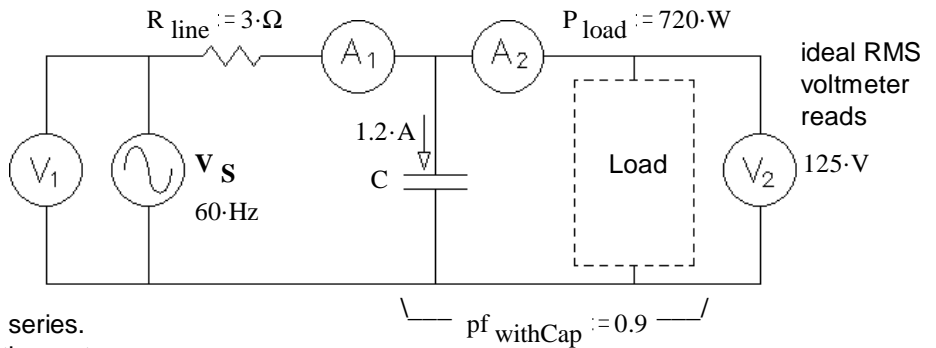

- b) The load can be modeled as 2 parts in series. Draw the model and find the values of the parts.  
 c) The voltage measured by the ideal voltmeter, labeled  $V_1$ .  $V_1 = ?$

- d) The efficiency.  $\eta = ?$

Assume the power used by  $R_{line}$  is loss and  $P_{load}$  is the output power.

$$\eta = \frac{P_{out}}{P_{in}} = \frac{P_{out}}{P_{out} + P_{loss}}$$

- e) Add an additional component to the drawing above in order to completely correct the power factor. Find the value of the component.  
 f) Without making any additional calculations, would the efficiency be better or worse with the added component of part e)? i) higher  $\eta$  ii) lower  $\eta$  iii) could be either iv) no difference

## Answers

1. a) 0.741

- b) lagging

- c) 560-W

- d) 756-VA

- e) 508-VAR

- f) ----->

- g) 93.6- $\mu$ F

- h) 120-V    4.67-A    560-W

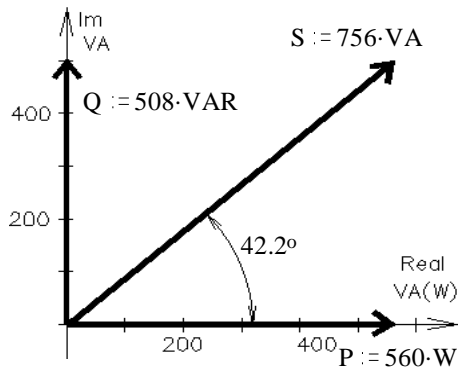

Draw a capacitor in parallel with load

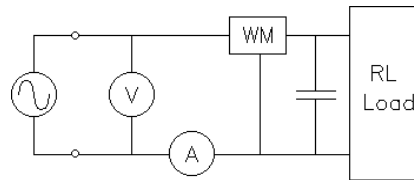

2. a)  $(115 - 57.8j) \cdot VA$

- b) 115-W

- c) -57.8-VAR

- d) 128.7-VA

- e) ----->

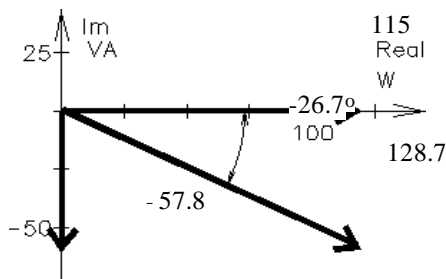

3. a) -2.55-kVA

- b) 29.4- $\mu$ F

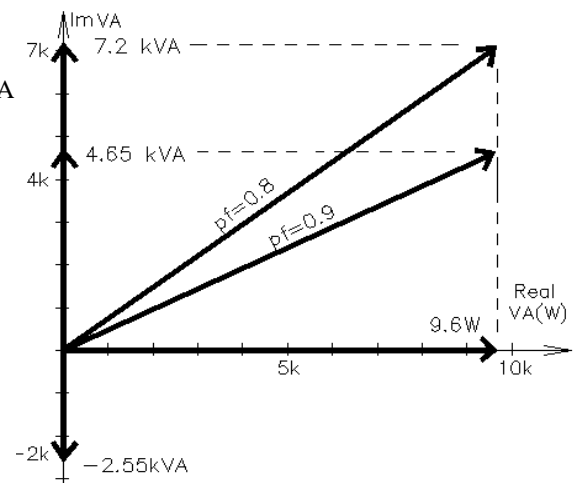

4. a) -363-VAR    b) 812-VA    c) 0.894    d) i)    e) 110-V    f) 11-A    5.5-A    7.38-A    g) 109-V

h)  $V_S$  is less than  $V_{Load}$  Because the Q of the line partially cancels the Q of the load    i) 96.4%

5. a)  $I_{A1} = 6.4-A$      $I_{A2} = 7.01-A$     b)  $R = 14.67-\Omega$      $L = 26.9-mH$     c) 142.5-V

- d) 85.4%    e) 59.2- $\mu$ F in parallel with existing C    f) i)