

Simplified Drawing of a Motor or Generator (Exploded view)

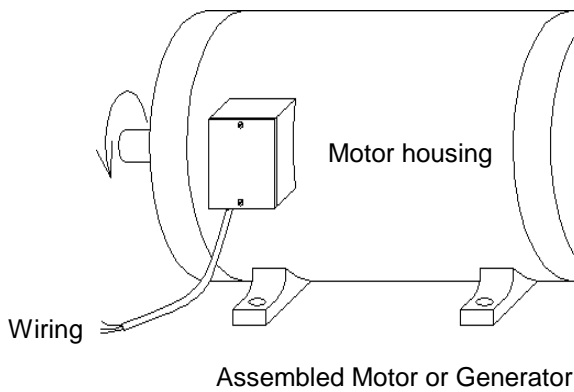
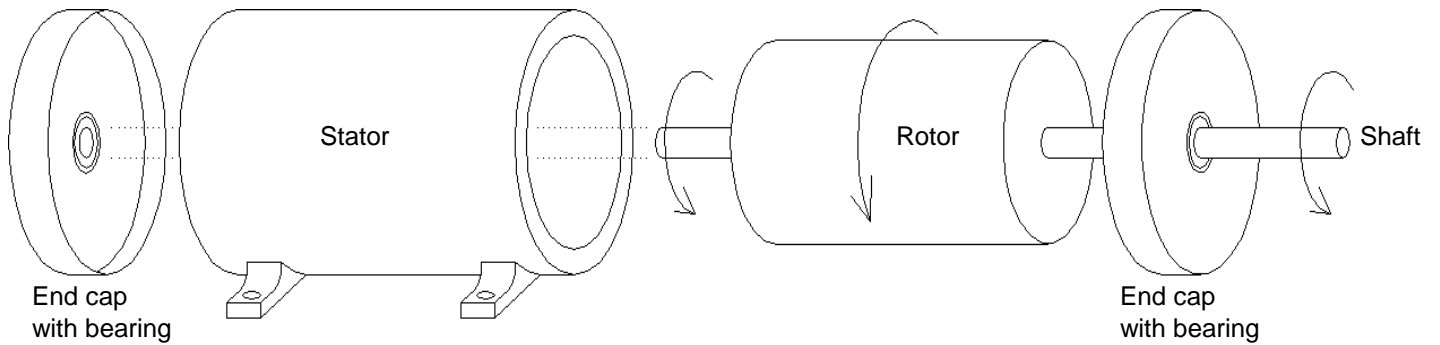

Torque  $T$  or  $\tau$ , N·m

Angular Velocity  $\omega$ ,  $\frac{\text{rad}}{\text{sec}}$  or  $n$ ,  $\frac{\text{rev}}{\text{min}}$  or rpm

Angular Acceleration  $\alpha$ ,  $\frac{\text{rad}}{\text{sec}^2}$

Output power (mechanical)  $P_{\text{shaft}}$  or  $P_{\text{out}}$  W or hp (horse power)

The only way to get output power is to attach the motor shaft to a mechanical load.

$= \tau \cdot \omega$

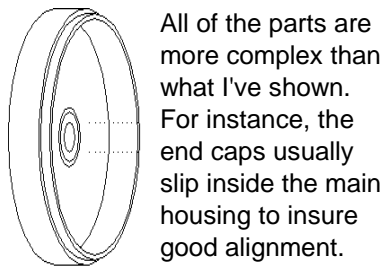

All of the parts are more complex than what I've shown. For instance, the end caps usually slip inside the main housing to insure good alignment.

Many drawings of motors, especially those designed to show how the motor works, show the motor from one end and only show the most important parts.

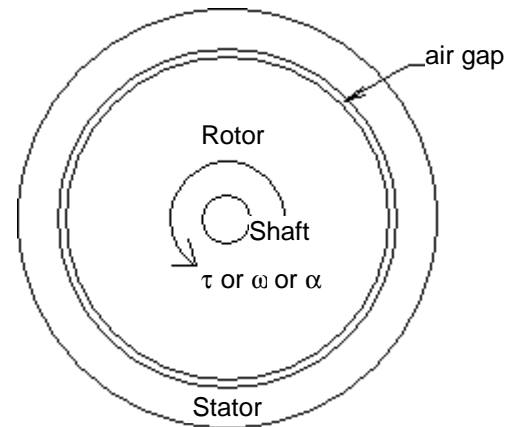

This is, of course, an electrical device, so it needs some wiring,

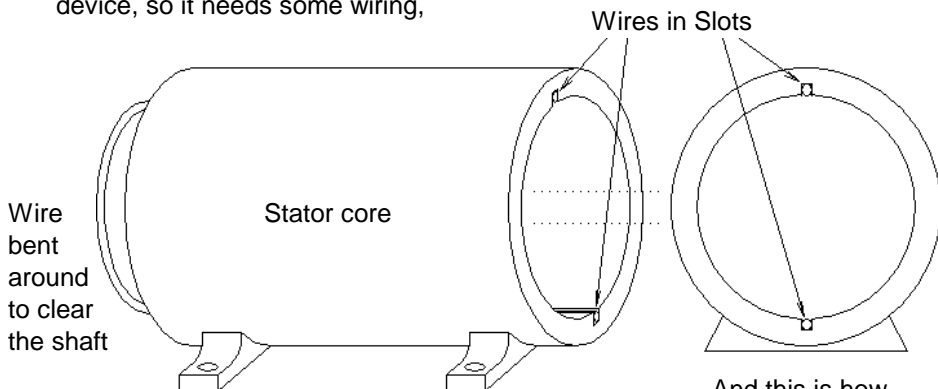

And this is how details will be shown

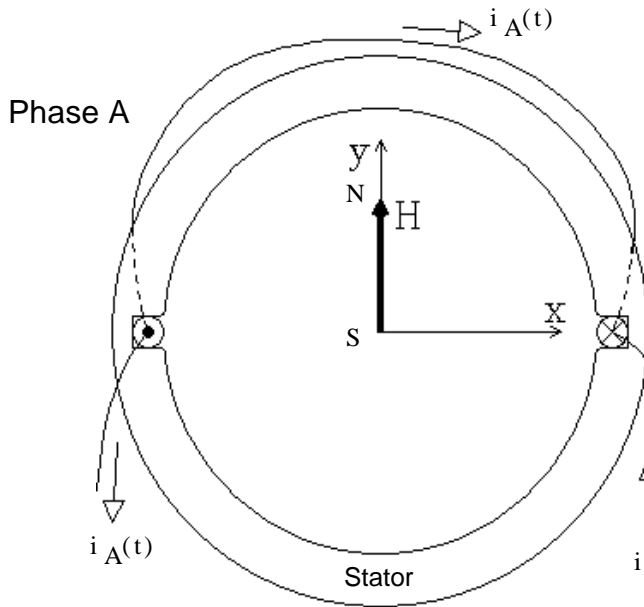

It is also an electromagnetic device  
Establishing a Rotating Magnetic Field

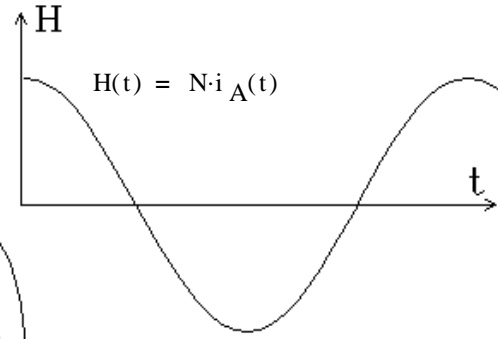

Field goes up and down, but no rotation

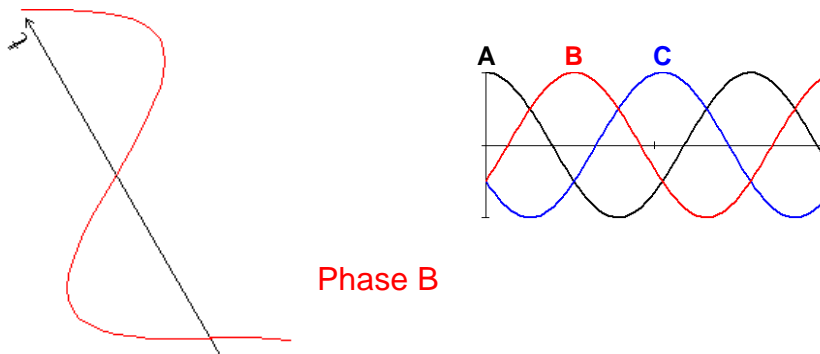

Phase B

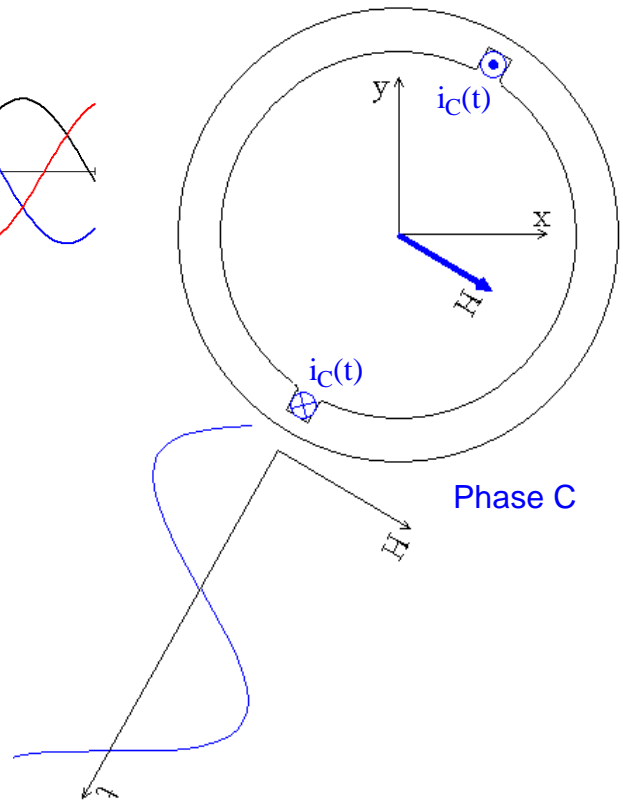
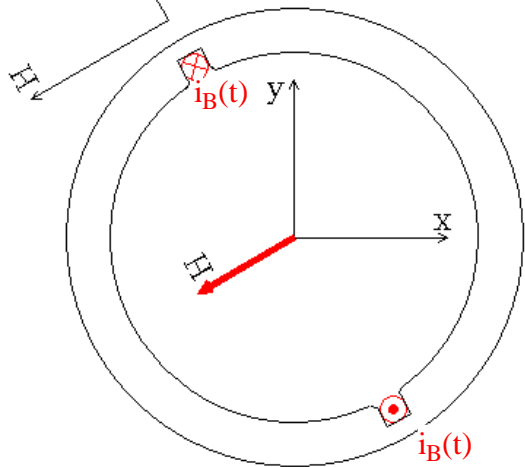

Phase C

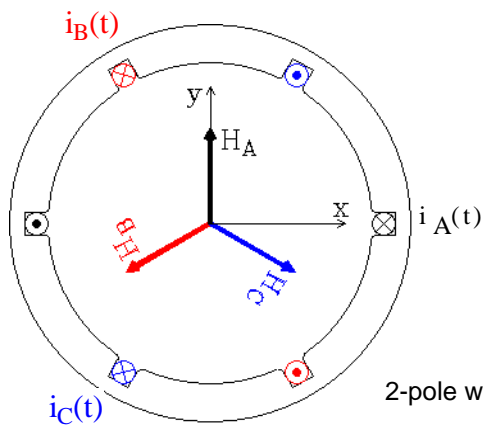

2-pole windings

All 3 phases create a counterclockwise rotating magnetic field.

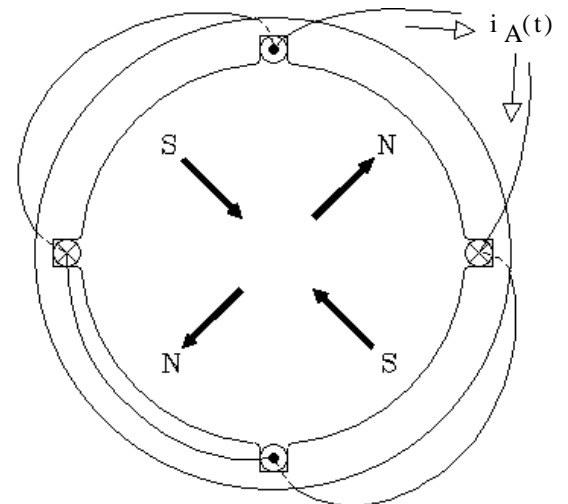

Phase A of a 4-pole winding

Speed of the Rotating Magnetic Field

Depends on the number of poles  $\omega = \frac{4 \cdot \pi \cdot f}{N_{\text{poles}}} = \frac{2 \cdot \left( 377 \cdot \frac{\text{rad}}{\text{sec}} \right)}{N_{\text{poles}}}$  for 60Hz systems

OR,  $n_m$  or  $n_{\text{sync}} = \frac{f \cdot \frac{2 \cdot \text{poles} \cdot 60 \cdot \text{sec}}{\text{cyc} \cdot \text{min}}}{N_{\text{poles}}} = \frac{7200 \cdot \text{rpm}}{N_{\text{poles}}}$  for 60Hz systems

The same stator windings are used for 3-phase Synchronous Machines and for Induction Motors.

In Synchronous Machines the stator is often called the "armature".

## Synchronous Generators & Motors

**Rotor** The rotors in Synchronous Machines are magnets which want to follow the rotating magnetic fields, usually DC electromagnets. The DC current usually flows through brushes and slip rings to reach the moving rotor. Sometimes the field current is generated and rectified right on the rotor. This DC field current is called the field current ( $I_f$ ).

Two types of rotors:

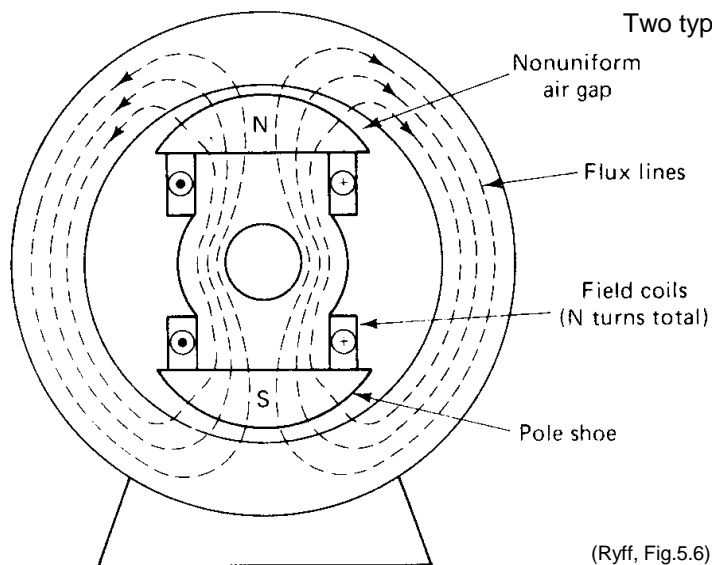

**2 Salient poles**

Common for a motor or generator with many poles

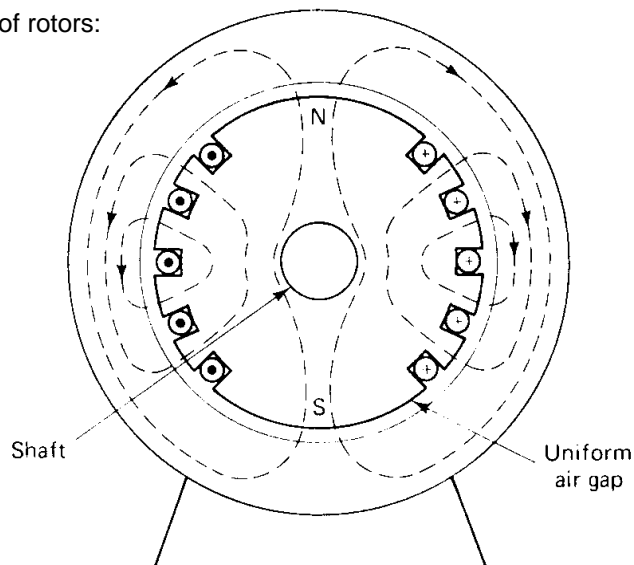

**2 Non-salient poles, Cylindrical rotor**

Common for a motor or generator with few poles

10-pole example

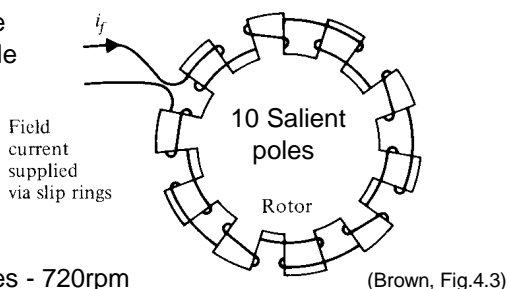

10-poles - 720rpm  
(fast for hydro)

Typically low-speed motor or water turbine driven generator. Typically short in length and large in diameter. (typ diameter is 1.5xlength)

(Brown, Fig.4.3)

Sometimes shown this way:

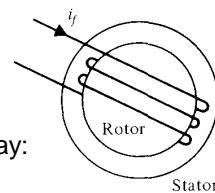

(Brown, Fig.4.2)

Typically high-speed motor or steam turbine driven generator, long and small diameter. (typ length is 3xdiameter)

2-poles - 3600rpm      4-poles - 1800rpm

## Motor

If the stator currents flow in from a 3-phase power source and the rotor is a magnet, the rotor will follow the rotating magnetic field at the synchronous speed (in sync with the rotating field). That would be a synchronous motor. However, when the magnetic rotor is spinning within the stator windings it will induce voltages on those windings, just like a generator. The induced voltages (called the back EMF,  $E_A$ ) will oppose the input voltages that caused the original currents to flow.

When the motor shaft is connected to a mechanical load (spins something which resists spinning), the rotor tries to slow down, but it only succeeds in lagging behind the rotating magnetic field a little (unless the motor is overloaded). When the rotor lags behind the field, the induced voltages ( $E_A$ 's) will also lag the input voltages.

# Generator

If, instead of a mechanical load, the shaft of this same device is connected to a source of mechanical power which tries to make it spin faster than the synchronous speed, it will act as a generator. If the generator is connected to the power grid (as they usually are) the only way the mechanical power source (the prime mover) can increase the speed would be to push the frequency of the entire grid higher than 60 Hz -- not likely. So all it succeeds in doing is to make the rotor lead the rotating magnetic field a little and along with it the induced voltages ( $E_A$ )s will also lead the grid voltages..

Phasor diagrams of one phase.

We usually consider the the terminal or phase voltage ( $V_\phi$ ) be set and held constant by the entire power grid.

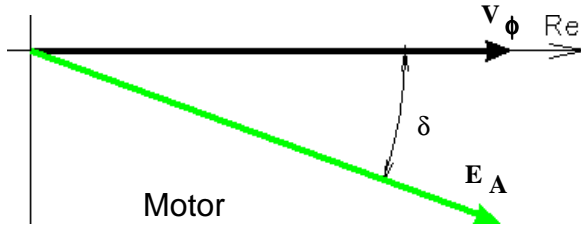

When operated as a motor, the induced armature voltage ( $E_A$ ) lags the terminal voltage,  $V_\phi$ .

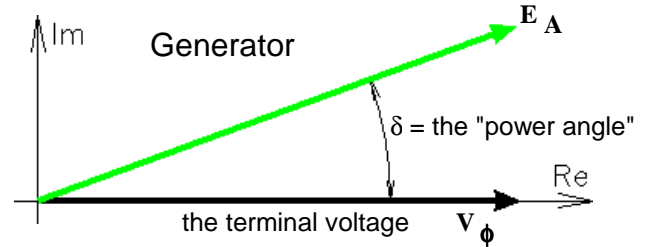

When operated as a generator, the induced armature voltage ( $E_A$ ) leads the terminal voltage,  $V_\phi$ .

The magnitude of the induced armature voltages ( $E_A$  for our phase) depends on the field current,  $I_f$ .  $I_f$  causes the field flux (called **excitation**). The DC current may come from an external supply or it may be generated on the rotor. Either way there are usually brushes and slip rings, if not for DC current, then for control of that current.

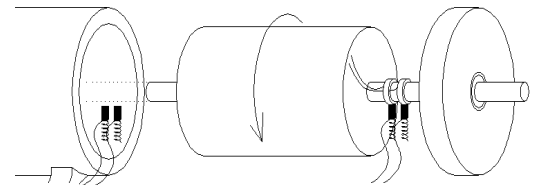

Slip rings and brushes used to connect a DC supply to the rotor. (brushes shown twice)

## Synchronous Generators

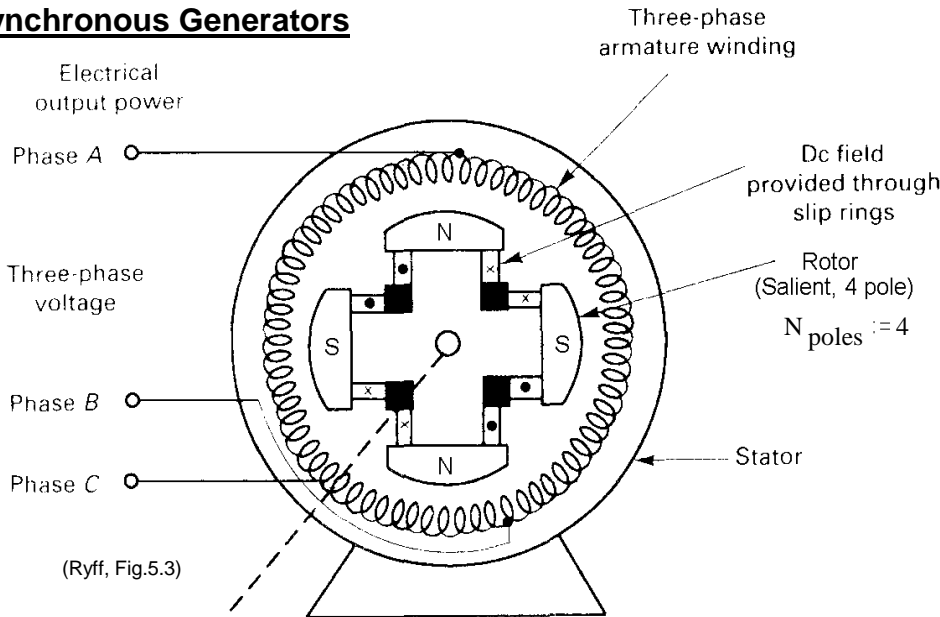

$$\omega = \frac{377 \cdot \frac{\text{rad}}{\text{sec}}}{2} = 188.5 \cdot \frac{\text{rad}}{\text{sec}}$$

$$n = \frac{7200 \cdot \text{rpm}}{4} = 1800 \cdot \text{rpm}$$

Mechanical input power = Torque x  $\omega$   
 Prime mover (mechanical input power)

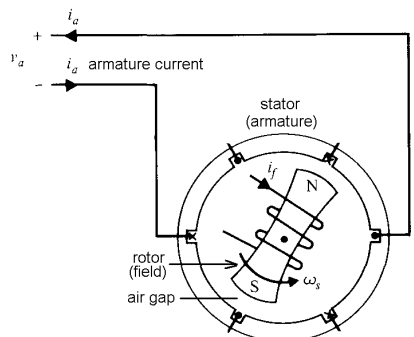

Stator (armature) winding

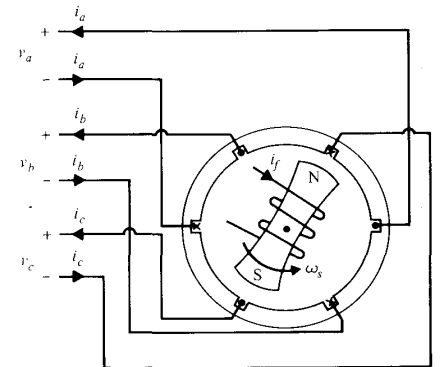

2-pole, 3-phase synchronous generator

(Brown, Fig.4.1)

## Electrical analysis on a per-phase basis

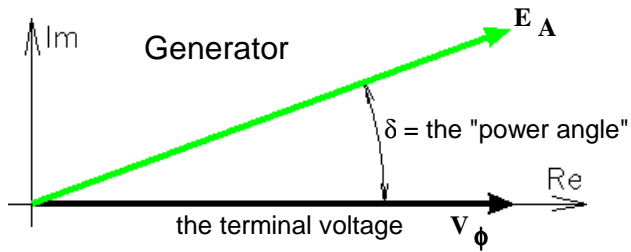

When operated as a generator, the induced armature voltage ( $E_A$ ) leads the terminal voltage,  $V_\phi$ .

The magnitude  $E_A$  depends on the DC field current,  $I_f$ .

### The electrical model of an armature winding

$X_s$  is the armature inductance  
(armature windings and leakage  
(magnetization))

$R_s$  is the armature winding resistance

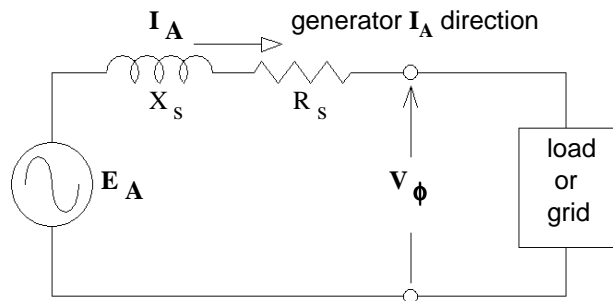

This is almost always simplified to this:  
(Especially in our class)

$$E_A = I_A \cdot j \cdot X_s + V_\phi$$

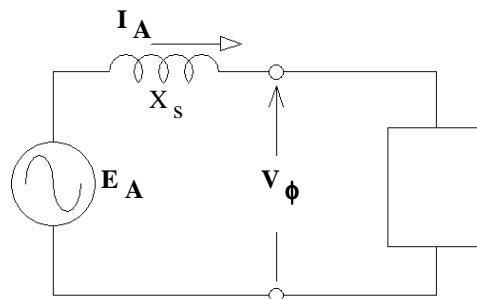

### Low, or Under-excited

Low DC field current

Low  $E_A$

Makes -Q

"Uses" Q like an  
inductive load

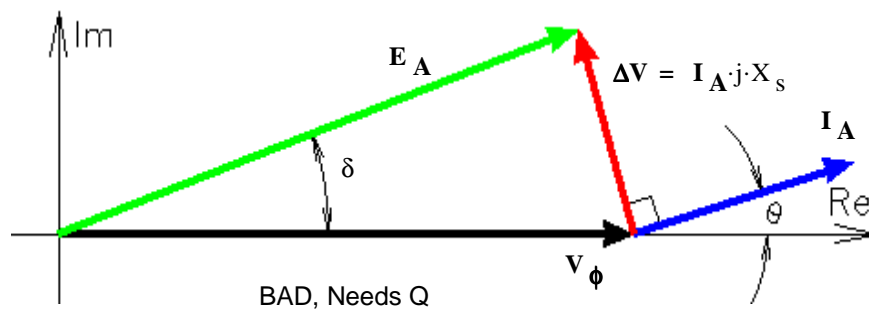

The **under-excited** condition, the current leads the terminal voltage,  $V_\phi$ . The generator supplies -Q (-VARs), that is, it absorbs +Q (+VARs), just like an inductive load. Usually not desirable.

### High, or Over-excited

Higher DC field current

High  $E_A$

Makes Q

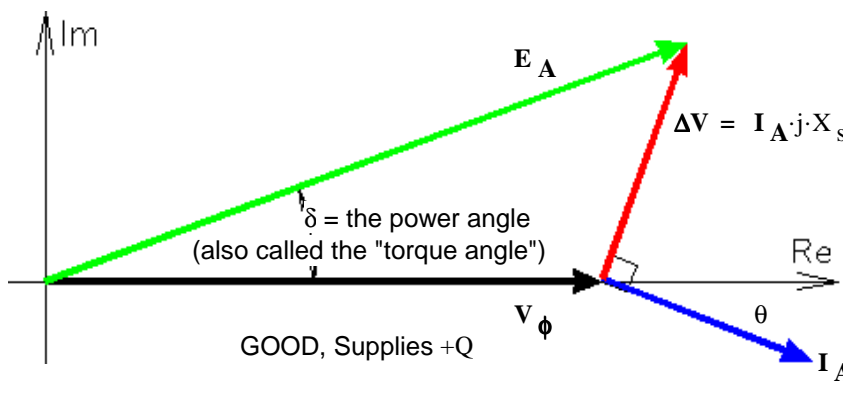

$I_A = \frac{\Delta V}{j \cdot X_s}$  current lags, matching the  
need of most loads

The **over-excited** condition, the current lags the terminal voltage,  $V_\phi$ . The generator supplies +Q (+VARs), that is, it absorbs -Q (-VARs), just like a capacitive load. Usually desirable.

## Important relations

Note: Voltages and currents are magnitudes, not complex numbers

The **signs** of the angles are **important!**

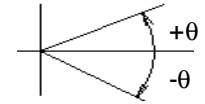
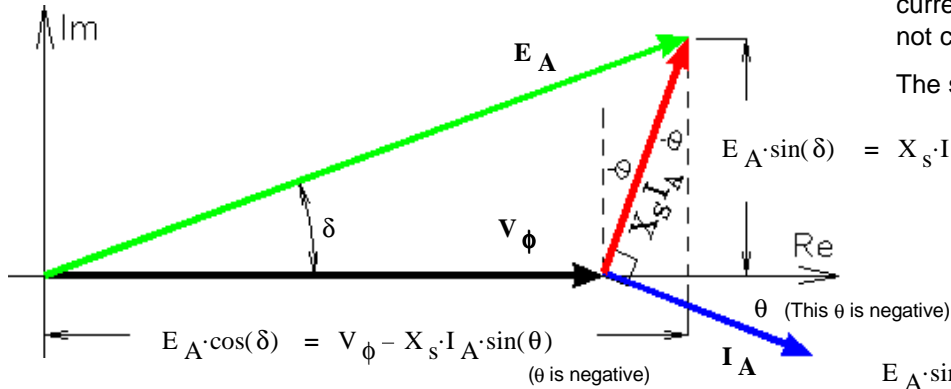

$$-I_A \cdot \sin(\theta) = \frac{E_A \cdot \cos(\delta) - V_\phi}{X_s}$$

$$E_A \cdot \sin(\delta) = X_s \cdot I_A \cdot \cos(\theta) \quad <----$$

$$I_A \cdot \cos(\theta) = \frac{E_A \cdot \sin(\delta)}{X_s}$$

$$Q_{1\phi} = -V_\phi \cdot I_A \cdot \sin(\theta)$$

$$P_{1\phi} = V_\phi \cdot I_A \cdot \cos(\theta)$$

$$----> \quad Q_{1\phi} = \frac{V_\phi \cdot E_A \cdot \cos(\delta) - V_\phi^2}{X_s}$$

$$P_{1\phi} = \frac{V_\phi \cdot E_A \cdot \sin(\delta)}{X_s} \quad <----$$

$$\delta = \text{asin}\left(\frac{P_{1\phi} \cdot X_s}{V_\phi \cdot E_A}\right) \quad <----$$

$$\text{asin} = \sin^{-1}$$

## Pullout power

If  $\delta$  reaches  $90^\circ$ , the generator will lose synchronization.

Pullout power is the maximum power a generator can produce for a given excitation, at  $\delta := 90\text{-deg}$

$$P_{po} = \frac{E_A \cdot V_\phi}{X_s} \cdot \sin(90\text{-deg}) = \frac{E_A \cdot V_\phi}{X_s}$$

## To Bring a Synchronous Generator "On Line"

1. Bring speed to the correct rpm so that the generator frequency matches the line frequency.
2. Adjust the field current,  $I_f$  so that the generator voltage matches the line voltage.
3. Readjust speed if necessary, check that the phases are in the correct sequence if necessary.
4. Wait until the phases align (0 volts difference between generator terminal and the line phase). Connect to the line at just the right moment.
5. Increase input torque to produce real electrical power and field current to produce reactive power.

Most (~99%) of the world's electrical energy is produced by 3-phase synchronous generators.

## Mechanical speed, torque, and power

$$\text{Shaft speed in rad/sec} \quad \omega_{\text{mech}} = \frac{4 \cdot \pi \cdot f}{N_{\text{poles}}} = \frac{2 \cdot \left(377 \cdot \frac{\text{rad}}{\text{sec}}\right)}{N_{\text{poles}}} \quad \text{for 60Hz systems}$$

$$\text{Shaft speed in rev/min} \quad n = \frac{f \cdot \frac{2 \cdot \text{poles} \cdot 60 \cdot \text{sec}}{\text{cyc} \cdot \text{min}}}{N_{\text{poles}}} = \frac{7200 \cdot \text{rpm}}{\text{poles}} \quad \text{for 60Hz systems}$$

$$\tau_{\text{mech}} \cdot \omega_{\text{mech}} = P_{3\phi} \quad (\text{electrical}) \quad \text{neglecting losses}$$

$$\tau_{\text{mech}} = \text{mechanical torque}$$

**Synchronous Motors**

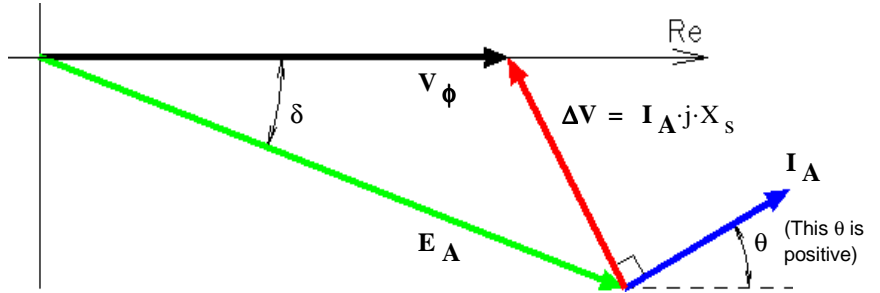
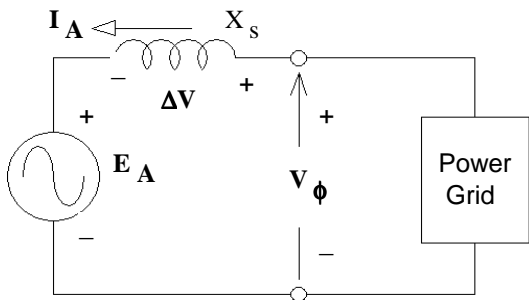

**Over-excited condition, GOOD, supplies +Q (+VARs).**

(θ is measured in opposite direction to a regular load)

$$Q_{1\phi} = V_{\phi} \cdot I_A \cdot \sin(-\theta)$$

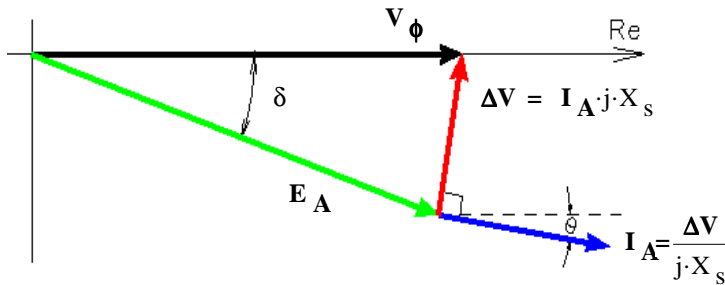

**Under-excited condition, BAD, absorbs +Q (+VARs).**

Important relations

$$E_A \cdot \sin(|\delta|) = X_s \cdot I_A \cdot \cos(\theta)$$

$$P_{1\phi} = \frac{E_A \cdot V_{\phi}}{X_s} \cdot \sin(|\delta|)$$

$$Q_{1\phi} = \frac{V_{\phi}^2 - E_A \cdot V_{\phi} \cdot \cos(\delta)}{X_s} \quad (\text{Bigger } E_A \text{ makes } Q \text{ negative (good)})$$

$$= V_{\phi} \cdot I_A \cdot \sin(-\theta)$$

**Synchronous Condenser (Capacitor)**

A special case of the over-excited motor with no mechanical load (and neglecting friction)

An under-excited motor with no mechanical load (and neglecting friction) will look like an inductor. Called synchronous reactance.

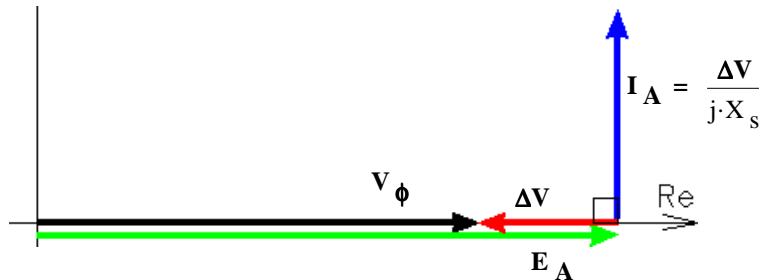

**Motor Connections and Changing the Direction of Rotation**

DO NOT alter the manufacturer's wiring within the motor, other than to change from Y to Δ or reverse. And then follow directions carefully. Otherwise something like this could happen:

It is OK to change the connections between the power panel and the motor as long as you don't mess with the neutral and/or ground connections. Swapping any two phases from the power panel will reverse the direction of rotation. Works for both Y and Δ connections

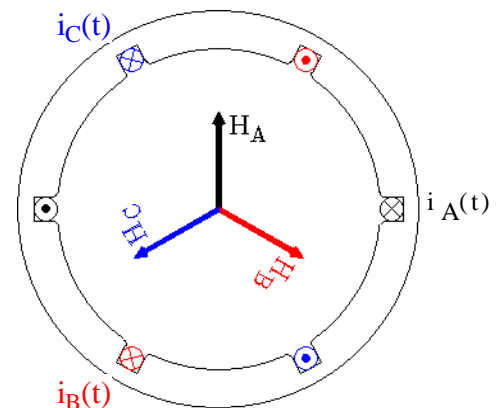
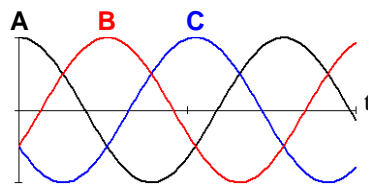
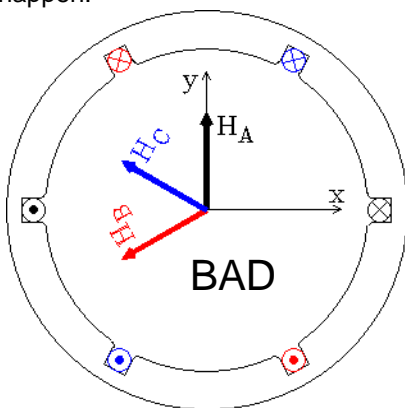

The 3 phases create a clockwise rotating magnetic field.

In steady-state synchronous operation, the rotor of a synchronous machine does not experience a changing magnetic flux so there are no core losses in the rotor and it can be made of solid ferromagnetic material. The stator, on the other hand, *does* experience a changing magnetic flux (at 60 Hz) so there are both hysteresis and eddy-current core losses in the stator. The stator is constructed of laminated, siliconized material to minimize the eddy currents.

### Stator windings in practice

The nonlinearity of the stator core also causes the stator current to be nonsinusoidal, including a significant third-harmonic (just like in a transformer). To reduce the harmonics, the phase windings are designed to overlap each other a little and don't always span exactly 180° of flux.

### Effect on the network (grid)

Our analysis regularly assumes that the generator feeds an "infinite" network bus. Then we can assume the network voltage, or the terminal voltage, is constant in magnitude, frequency and phase (The slack-bus idea). In reality, large generators *do* affect the network (the larger the generator, the larger the effect). Increasing the prime-mover torque will raise the network voltage (especially in the local area) and slightly increase the entire network frequency. Matching the generation of reactive power to the local needs will help to optimize the network power flow.

### Damper Bars

The rotor of an *induction* motor includes a number of thick conductors called "rotor bars". Current is induced in these bars because the rotor normally turns at speed which is slower than the synchronous speed (the speed of the rotating flux caused by the stator windings). The interaction between the induced current and the rotating flux provides the motor torque.

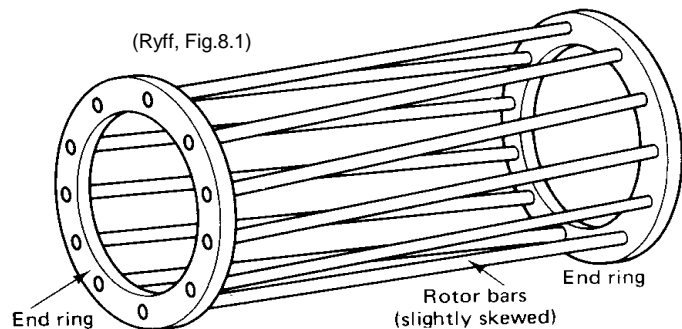

Synchronous machines usually have very similar bars in their rotors. In steady-state synchronous operation, they have no effect. The purpose of these bars is to resist, or dampen, transients. Currents will be induced in these windings when the stator current magnitudes change or when the input rotational shaft speed changes. By Lenz's law, those currents will be induced in a direction to oppose the change that caused them. In solid iron rotors, the eddy currents have the same effect. Without damping, the shaft speed can oscillate.

See textbook section 5.11, p.243 for more details.

See also textbook  
fig 5.41, p.245

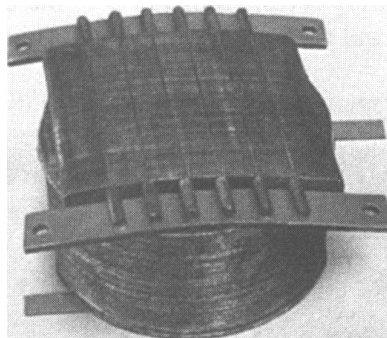

(Ryff, Fig.10.3)

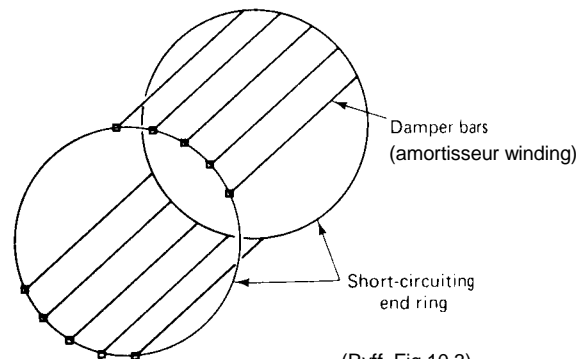

(Ryff, Fig.10.3)

Note: These notes and Chapter 5 of our textbook assumes that the DC supply of the field current is robust enough to withstand high voltage transients. It also assumes the source resistance and the field winding resistance are so small that the field winding itself can perform the transient damping function. It is more reasonable to assume that the synchronous machine is constructed with damper bars, but the results of the different assumptions is about the same.