

ECE 3600 Single-Phase Induction Motors

A Stolp 10/23/20

A single-phase winding on the stator of an induction motor.

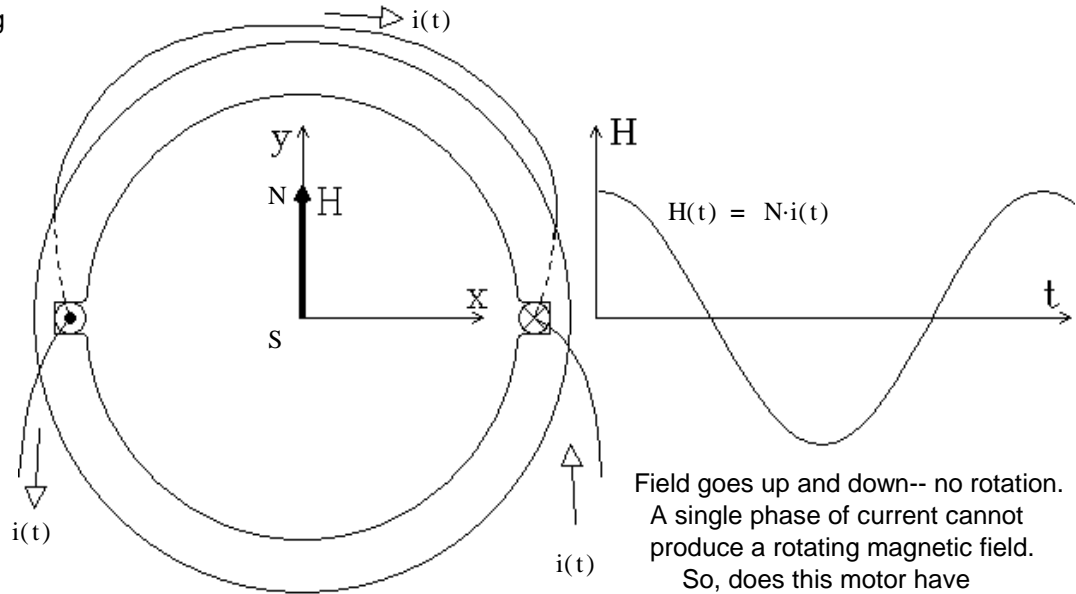

Field goes up and down-- no rotation. A single phase of current cannot produce a rotating magnetic field. So, does this motor have a torque-speed curve??

Yes it does. Think of the magnetic intensity vector, H , as being made up of two vectors half as large and rotating in opposite directions. The green (CCW) vector and the blue (CW) vectors shown below add up to be the H vector.

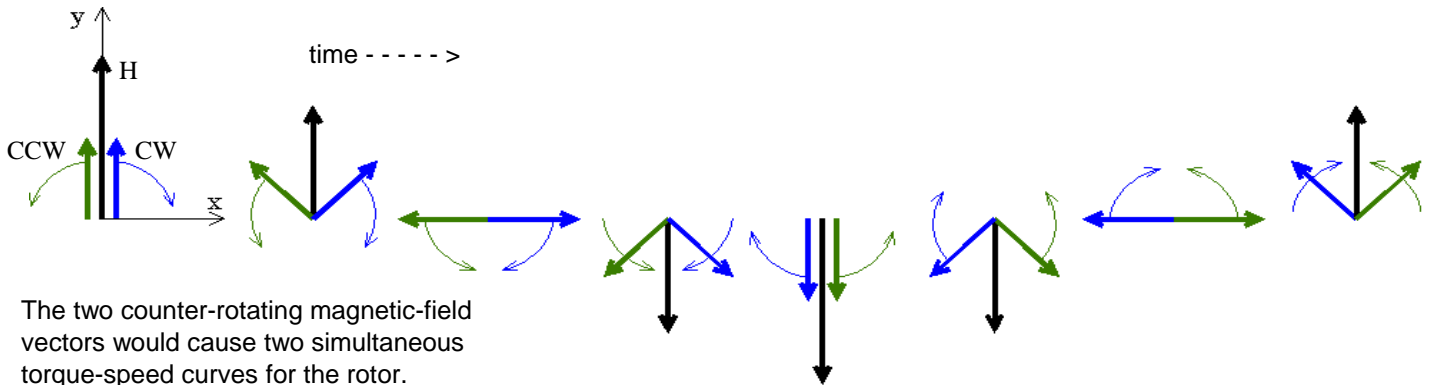

The two counter-rotating magnetic-field vectors would cause two simultaneous torque-speed curves for the rotor.

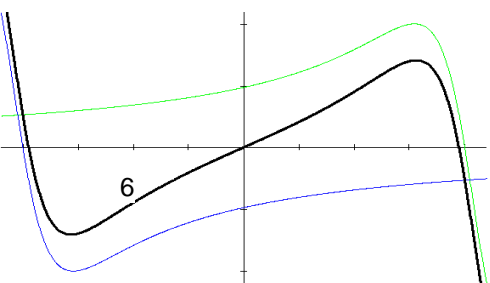
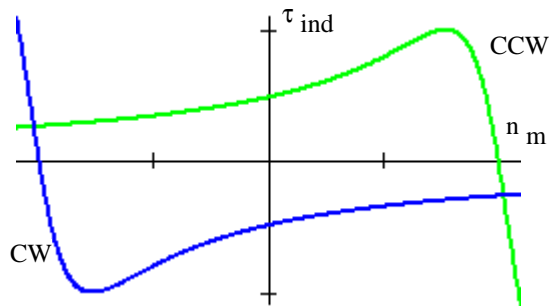

6 Motor will spin equally well in reverse, if you can just get it started that way.

Notice 6 important Things

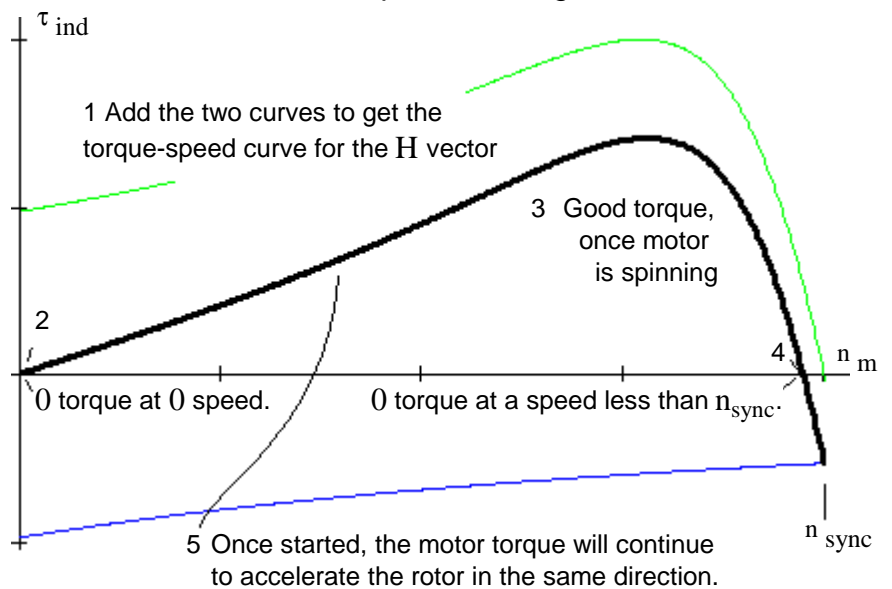

Think back to the first lab. Isn't that exactly what we saw in that lab?

So, how can we get this motor started?

Adding a second winding might help, but only if the timing (phase) of $i(t)$ and $i_2(t)$ are not the same. If the phase of $i(t)$ and $i_2(t)$ are the same, then there is no net field rotation. But, if $i_2(t)$ can be delayed a little from $i(t)$, then there would be some net field rotation in the counter-clockwise (CCW) direction. Alternatively, if $i_2(t)$ could lead $i(t)$, then there would be some net field rotation in the clockwise (CW) direction.

Unless you want to manually start the motor...

The motor NEEDS a second winding to get started, AND the phase of the two currents NEED to be different in order to get some net rotating magnetic field. No net rotating field -- means no starting torque.

Each winding can be modeled in the same way as a single phase of a 3-phase winding.

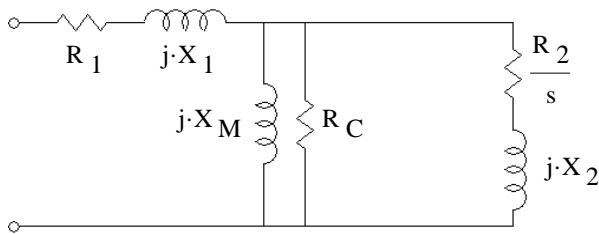

Sometimes the windings may be shown as something that looks like a single inductor, but it MUST have both resistance AND inductance.

Capacitor-Run Motor

A capacitor is hooked up in series with one winding of the motor.

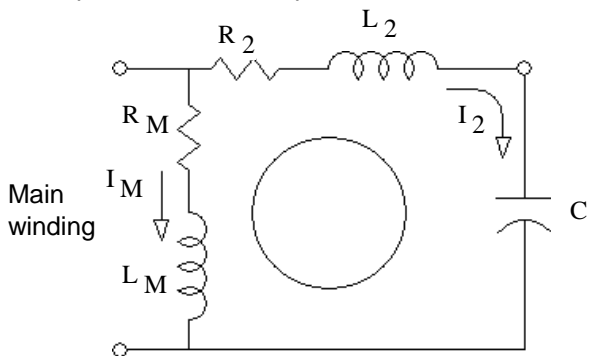

Ideally, choose a capacitor so that the current through the second winding (I_2) leads the current through the main winding (I_M) by 90° . Unfortunately, that will only be possible at one motor speed (or slip).

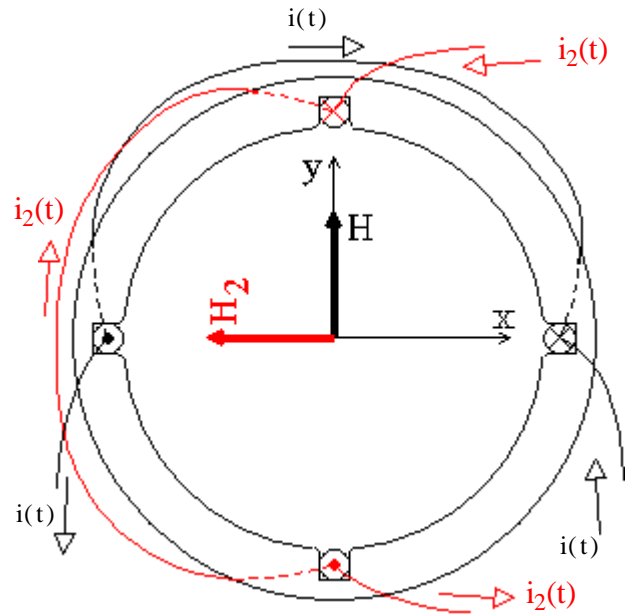

But are often shown as a single resistor and inductor.

The values of the resistor and inductor would only be valid at one value of slip (s).

The two windings may also be shown like this, to indicate that they are placed at a 90° angle to one another with respect to the rotor.

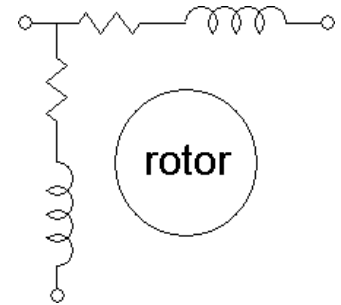

(Note: the actual angle would be less if it's not a 2-pole motor)

A better, but more complex and expensive system.

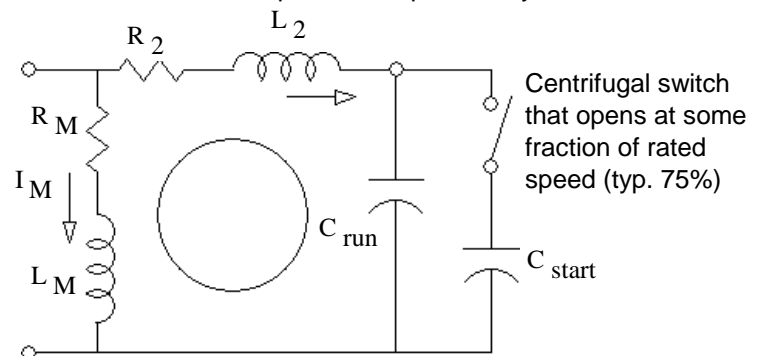

Now choose C_{run} to be ideal at normal operation and $C_{run} + C_{start}$ to be ideal at startup.

Capacitor-Start Motor

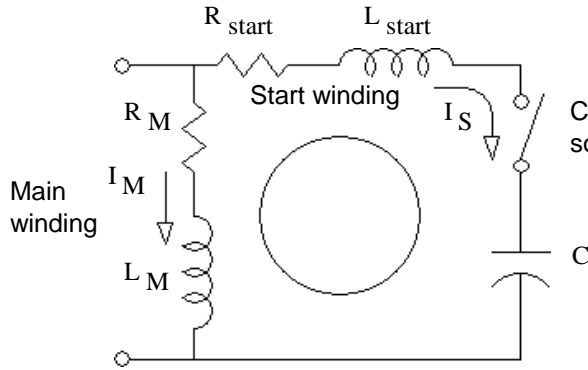

Centrifugal switch that opens at some fraction of rated speed (typ. 75%)

Ideally, choose a capacitor so that the current through the second winding (I_S) leads the current through the main winding (I_M) by 90° at startup ($s = 1$).

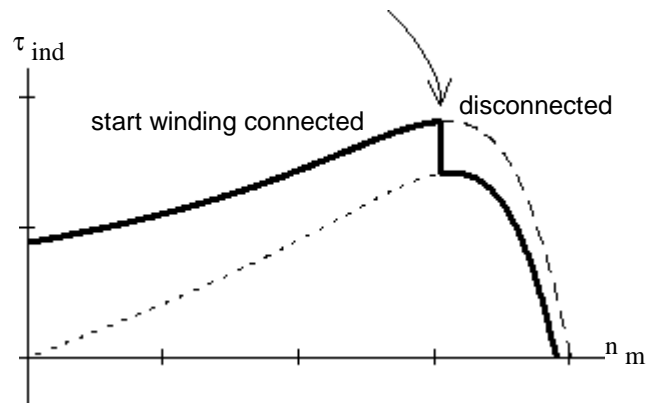

Capacitor Calculation For a specific slip

$$Z_M = R_M + j \cdot \omega L_M$$

$$I_M = \frac{V_T}{Z_M}$$

V_T is the terminal voltage

$$Z_S = R_S + j \cdot \omega L_S$$

$$I_S = \frac{V_T}{Z_S}$$

$$\phi = \angle I_{SC} - \angle I_M = \arg(I_{SC}) - \arg(I_M)$$

$$Z_S + Z_C = R_S + j \cdot \left(\omega L_S - \frac{1}{\omega C} \right)$$

$$I_{SC} = \frac{V_T}{Z_S + Z_C}$$

$$= \arg(Z_M) - \arg(Z_S + Z_C)$$

$$= \text{atan} \left(\frac{\omega L_M}{R_M} \right) - \text{atan} \left[\frac{\omega L_S - \frac{1}{\omega C}}{R_S} \right]$$

Where ϕ is the angle difference between the currents (or impedances).

Motor Starting Torque

Proportional to the current magnitudes and the sine of the phase angle difference between the winding currents.

$$(I_M \cdot I_S \cdot \sin(\phi))$$

Split-Phase Motor

The run winding has a large inductance and little resistance.

The start winding has little inductance and lots of resistance.

Cheap, but can only get about 30° of phase difference between currents

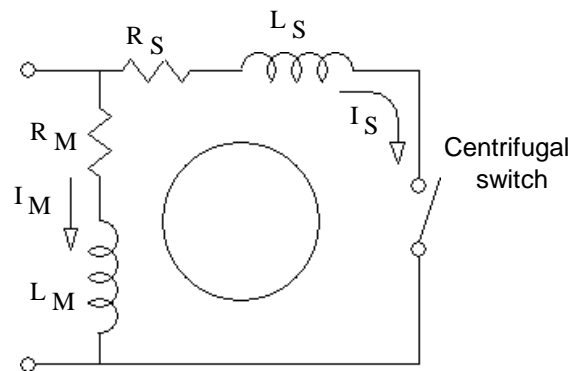

Start Direction: Reverse the leads to either of the windings to get the motor to start in the opposite direction.

ECE 3600 Single-Phase Induction Motor Examples

A.Stolp
11/18/19
rev

Ex. 1 From Fin F11. A Single-phase, 1/3-hp, 120-V split-phase motor draws 5 A in its main winding, and 3 A in its start winding when it is first switched on. The two currents lag the supply voltage by 40° and 15° respectively.

a) Find the initial start-up current (magnitude) and power.

$$\omega := 377 \frac{\text{rad}}{\text{sec}}$$

$$\mathbf{I}_{\mathbf{L}} := 5 \cdot \text{A} \cdot e^{-j \cdot 40 \cdot \text{deg}} + 3 \cdot \text{A} \cdot e^{-j \cdot 15 \cdot \text{deg}} \quad |\mathbf{I}_{\mathbf{L}}| = 7.822 \cdot \text{A} \quad \arg(\mathbf{I}_{\mathbf{L}}) = -30.672 \cdot \text{deg}$$

$$P_{\text{start}} := 120 \cdot \text{V} \cdot |\mathbf{I}_{\mathbf{L}}| \cdot \cos(\arg(\mathbf{I}_{\mathbf{L}})) \quad P_{\text{start}} = 807.36 \cdot \text{W}$$

b) To improve this motor, you want to add a capacitor in series with the start winding so that currents will be 90° out of phase with each other. Find the value of the required capacitor.

The original: $\mathbf{Z}_{\text{start}} := \frac{120 \cdot \text{V}}{3 \cdot \text{A} \cdot e^{-j \cdot 15 \cdot \text{deg}}} \quad \mathbf{Z}_{\text{start}} = 38.637 + 10.353j \cdot \Omega$

The start winding current should now lead the voltage by 50°.

$$X_{\text{start}} + X_{\text{C}} = -38.637 \cdot \Omega \cdot \tan(50 \cdot \text{deg}) = -46.046 \cdot \Omega$$

$$X_{\text{C}} := -46.046 \cdot \Omega - 10.353 \cdot \Omega \quad X_{\text{C}} = -56.399 \cdot \Omega = -\frac{1}{\omega \cdot \text{C}} \quad \text{C} := \frac{1}{-X_{\text{C}} \cdot \omega} \quad \text{C} = 47 \cdot \mu\text{F}$$

c) The new start winding current is about 2 A. The motor starting torque is proportional to the sine of the angle between the winding currents. It is also proportional to the magnitudes of the currents. How much bigger is the starting torque with the additional capacitor?

$$\frac{(2 \cdot \text{A}) \cdot (5 \cdot \text{A}) \cdot \sin(90 \cdot \text{deg})}{(3 \cdot \text{A}) \cdot (5 \cdot \text{A}) \cdot \sin(40 \cdot \text{deg} - 15 \cdot \text{deg})} = 1.577$$

Ex. 2 From Fin F12. A 1/4-hp, 120-V, 60-Hz, single-phase, capacitor-run, induction motor has two identical windings set 90° apart in the motor housing. Each winding draws 3 A at 30° lag when the rotor is locked and 1.5 A at 40° lag when the motor is running at its rated speed.

a) Find the ideal capacitor to place in series with one of the windings at startup.

Note: the ideal capacitor would create the ideal phase difference between the winding currents.

$$\mathbf{Z}_{\text{start}} := \frac{120 \cdot \text{V}}{3 \cdot \text{A} \cdot e^{-j \cdot 30 \cdot \text{deg}}} \quad \mathbf{Z}_{\text{start}} = 34.641 + 20j \cdot \Omega$$

$$X_{\text{start}} + X_{\text{C}} = -34.641 \cdot \Omega \cdot \tan(60 \cdot \text{deg}) = -60 \cdot \Omega$$

$$X_{\text{C}} := -60 \cdot \Omega - 20 \cdot \Omega \quad X_{\text{C}} = -80 \cdot \Omega = -\frac{1}{\omega \cdot \text{C}} \quad \text{C} := \frac{1}{-X_{\text{C}} \cdot \omega} \quad \text{C} = 33.2 \cdot \mu\text{F}$$

b) Find the ideal capacitor to place in series with one of the windings at rated speed.

$$\mathbf{Z}_{\text{run}} := \frac{120 \cdot \text{V}}{1.5 \cdot \text{A} \cdot e^{-j \cdot 40 \cdot \text{deg}}} \quad \mathbf{Z}_{\text{run}} = 61.284 + 51.423j \cdot \Omega$$

$$X_{\text{run}} + X_{\text{C}} = -61.284 \cdot \Omega \cdot \tan(50 \cdot \text{deg}) = -73.035 \cdot \Omega$$

$$X_{\text{C}} := -73.035 \cdot \Omega - 51.423 \cdot \Omega \quad X_{\text{C}} = -124.458 \cdot \Omega = -\frac{1}{\omega \cdot \text{C}} \quad \text{C} := \frac{1}{-X_{\text{C}} \cdot \omega} \quad \text{C} = 21.3 \cdot \mu\text{F}$$

c) Find a compromise capacitor to place in series with one of the windings. Choose this capacitor to make the current magnitude in the two windings exactly the same at rated speed. (Don't worry about the phase angles.)

$$X_{\text{C}} := -2 \cdot 51.423 \cdot \Omega \quad X_{\text{C}} = -102.846 \cdot \Omega = -\frac{1}{\omega \cdot \text{C}} \quad \text{C} := \frac{1}{-X_{\text{C}} \cdot \omega} \quad \text{C} = 25.8 \cdot \mu\text{F}$$

d) Find the input power at rated speed with the compromise capacitor in place.

$$\mathbf{I}_{\mathbf{L}} := 1.5 \cdot \text{A} \cdot e^{-j \cdot 40 \cdot \text{deg}} + 1.5 \cdot \text{A} \cdot e^{j \cdot 40 \cdot \text{deg}} \quad |\mathbf{I}_{\mathbf{L}}| = 2.298 \cdot \text{A} \quad \arg(\mathbf{I}_{\mathbf{L}}) = 0 \cdot \text{deg}$$

$$P_{\text{start}} := 120 \cdot \text{V} \cdot |\mathbf{I}_{\mathbf{L}}| \cdot \cos(\arg(\mathbf{I}_{\mathbf{L}})) \quad P_{\text{start}} = 275.8 \cdot \text{W}$$