

Answer the following questions in your textbook, p.348.

7-11. Why is it necessary to reduce the voltage applied to an induction motor as electrical frequency is reduced?

7-12. Why is terminal voltage speed control limited in operating range?

7-13. What are starting code letters? What do they say about the starting current of an induction motor?

7-14. What information is learned in a locked-rotor test?

7-15. What information is learned in a no-load test?

Solve the following problems in your textbook.

1. 7-1. A DC test is performed on a 460-V, Δ -connected, 100-hp induction motor. If $V_{DC} = 21V$ and $I_{DC} = 72A$, what is the stator resistance R_1 ? Why is this so?

Hint: Think about a single DC source hooked to a Δ connection.

2. 7-18. A 208-V, six-pole, Y-connected, 25-hp, design class B induction motor is tested in the laboratory, with the following results:

No load: 208 V, 22.0A, 1200 W, 60 Hz
Locked rotor: 24.6 V, 64.5 A, 2200W, 15 Hz
DC: 13.5 V, 64A neutral is not available

Find the equivalent circuit of this motor,
~~and plot its torque-speed characteristic curve.~~

3. 7-24. Answer the following questions about a 460-V, Δ -connected, two-pole, 100-hp, 60-Hz, starting code letter F induction motor:

a) What is the maximum current that this machine's controller must be designed to handle?

b) If the controller is designed to switch the stator windings from a Δ -connection to a Y-connection during starting, what is the maximum starting current that the controller must be designed to handle? (This means that the motor will start Y-connected and later switch to the normal Δ .)

Voltage will be reduced by $\sqrt{3}$

c) If a 1.25:1 step-down autotransformer starter is used during starting. what is the maximum starting current that it must be designed to handle? (This is instead of the Y-connected start)

The following problems are not from your textbook

4. How can you reverse the direction of rotation of a capacitor-start motor? That is, reverse the direction it starts.

- a) Reverse the leads to the capacitor.
- b) Reverse the positions of the capacitor and the start (second) winding.
- c) Reverse the leads to the main winding.
- d) Reverse the leads to the start winding.
- e) Reverse the leads to both the main and the start windings.

Will this also work for a capacitor-run motor?

5. At the instant of starting a 1/4-hp 120-V split-phase motor draws 5 A in its starting winding, and 8 A in its main winding. The two currents lag the supply voltage by 20° and 45° , respectively. At startup, determine:

a) the line current and power factor, and

b) the in-phase components of the currents with the supply voltage.

6. A capacitor is added in series with the starting winding of the motor in the previous problem. The starting current in the start winding now leads the voltage by 40° . The main winding remains as is.
 a) With this added capacitor, determine at the instant of starting the line current and the power factor.

b) Compare the line current to that calculated in problem 4

c) The motor starting torque is proportional to the sine of the angle between the winding currents. It is also proportional to the magnitudes of the currents. How much bigger is the starting torque with the additional capacitor?

7. A single-phase motor impedances are as shown at 60 Hz:

Find the capacitor size that will produce the phase angle $\alpha = 90^\circ$.

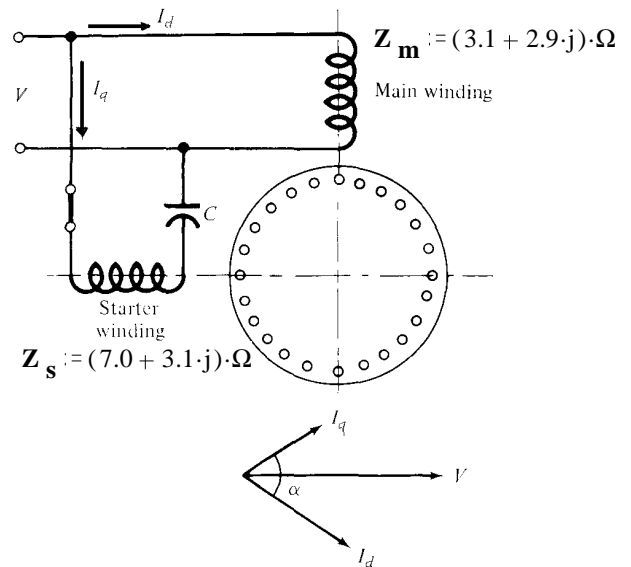

8. A 1/3-hp, 120-V, 60-Hz, single-phase, capacitor-run, single-phase induction motor has two identical windings **Ind3 p5** set 90° apart in the motor housing. Each winding draws 6.8 A at 20° lag when the rotor is locked and 2 A at 40° lag when the motor is running at its rated speed. This is with no added capacitors, so the motor would have to be started by hand.
- a) Find the ideal capacitor to place in series with one of the windings at **startup**.
 Note: the ideal capacitor would create the ideal phase difference between the winding currents.

- b) Find a different capacitor to replace the capacitor of part a). Choose this capacitor to make the current magnitude in the two windings exactly the same at rated speed. (Don't worry about the phase angles.)

- c) The ideal capacitor to to get 90° phase difference at rated speed is $28.4\mu\text{F}$. What would be a good compromise between the answer of part b) and $28.4\mu\text{F}$? Choose a nice round number.

- d) If the motor had a centrifugal switch which opens at half the rated speed, devise a design to achieve approximate conditions of parts a) and c). Find all capacitor values needed. Choose a nice round numbers. (Remember, cap values add when in parallel.)

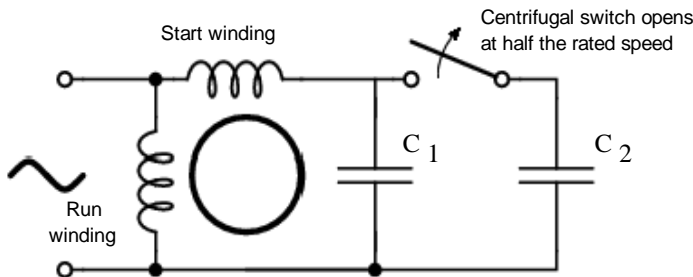

Answers 1. $0.437\cdot\Omega$

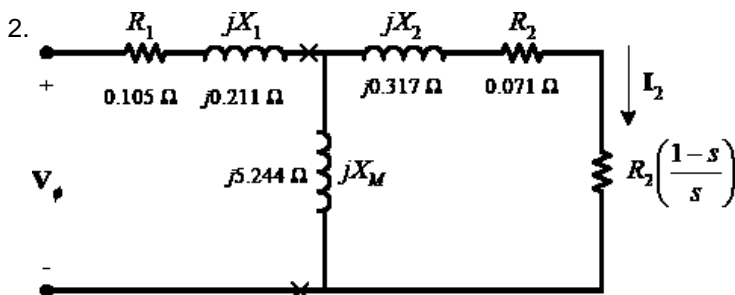

3. a) 703-A b) 234-A c) 450-A 4. c & d yes
 5. a) 12.708-A 0.815 lagging b) 4.70-A 5.66-A
 6. a) 9.29-A 0.945 lagging
 b) Almost 27% less c) 1.92 times bigger
 7. $251\cdot\mu\text{F}$ 8. a) $51.41\cdot\mu\text{F}$ b) $34.4\cdot\mu\text{F}$ c) $30\cdot\mu\text{F}$
 d) $C_1 := 30\cdot\mu\text{F}$ $C_2 := 20\cdot\mu\text{F}$