

## Per-Unit 2

Name \_\_\_\_\_ ECE 3600 homework 11

d

1. A one-line diagram of a 3 $\phi$  system is shown below. Manufacturer's information is shown for the generator and each transformer.

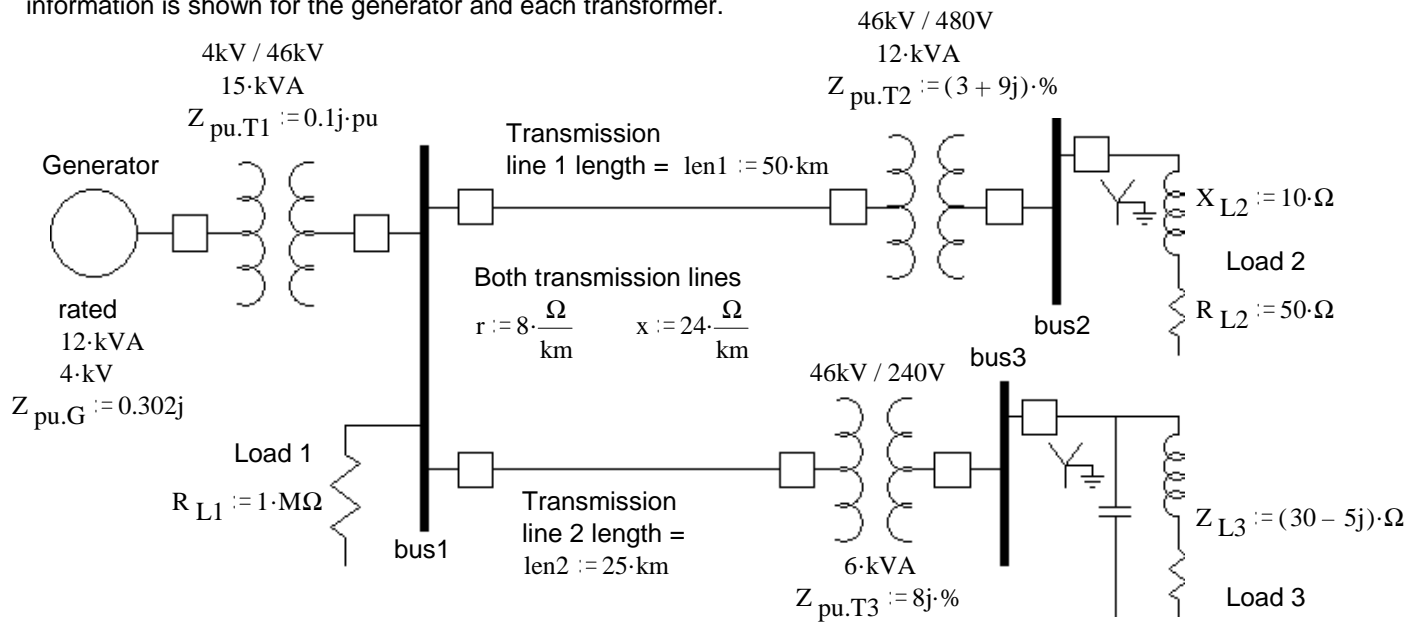

a) Choose an  $S_{base}$  to minimize the per-unit base conversions. Then choose regions and a  $V_{base}$  for each region.

b) Find  $I_{base}$  and  $Z_{base}$  in each of the regions.

c) Make the necessary per-unit  $S_{\text{base}}$  conversions.

d) Find the impedances of the two transmission lines and convert to pu.

e) Draw the per-phase diagram, showing all the per-unit numbers found or given so far.

ALL calculations made to this point **ONLY need to be made ONCE**  
for this system and  $S_{\text{base}}$  !!

f) Find the pu values of the 3 loads and add that information to the per-phase diagram on the previous page.

g) The line voltage at bus1 is measured and found to be  $V_{\text{bus1}} := 46.00\text{-kV}$  Assume the phase angle is  $0^\circ$ .

Find all 3 load line-current magnitudes and the magnitude of the generator line-current. Please remember that you can't add magnitudes, so may need some complex values.

h) Find the power delivered to Load 2, both in pu and in kW.

i) Find the line voltage at Load 2 (magnitude).

j) Find the line voltage at the generator (magnitude).

k) The line voltage at the generator drops by 10%, what is it now?

l) Find the magnitude of Load-3 line current and repeat parts h) and i) for this new generator voltage.

Note: It may be helpful to realize that if one voltage in the system drops by 10%, so do all the rest, and so do all the currents. Drop by 10% means multiply by 0.9. All powers drop too, but use  $(0.9)^2$  as the factor.

**Answers**

1. a) 12·kVA 4·kV 46·kV etc

b) 1.732·A 1.333·kΩ 0.151·A 176.3·kΩ etc

c) through j) see drawing (mix of pu values and real values, pay attention to units)

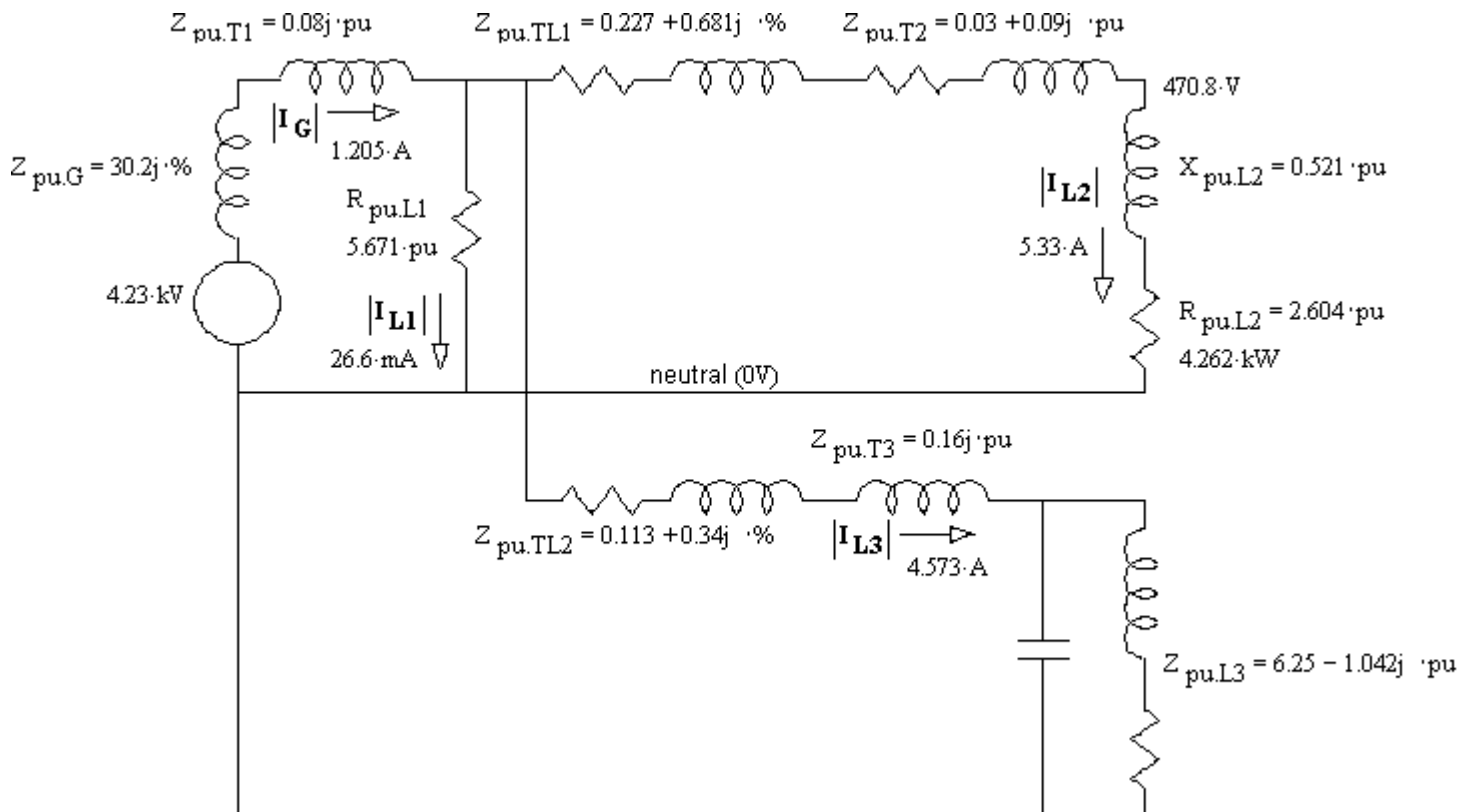

k) 3.807·kV

l) 4.1·A 3.452·kW 423.7·V