

Write Legibly! Closed book, Closed notes, Calculator OK.

1. What is the term used for devices which automatically try to restore power shortly after a trip?
2. Why are manually operated disconnect switches placed in substations?
3. What does a GCFI device detect to trip?
4. a) Large breakers come in what two types?
b) Which type is the newer technology?
5. What two devices provide critical information to the relays?
6. What is the relationship between relays and breakers.
7. The time-delay curve of an over-current relay is shown.
 - a) How long will it take to trip the breaker if the current is 3 times the pickup current?
 - b) How long will it take to trip the breaker if the current is 10 times the pickup current?
 - c) What is the quickest this relay will trip the breaker?
8. What type of relay can detect a relatively small unwanted current to ground?
9. What type of relay requires communications between substations, and what is its purpose?
10. How does one set up the relays so as to minimize the impact of a fault on customers?
11. What type of power is used for the relays and breakers?
12. What conditions must be met before breakers are reset?

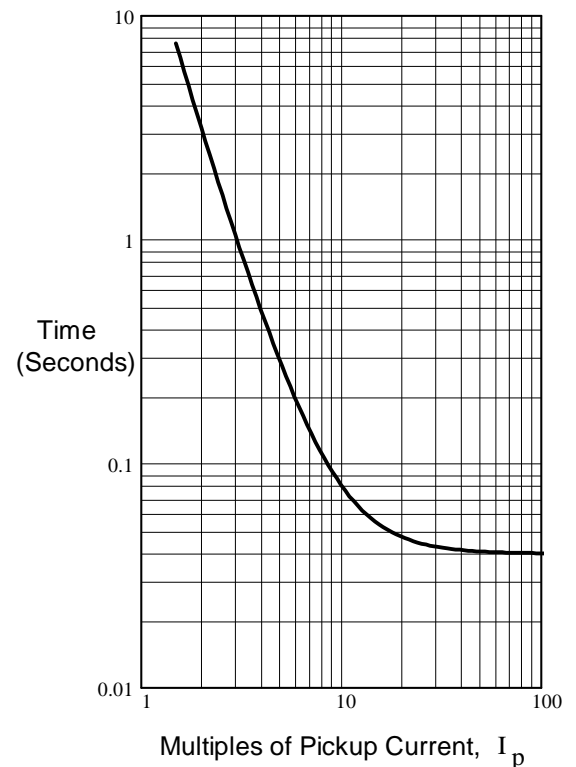

13. a) List at least 3 different synchronous motor speeds in the US, in rpm.

b) How are typical induction motor rated speeds related to the synchronous motor speeds?

c) When the power is first turned on to an induction motor, what is the slip? $s = ?$

d) When an induction motor is operated at its rated output, what is a typical slip? $s = ?$

14. An induction motor is operated with a variable-frequency drive.

a.1) How is the motor operated at slower-than-normal speeds?

a.2) Is there something else which must also be reduced? If yes, what and why?

b) How is the motor operated at higher-than-normal speeds?

15. a) The torque-speed curve shown at right is typical of what type of motor? (More than one answer is possible).

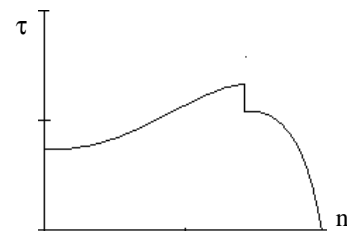

b) These motors have a special component not found in the other motors we studied. What is it?

16. a) DC motors are usually classified by the way the field is created or wired. What are the 4 types of DC motors.

- 1.
- 2.
- 3.
- 4.

b) One of these types is also commonly used with AC power, which one?

ECE 3600 Final Part 2 Spring 2023

Fin
S23

1. (20 pts) A single-phase, 60-Hz, 240-V source is connected to two loads. The source provides 2500W and 11A. In order to find the following, you may have to make some assumptions. If you do, be sure to clearly state your assumption in such a way that I can tell that you know what the other assumption might be.
- a) Load 1 consumes 1500W at a power factor of 0.8. Find the complex power consumed by load 2.

Don't forget to indicate your assumptions, if you made any.

b) Load 2 can be modeled as 2 parts. Draw a model and find the values of the parts.

c) An additional component could be added in parallel to the loads to completely correct the power factor of both. Find the type and value of the component.

2. (20 pts) A 3-phase system delivers 480-V (line voltage) , 60-Hz 3-phase power of 15 kW to a load with a 75% lagging power factor. Each line has a resistance of 0.47Ω . ("delivers" means those are the values at the load.)

a) Three Y-connected sources supply the power. What voltage do they each supply (magnitude)?

b) Find the total power lost in the lines and the overall efficiency of the system.

c) Three capacitors are Y-connected at the load to correct the power factor. Find the capacitor value(s).

d) The source voltage is adjusted so that the load power remains 15 kW.
What is the new efficiency of the system with the capacitors of part c).

3. (18 pts) The torque-speed characteristics of a DC motor are shown below. The top line is the induced torque. The lower line is torque lost to friction.

Notes: I intend for you to solve this graphically, so answers won't be perfect. Rulers are available from Arn. Add extra lines and show operating points. You may solve this algebraically, if you wish.

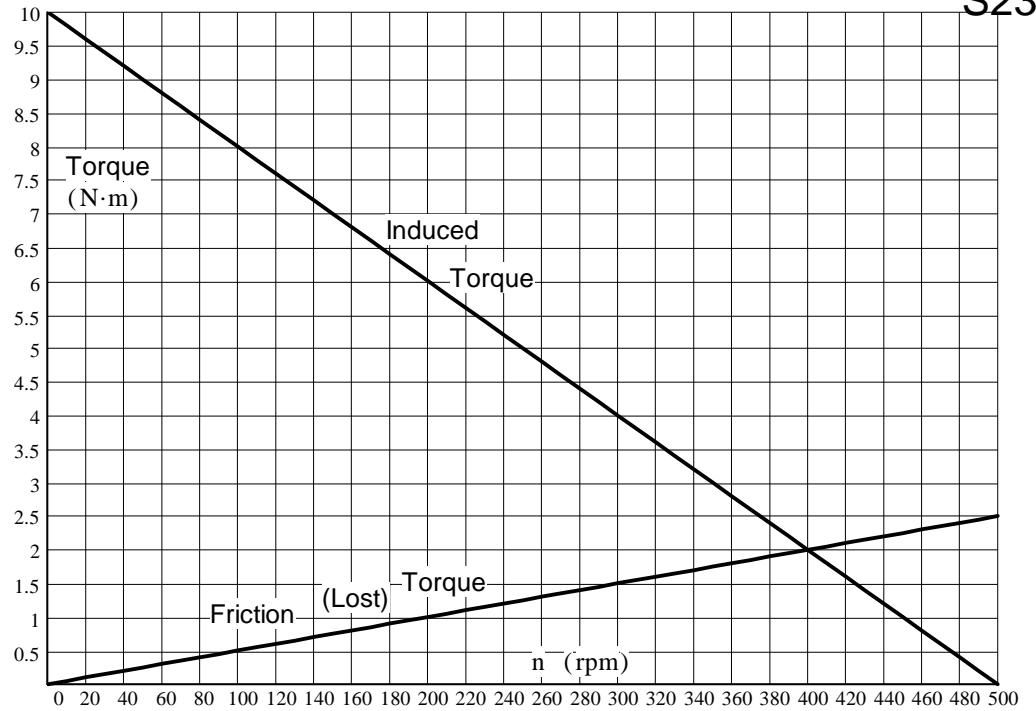

a) The curve below shows a load curve which is coupled to this motor. Graphically determine motor and load speed.

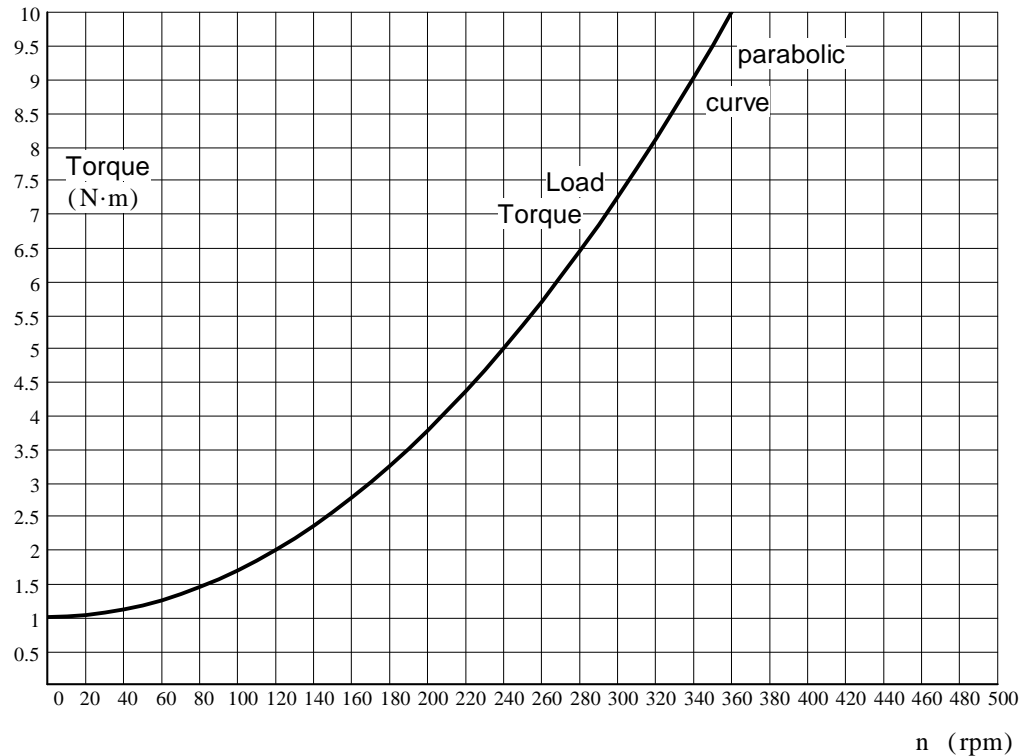

b) The terminal voltage of the motor is reduced by half. Graphically determine the new motor and load speed.

4. (32 pts) A 230 kV (nominal) transmission line has the following length and line parameters. S := siemens

$$\text{len} := 180 \cdot \text{km} \quad r := 0.20 \cdot \frac{\Omega}{\text{km}} \quad x := 0.60 \cdot \frac{\Omega}{\text{km}} \quad g := 0 \cdot \frac{\text{S}}{\text{km}} \quad y := 4 \cdot 10^{-6} \cdot \frac{\text{S}}{\text{km}}$$

Fin
S23

- a) Choose the most appropriate model for this transmission line and draw it, including the impedance and/or admittance value(s). Add a 3 ϕ load at the receiving end of the transmission line.

The line current to the **load**, \mathbf{I}_R (not \mathbf{I}_{Line}) is $250+100j$ A.

The magnitude of one phase of the Y-connected load impedance is 510Ω .

- b) Find the load phase voltage, \mathbf{V}_R , magnitude. Assume its phase is 0° (relative to the current given above).

$$\mathbf{V}_R = ?$$

- c) Find the line current in your model, \mathbf{I}_{Line} (not \mathbf{I}_S) in a complex-number form. $\mathbf{I}_{\text{Line}} = ?$

4. Continued d) What is the line voltage at the source (magnitude)?

Fin
S23

e) What is the "power angle" (δ)?

f) Find the complex impedance of one phase of the load, assuming Y-connected.

g) Find the power consumed by the entire load.

h) Find the power factor of the load.

i) Consider the source voltage and the load voltage of this transmission line. Is there anything weird about them? If yes, say what and tell me the cause of the of this weirdness.

5. (24 pts) Consider the small power system shown below. values shown are per-unit.

Note: % = 0.01 pu

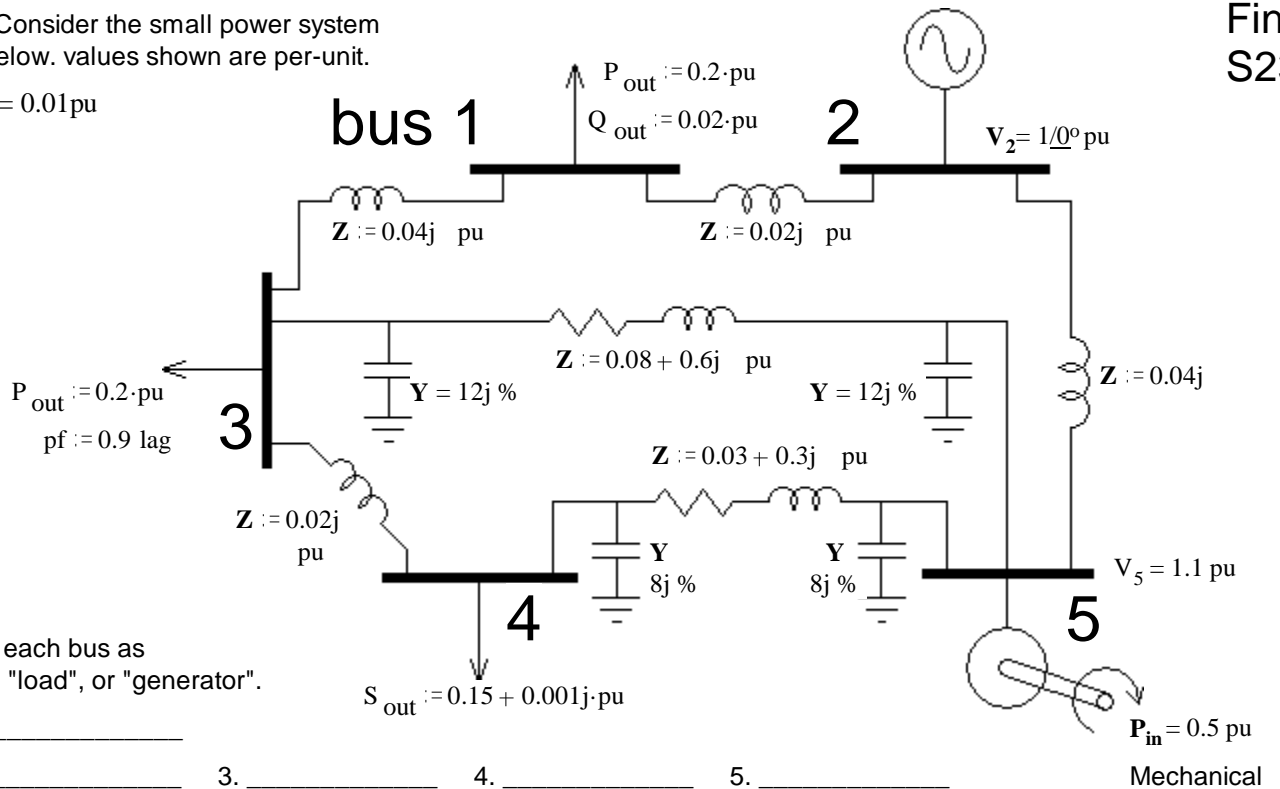

a) Identify each bus as "slack", "load", or "generator".

bus 1. _____
 2. _____ 3. _____ 4. _____ 5. _____

b) Show V_1 , V_3 , V_4 and V_5 on the drawing (as letters, not values).

c) Show I_1 , I_2 , I_3 , I_4 and I_5 on the drawing and draw arrows to indicate the direction of each.

d) What is the 5x5 matrix shown below called? _____

$$\begin{bmatrix} I_1 \\ I_2 \\ I_3 \\ I_4 \\ I_5 \end{bmatrix} = \begin{bmatrix} _ & _ & _ & _ & _ \\ _ & _ & _ & _ & _ \\ _ & _ & \mathbf{A} & _ & \mathbf{B} \\ _ & _ & _ & _ & _ \\ _ & _ & _ & _ & _ \end{bmatrix} \cdot \begin{bmatrix} V_1 \\ V_2 \\ V_3 \\ V_4 \\ V_5 \end{bmatrix}$$

e) A number of the elements of the matrix are zero (0). Fill in all the zero elements.

f) Find elements **A** and **B** in the matrix above. I want numerical answers accurate to ± 0.001 .

6. (24 pts) One phase of a balanced 3-phase system is shown here. Line A, and only line A, opens at the point shown.

a) Draw the circuit you would have to analyze to find the fault voltage across the open in line A (V_A). Identify the parts and include the component voltages and/or currents at the fault.

b) Set up a mathematical expression (or expressions) to find the fault voltage. If you use thevenin values, make sure you show how to get them from items in the drawing. (Don't forget j & that the fault voltage is NOT V_{A1})

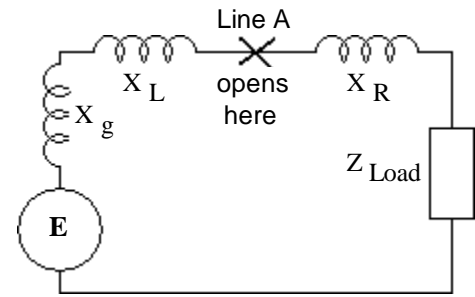

Fin
S23

Answers

1. Reclosure 2. So that lineman working on the equipment can visually confirm that items are de-energized.
3. A difference between the outgoing and returning currents 4. a) Oil and gas b) gas (SF₆) 5. CTs and VTs
6. Relays control the breakers 7. a) 1-sec b) 0.08-sec c) 0.04-sec 8. Differential
9. Pilot detects currents from transmission lines to ground 10. Set relays so that breakers closest to the fault trip first
11. DC 12. Safety protocols and possibly synchronization 13. a) $\frac{3600\text{-rpm}}{\text{any_integer}}$ b) They are a little less (about 5% less) c) 1 d) 0.05 = 5%
14. a.1) The frequency is less than 60Hz.
a.2) The voltage must be reduced to prevent saturation of the core. b) The frequency is greater than 60Hz.
15. a) Split-phase or single-phase induction motor b) A centrifugal switch
16. a) 1. Separately excited 2. Series excited 3. Shunt excited 4. Permanent magnet b) Series excited
1. a) $1 - 0.277\text{-}j$ kVA Assuming I_S lags V_S & the L1 pf is lagging b) Parallel $57.6\text{-}\Omega$ & $12.74\text{-}\mu\text{F}$ c) Capacitor
Series $53.5\text{-}\Omega$ & $179.2\text{-}\mu\text{F}$ $39.1\text{-}\mu\text{F}$

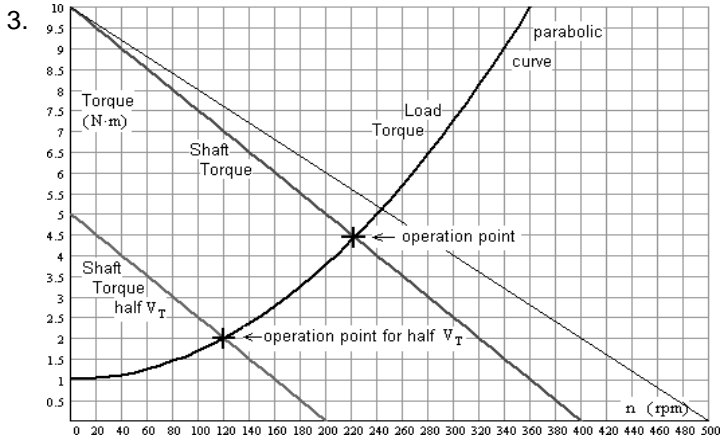

3. a) 222.5-rpm b) 120-rpm
5. a) load slack load load gen

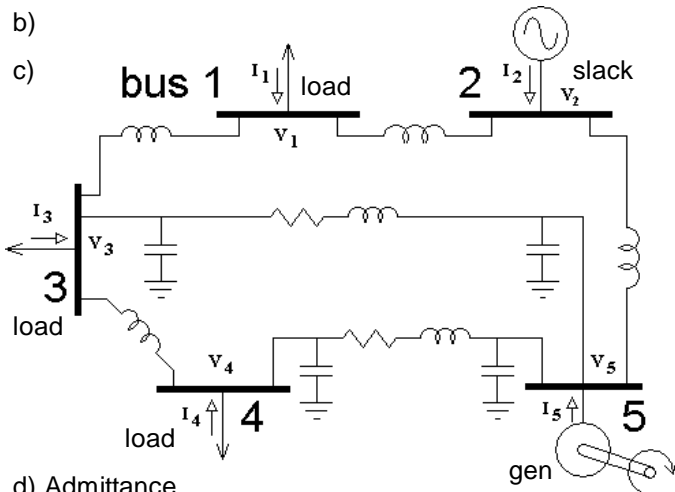

d) Admittance

$$e) \begin{bmatrix} _ & _ & _ & 0 & 0 \\ _ & _ & 0 & 0 & _ \\ _ & 0 & A & _ & B \\ 0 & 0 & _ & _ & _ \\ 0 & _ & _ & _ & _ \end{bmatrix}$$

- f) $0.218 - 76.518\text{-}j = 76.52 / -89.84^\circ$ pu
 $-0.218 + 1.638\text{-}j = 1.652 / 97.59^\circ$ pu

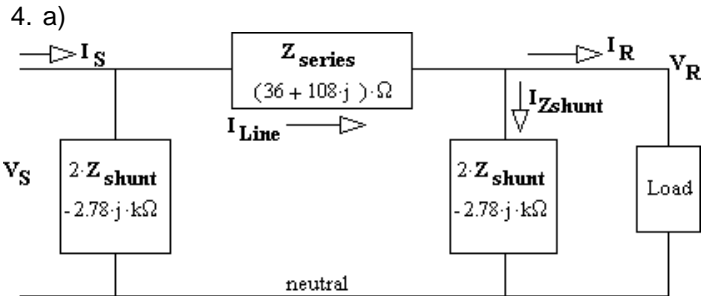

4. a) b) 137.3-kV c) $250 + 149.44\text{-}j$ A d) 232.4-kV
e) 13.97-deg f) $510\text{-}\Omega - 21.8\text{-}deg$ g) 103-MW h) 0.928
i) The source voltage is less than the load voltage. This is because the load is capacitive and the line is inductive.

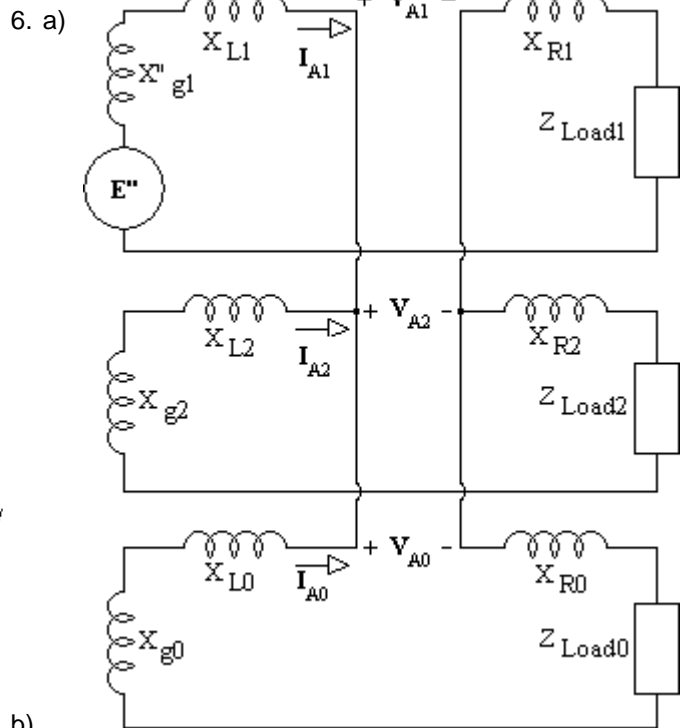

b)

$$Z_2 = (X_{g2} + X_{L2})\text{-}j + X_{R2}\text{-}j + R_{Load2}$$

$$Z_0 = (X_{g0} + X_{L0})\text{-}j + X_{R0}\text{-}j + R_{Load0}$$

$$Z_{20} = \frac{1}{\frac{1}{Z_2} + \frac{1}{Z_0}}$$

$$V_A = 3 \cdot V_{A1} = 3 \cdot E'' \cdot \frac{Z_{20}}{(X''_{g1} + X_{L1})\text{-}j + Z_{20} + X_{R1}\text{-}j + R_{Load1}}$$