

# ECE 3600 Final, given: Fall 2020

Closed Book, Closed notes except for those given in class for Exam 1, 2, and final, Calculators OK, Show all work to receive credit. Circle answers, show units, and round off reasonably

Write Legibly! If I can't read what you've written or you answer is ambiguous, I'll assume you don't know.

1. (30 pts) R, L, & C together are the load (in dotted box). The power used by the load is  $P_{\text{Load}} := 726 \text{ W}$  Find:

- a) The magnitude of the resistor current.  
 $|I_R| = ?$

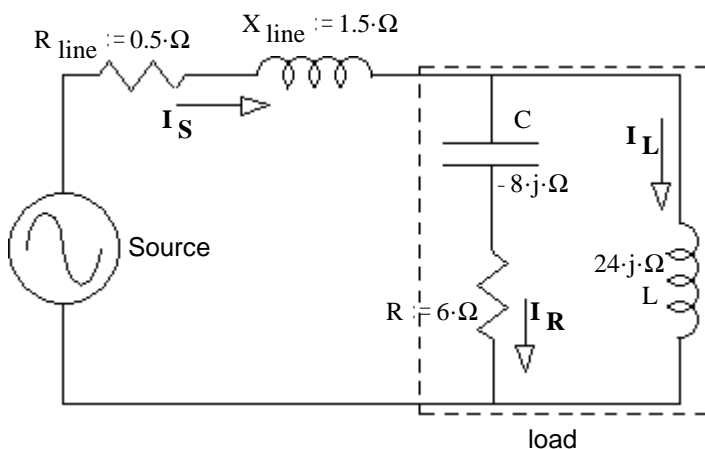

- b) The voltage at the load (magnitude).  $V_{\text{Load}} = ?$

- c) The reactive power used by the load.  $Q = ?$

- d) The apparent power of the load.  $|S| = S = ?$

- e) The power factor of the load.  $\text{pf} = ?$

- f) This power factor is: i) leading ii) lagging (circle one)

- g) The magnitudes of the other currents.  $|I_L| = ?$   $|I_S| = ?$

- h) The source voltage (magnitude).  $V_S = ?$

- i) Is there something weird about this voltage? If so, what?

- j) Why?

2. (34 pts) A one-line drawing of a 3-phase system is shown. Some 3-phase Ps and Qs are also shown. The 3-phase transformer is made of 3 individual single-phase transformers, each with a 5:1 turns ratio. Consider them to be ideal. They are hooked up Y - Y step-down so that the voltages on the left are 5x the voltages on the right. Remember that bus and line voltages are the same. a) Find the complex power consumed by load 1.

Hints: Work from load 2 back and if you don't use Ps and Qs to solve this problem it will be VERY HARD!

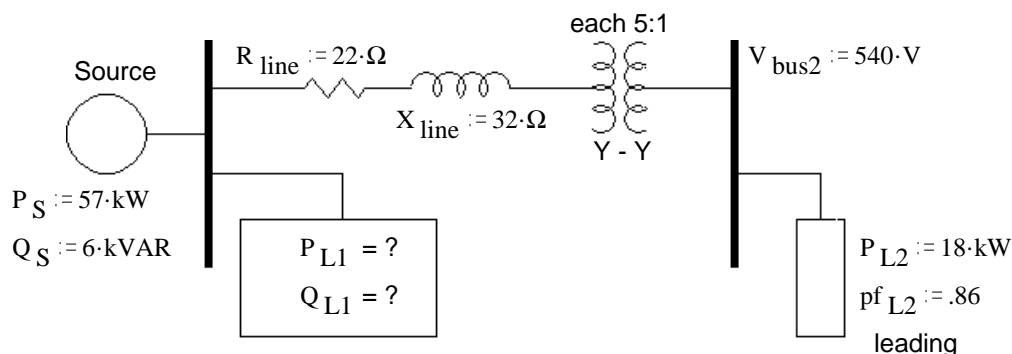

- b) What is the efficiency of this system?  $\eta = ?$

### Answers

1. a) 11·A    b) 110·V    c) -463.8·VAR    d) 861.5·VA    e) 0.843  
 f) Leading, capacitor dominates    g) 4.583·A    7.832·A    h) 107.6·V    i)  $V_S$  is less than  $V_{Load}$   
 j) Partial resonance between the inductance in the line and the capacitance of the load.  
 OR Because the Q of the line partially cancels the Q of the load
2. a)  $(37.68 + 14.76j) \cdot VA$     b) 97.7·%
3. a)  $0^\circ$     0·W    b) 30.38·Ω    c) 24.94·kVAR    d) 188.5·kW    e) 24.68·deg    f) -16.29·kVAR    g) 2407·V  
 h) The operator changes the field current to: 21.8·A    i) decreased
4. a) ii)    b) 3.158·Ω    c) 213.9·W    d) 203.6·W    e) 32.32·%    f) 0·%    g) 145·V    h) 1609·W    i) 1478·W
5. a) 1.273·Ω    0.118·V·sec    b)  $6.33 \cdot 10^{-4} \cdot N \cdot m \cdot sec$      $9.29 \cdot 10^{-2} \cdot N \cdot m$     c) A third set of measurements at a third  $V_T$ .
6. b) 236·A    -28.8·deg    c) 100·kV    14.35·deg  
 d) 173.3·kV    e) 14.35·deg    f) 306.7·Ω    34.9·deg

3. (34 pts) A 3-phase, synchronous generator is not electrically connected to anything. The prime mover is spinning the generator at 3600 rpm. The input torque is 30 Nm. When the field current is 10 A, DC, the terminal voltage is 1100 V. The field current is raised to 20 A, and the terminal voltage goes up to 2200 V. The generator is now Y-connected to a 3.6 kV, 60 Hz, bus. The line current is measured at 4 A. The input torque is still 30 Nm, just enough to overcome rotational losses.

a) What is the power angle and/or how much power is being generated?

b) Find the synchronous reactance.  $X_s = ?$       givens  $f := 60 \cdot \text{Hz}$        $\tau_{in} := 30 \cdot \text{N}\cdot\text{m}$        $V_L := 3.6 \cdot \text{kV}$

If you can't find  $X_s$ , or doubt your value, mark here \_\_\_\_\_ and use  $X_s = 30 \Omega$  for the rest of the problem. If it still doesn't seem like you have enough information to answer the following parts, Ask via text. I will answer questions for points.

c) Find the total reactive power generated.

d) The prime mover torque is increased to  $\tau_{in} := 530 \cdot \text{N}\cdot\text{m}$  Find the generated electrical power  $P = ?$

The prime mover torque is held at this value for the rest of the problem.

e) Find the power angle.  $\delta = ?$

3. continued f) Find the total reactive power generated.

g) The generator operator is told to produce 30 kVAR , no change in real power. Find the required  $E_A$ .

h) What does the operator change to get this new  $E_A$ , and to what new value.  
Hint: reread the initial problem statement.

i) Did the power angle change with the the previous change?  
If yes, say whether it increased or decreased.  
No calculation is required.

4. (35 pts) A separately excited dc motor is rated at 2-hp, 1000rpm, armature: 180 V 12A, field: 180 V 0.5A. Unless stated otherwise, assume rated voltages below.
- a) The motor is loaded with an unknown mechanical load. It spins at 1200rpm and the armature current is 3A. The unknown load is: i) 2 hp ii) Less than 2 hp iii) Greater than 2 hp iv) Can't tell from the given information
- b) Find  $R_A$  from the information given in a) and the ratings. Hint: See the final item of the DC motor notes
- ratings:  $V_T := 180 \cdot V$      $n_{fL} := 1000 \cdot \text{rpm}$      $I_{AfL} := 12 \cdot A$      $1 \cdot \text{hp} = 745.7 \cdot W$
- unknown load:     $n_2 := 1200 \cdot \text{rpm}$      $I_{A2} := 3 \cdot A$

If you can't find  $R_A$ , mark an X here \_\_\_\_\_ and use  $3\Omega$  for the rest of the problem.

- c) Find the rotational losses at when operated at full load.  $P_{rot} = ?$

- d) Find the unknown load power from part a). The rotational loss torque is proportional to the motor speed.

Hint: This also means that the rotational loss is proportional to  $n^2$ , like this:  $P_{rot2} = P_{rot1} \cdot \frac{n_2^2}{n_1^2}$

**This is the mechanical load for the rest of the problem. Actual power and torque may change if speed changes**

- e) Find the overall efficiency (includes power needed for the field) when operated at the load you just found.

$$I_F := 0.5 \cdot A$$

- f) If this seems off to you, remember that this is a small load and take this to the limit. That is, consider the no-load efficiency. What is the no-load efficiency? Hint: This is a "duh" question.

**The field voltage is reduced to 90V and field flux drops to half of its former value.**

**The armature is still at the rated voltage. The new speed is 2040rpm.**

- g) Find the new  $E_A$  Hint: it can't be greater than  $V_T$

4, continued h) Find the new  $P_{\text{conv}}$

i) If the load power were also proportional to  $n^2$ , just like the rotational loss, then  $P_{\text{conv}}$  would be proportional to  $n^2$ . Find the new  $P_{\text{conv}}$  using this assumption and compare it to that found above.

5. (20 pts) A permanent-magnet DC motor is coupled to a mechanical load. If it is hooked to a 6-V source, it draws 1A and spins at 40rad/sec. If it is hooked to a 20-V source, it draws 1.6A and spins at 152rad/sec.

a) Find  $R_A$  and  $K\phi$ . Hint: See the final item of the DC motor notes

Keep at least 4 significant digits for all your numbers. The results are very sensitive to roundoff errors.

$$V_{T1} := 6 \cdot V \quad I_{A1} := 1.0 \cdot A \quad \omega_1 := 40 \cdot \frac{\text{rad}}{\text{sec}} \quad V_{T2} := 20 \cdot V \quad I_{A2} := 1.6 \cdot A \quad \omega_2 := 152 \cdot \frac{\text{rad}}{\text{sec}}$$

b) If we assume that the mechanical load torque combined with the internal frictional torque of the motor is some constant torque plus some torque that is proportional to speed, then we could express the induced torque like this:

$$\tau_{\text{ind}} = B \cdot \omega + D \quad B \text{ and } D \text{ are constants and } \tau_{\text{ind}} = K\phi \cdot I_A$$

Find the constants B and D from the information given.

c) If you assumed  $\tau_{\text{ind}} = B \cdot \omega^2 + D \cdot \omega + E$  instead of  $\tau_{\text{ind}} = B \cdot \omega + D$

Is there something extra that you would need in order to find the third constant? If yes, what?

6. (27 pts) A 138 kV (nominal) transmission line is 220 km long and has the following line parameters.

$$\text{len} := 220 \cdot \text{km} \quad R := 0.1 \cdot \frac{\Omega}{\text{km}} \quad \omega L := 0.6 \cdot \frac{\Omega}{\text{km}} \quad G := 0 \cdot \frac{\text{S}}{\text{km}} \quad \omega C := 3.6 \cdot 10^{-6} \cdot \frac{\text{S}}{\text{km}} \quad \text{S} := \text{siemens}$$

a) Choose the most appropriate model for this transmission line and draw it, including the impedance and/or admittance value(s).

b) A source is connected to one end of the line and a load is connected to the other end. The line-to-line voltage at the load is 134 kV. Assume the load voltage phase is  $\angle 0^\circ$ . The power delivered to the 3-phase load is 48 MW at a power factor of 0.82 lagging. Find the line current  $\mathbf{I}_{\text{Line}}$  (not  $\mathbf{I}_S$ ) in complex-number form.

$$\mathbf{I}_{\text{Line}} = ?$$

c) Same load and conditions as part b). Find the source phase voltage,  $\mathbf{V}_S$ , magnitude and phase.  $\mathbf{V}_S = ?$

d) What is the line voltage at the source (magnitude)?

e) What is the "power angle" ( $\delta$ )?

f) Find the impedance of one phase of the load, assuming Y-connected.