

# ECE3600 Final given: Fall 16

(70 pts) Questions This part of the exam is **Closed book, Closed notes, No Calculator.**  
 Wrong answers may cost up to 3 times what a right answers is worth. Blanks cost the same as the right answer was worth.

1. Consider the single-phase system below. There are two sources, labeled S1 and S2 and two loads, labeled L1 and L2. All the variables shown or referred to in the questions are scalar or magnitudes of complex numbers. The same should be true of your answers.

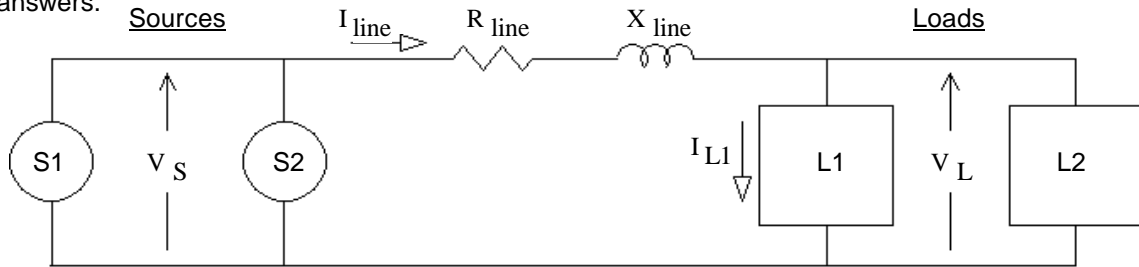

Example) Is there a simple relationship between all the real powers above? NO  YES   
 If yes, express that relationship in a mathematical way.

$$P_{S1} + P_{S2} = P_{Rline} + P_{L1} + P_{L2} \quad \text{OR} \quad P_{S1} + P_{S2} = I_{line}^2 \cdot R_{line} + P_{L1} + P_{L2} \quad (\text{Only one answer is necessary})$$

a) Is there a simple relationship between all the reactive powers above? NO YES  
 If yes, express that relationship in a mathematical way.

b) Is there a simple relationship between all the apparent powers above? NO YES  
 If yes, express that relationship in a mathematical way.

c) Is there a simple relationship between all the power factors above? NO YES  
 If yes, express that relationship in a mathematical way.

d) Express  $I_{line}$  in terms of source real and/or reactive powers and  $V_S$ . (Please remember that these variables are all scalar or magnitudes.)  $I_{line} =$

e) Express  $I_{line}$  in terms of load real and/or reactive powers and  $V_L$ .  $I_{line} =$

f) Express  $I_{L1}$  in terms of load real and/or reactive powers and  $V_L$ .  $I_{L1} =$

g) Express the efficiency in terms of real and/or reactive powers.  $\eta =$

2. Consider the balanced three-phase load shown. Except for the  $Z$ 's, all the variables shown or referred to in the questions are scalar or magnitudes of complex numbers. The same should be true of your answers. Where possible, express answers mathematically.

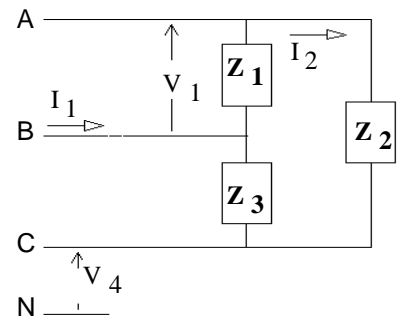

a) If this is a balanced load, what can be said about the  $Z$ 's?

b) Which of the voltages shown is commonly referred to as the line voltage?

c) Which of the currents shown is commonly referred to as the line current?

d) What is the relationship between  $V_1$  and  $V_4$ ?

e) What is the relationship between  $I_1$  and  $I_2$ ?

f) Is this load connected Y or  $\Delta$ ?

g) Could we find an equivalent load connected the other way ( $\Delta$  if now Y, or Y if now  $\Delta$ )? NO YES  
 If yes what  $Z$  values should be used? Finish one of these two expressions:

$$Z_{\Delta} =$$

$$Z_Y =$$

**ECE3600 Final given: Fall 16 p2**

3. A source and load are connected to a model of a non-ideal transformer as shown. All the variables shown or referred to in the questions are scalar or magnitudes of complex numbers. The same should be true of your answers. Where possible, express answers mathematically.

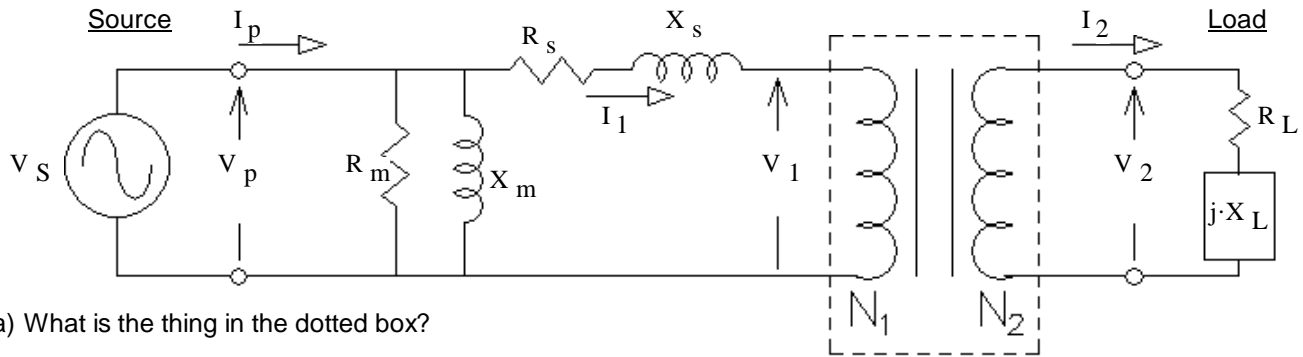

- a) What is the thing in the dotted box?
- b) What is the relationship between  $V_1$  and  $V_2$ ?
- c) What is the relationship between  $I_1$  and  $I_2$ ?
- d) Can the dotted box and the load be replaced with a simpler equivalent,  $R_{eq} + j \cdot X_{eq}$ ?      NO    YES  
 If yes, express:       $R_{eq} =$        $X_{eq} =$

these may be used in expressions below

e) Express  $I_1$  in terms of impedances and  $V_p$ . (Please remember that these variables are all scalar or magnitudes.)

$I_1 =$

- f) Express the real power provided by the source in terms of impedances,  $V_p$  and  $I_1$ .  $P_S =$
- g) Express the reactive power provided by the source in terms of impedances,  $V_p$  and  $I_1$ .  $Q_S =$
- h) Express  $I_p$  in whatever terms you can find above. ("above" means in the figure and/or answers of this problem.)  
 $I_p =$
- i) Express the efficiency in whatever terms you can find above.  $\eta =$

4. The following questions pertain to a 3-phase synchronous machine.

- a) Label all the phasors and angles shown.
- b) Is this phasor diagram for a motor or a generator?
- c) Judging by the phasor diagram, is the machine making + or - reactive power?
- d) Label the diagram with the voltage and current labels used in a). Also label anything else of importance.
- e) Express the relationship between the 3 voltage phasors above (they can be complex numbers).  $E_A =$

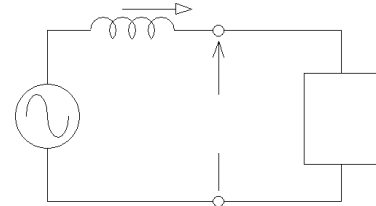
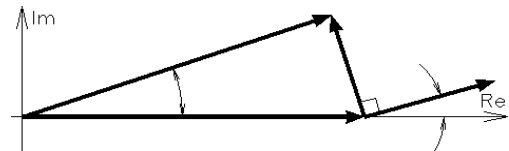

5. The following questions pertain to a 3-phase induction motor. A model of one phase is shown.

a) What is the variable "s" called?

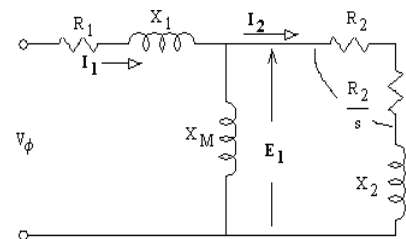

b) Write an expression for the combined impedance,  $Z$ .

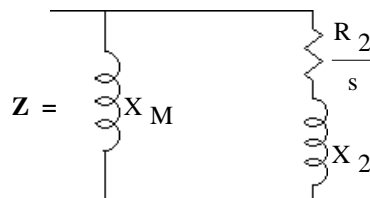

## ECE3600 Final given: Fall 16 p3

- c) Write an expression for  $E_1$  in terms of  $V_\phi$  and the impedances above (possibly including  $Z$ ).  $E_1 =$
- d) Write an expression for  $|I_2|$  in terms of  $E_1$  and the impedances above.  $|I_2| =$
- e) Express the stator-copper-loss in terms found above.  $P_{SCL} =$
- f) Express the rotor-copper-loss in terms found above.  $P_{RCL} =$
- g) Express the air-gap power in terms found above.  $P_{AG} =$
- h) Express the power converted to mechanical power in terms found above.  $P_{conv} =$

### F16 Open book

1. (36 pts) A separately excited dc motor is rated at 2-hp, 1000rpm, armature: 320 V 8A, field: 320 V 0.6A. Unless stated otherwise, assume rated voltages below.
- a) The motor is loaded with an unknown mechanical load. It spins at 1100rpm and the armature current is 4A. The unknown load is: (circle one)
    - i) 2 hp
    - ii) Less than 2 hp
    - iii) Greater than 2 hp
    - iv) Can't tell from the given information
  - b) Find  $R_A$  from the information given in a) and the ratings. Hint: See the final item of the DC motor notes

If you can't find  $R_A$ , mark an X here \_\_\_\_\_ and use  $6\Omega$  for the rest of the problem.

- c) Find the rotational losses at when operated at full load.  $P_{rot} = ?$

- d) Find the unknown load power from part a). The rotational loss torque is proportional to the motor speed.

Hint: This also means that the rotational loss is proportional to  $n^2$ , like this:  $P_{rot2} = P_{rot1} \cdot \frac{n_2^2}{n_1^2}$

**This is the load for the rest of the problem.**

- e) Find the overall efficiency (includes power needed for the field) when operated at the load you just found.

- f) If this seems off to you, remember that this is a small load and take this to the limit. That is, consider the no-load efficiency. What is the no-load efficiency? Hint: This is a "duh" question.

**The field voltage is reduced to 160V and field flux drops to half of its former value.**

**The armature is still at the rated voltage. The new speed is 1760rpm.**

The load watts may depend upon the speed, but is known for the speed used in part d).

- g) Find the new  $E_A$  Hint: it can't be greater than  $V_T$

- h) Find the new  $P_{conv}$

- i) If the load power were also proportional to  $n^2$ , just like the rotational loss, then  $P_{conv}$  would be proportional to  $n^2$ . Find the new  $P_{conv}$  using this assumption and compare it to that found above.

## ECE3600 Final given: Fall 16 p4

2. (36 pts) A 138 kV transmission line has the following length and line parameters.

S := siemens

$$\text{len} := 120 \cdot \text{km} \quad r := 0.10 \cdot \frac{\Omega}{\text{km}} \quad x := 0.7 \cdot \frac{\Omega}{\text{km}} \quad g := 0 \cdot \frac{\text{S}}{\text{km}} \quad y := 5.5 \cdot 10^{-6} \cdot \frac{\text{S}}{\text{km}}$$

- a) Choose the most appropriate model for this transmission line and draw it, including the impedance and/or admittance value(s). Add a 3 $\phi$  load at the receiving end of the transmission line.

The line voltage at the **load** is 138kV. The line current ( $I_{\text{Line}}$ ) is 80A and it lags the line-to-neutral voltage at the load by 3 $^\circ$ .

- b) Find the source phase voltage,  $V_S$ , magnitude and phase.  $V_S = ?$  Clearly state what you are using as the 0 $^\circ$  reference.

- c) What is the source line voltage (magnitude)?

- d) Find the load current in your model,  $I_R$  in a complex-number form.  $I_R = ?$

- e) What is the "power angle" ( $\delta$ )?

- f) Find the total P and Q at the receiving end (including  $Z_{\text{shunt}}$ ).  
(use  $I_{\text{Line}}$ )  
hint:  $S = V \cdot \overset{\text{complex conjugate}}{I}$

- g) Find the  $\theta$  of this S.

- h) How much capacitive Q needs to be added at the receiving end to make the line current ( $I_{\text{Line}}$ ) lead the line-to-neutral voltage at the load by 3 $^\circ$  instead of lagging by 3 $^\circ$ . Assume answer to part f) remains the same.

- i) Assuming the line current magnitude is still 80A and that  $|V_R|$  remains the same as used in part b) (not great assumptions), Find the new  $|V_S|$  with this capacitive Q in place.

- j) If the sending end voltage had remained the same (instead of the receiving end), would  $|V_R|$  have increased or decreased with the addition of the capacitive Q ?

3. (18 pts) A 1/2-hp, 120-V, 60-Hz, single-phase, capacitor-run, induction motor has two different windings set 90 $^\circ$  apart in the motor housing. At startup, the run winding uses 500W and 5.5A and the start winding (with an 80 $\mu$ F series capacitor) uses 250W and 4.8A.

- a) Assume that the Q for the start winding with the capacitor is negative.  
Find the phase angle difference between the two currents.

- b) Find the impedance (R and X) of the start winding **without** the series capacitor.  $C := 80 \cdot \mu\text{F}$  excluded

# ECE3600 Final given: Fall 16 p5

4. Do you want your grade and scores posted on the Internet?  
If your answer is yes, then provide some sort of alias:

otherwise, leave blank

The grades will be posted on line in pdf form in alphabetical order under the alias that you provide here. I **will not** post grades under your real name or an alias that looks like a real name or u-number. It will show the homework, lab, and exam scores of everyone who answers here.

## Answers

1. a)  $Q_{S1} + Q_{S2} = Q_{Rline} + Q_{L1} + Q_{L2}$     b) NO    c) NO    d)  $I_{line} = \frac{\sqrt{(P_{S1} + P_{S2})^2 + (Q_{S1} + Q_{S2})^2}}{V_S}$

e)  $I_{line} = \frac{\sqrt{(P_{L1} + P_{L2})^2 + (Q_{L1} + Q_{L2})^2}}{V_L}$     f)  $I_{L1} = \frac{\sqrt{(P_{L1})^2 + (Q_{L1})^2}}{V_L}$     g)  $\eta = \frac{P_{L1} + P_{L2}}{P_{S1} + P_{S2}}$   
OR  $\eta = \frac{P_{L1} + P_{L2}}{P_{L1} + P_{L2} + P_{Rline}}$

2. a)  $Z_1 = Z_2 = Z_3$     b)  $V_1$     c)  $I_1$     d)  $V_1 = \sqrt{3} \cdot V_4$     e)  $I_1 = \sqrt{3} \cdot I_2$

f)  $\Delta$     g)  $Z_{\Delta} = 3 \cdot Z_Y$  either answer  $Z_Y = \frac{Z_{\Delta}}{3}$  OR  $\frac{Z_1}{3}$

3. a) Ideal transformer    b)  $\frac{V_1}{V_2} = \frac{N_1}{N_2} = \frac{I_2}{I_1}$     c)  $I_2$     d)  $R_{eq} = R_L \cdot \left(\frac{N_1}{N_2}\right)^2$      $X_{eq} = X_L \cdot \left(\frac{N_1}{N_2}\right)^2$

e)  $I_1 = \frac{V_p}{\sqrt{\left[ R_s + R_L \cdot \left(\frac{N_1}{N_2}\right)^2 \right]^2 + \left[ X_s + X_L \cdot \left(\frac{N_1}{N_2}\right)^2 \right]^2}}$  OR  $\frac{V_p}{\sqrt{(R_s + R_{eq})^2 + (X_s + X_{eq})^2}}$

f)  $P_S = \frac{V_p^2}{R_m} + I_1^2 \cdot (R_s + R_{eq})$     g)  $Q_S = \frac{V_p^2}{X_m} + I_1^2 \cdot (X_s + X_{eq})$     h)  $I_p = \frac{\sqrt{P_S^2 + Q_S^2}}{V_p}$     i)  $\eta = \frac{I_1^2 \cdot R_{eq}}{P_S}$

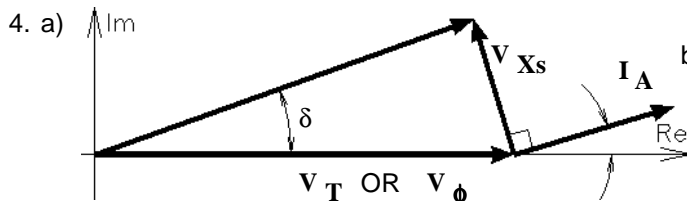

e)  $E_A = V_{\phi} + V_{Xs} = V_{\phi} + I_A \cdot j \cdot X_s$

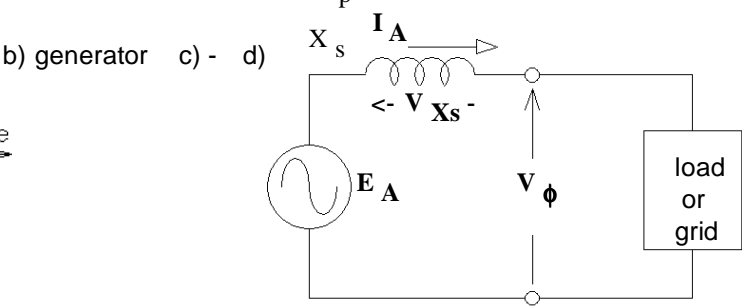

5. a) The slip

b)  $Z = \frac{1}{\frac{1}{j \cdot X_m} + \frac{1}{\left(\frac{R_2}{s} + j \cdot X_2\right)}}$     c)  $E_1 = V_{\phi} \cdot \frac{Z}{R_1 + j \cdot X_1 + Z}$     d)  $|I_2| = \frac{|E_1|}{\sqrt{\left(\frac{R_2}{s}\right)^2 + X_2^2}}$

e)  $P_{SCL} = 3 \cdot [ (|I_1|)^2 \cdot R_1 ]$     f)  $P_{RCL} = 3 \cdot [ (|I_2|)^2 \cdot R_2 ]$     g)  $P_{AG} = 3 \cdot \left[ (|I_2|)^2 \cdot \frac{R_2}{s} \right]$

h)  $P_{conv} = (1 - s) \cdot P_{AG} = P_{AG} - P_{RCL}$

## Open Book

1. a) ii)    b) 6.67-Ω    c) 642-W    d) 397-W    e) 26.9-%    f) 0-%    g) 235-V    h) 3004-W    i) 3004-W

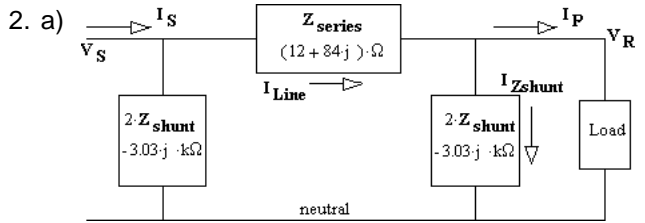

b) 81.3 kV / 4.7°    c) 140.7-kV    d) 85.5 A / -20.9°    e) 4.7-deg  
f) 19.1-MW    1-MVAR    g) 3-deg    h) -2-MVAR    i) 80.6-kV  
j) increased

3. a) 105-deg    b) 10.85-Ω    10.64-Ω