

# ECE3600 Final given: Fall 15

**Write Legibly!**

If I can't read what you've written or your answer is ambiguous, I'll assume you don't know.

(34 pts) Questions This part of the exam is **Closed book, Closed notes, No Calculator.**

1. a) Name the common curve shown at right.
- b) Many of the electrical devices we studied contain a part which is characterized by this curve. What part is that?
- c) Name at least 3 issues caused by this part having this characteristic curve.

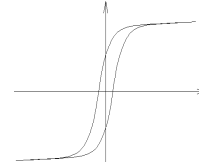

2. a) How many single-phase transformers are required to transform 3-phase power. Give the minimum number.
- b) Show how these single-phase transformers might be connected between the source (shown at left below) and a load (shown at right). Do not create an unbalanced load for the source.

480V, 3-phase

A \_\_\_\_\_

B \_\_\_\_\_

C \_\_\_\_\_

N \_\_\_\_\_

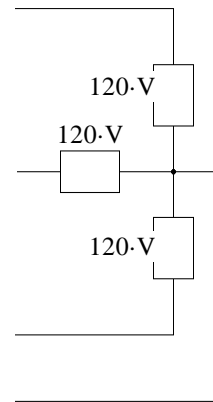

- c) What is the required turns ratio of the transformers you showed above. Since you don't have a calculator, you may show a mathematical expression instead of a number.
3. Most electric motors that we studied slow down if the mechanical load is increased. Are there any that do not (in normal operating range)? Either answer NO or name the exception(s) and indicate how they do respond to increased mechanical load.
4. Most electric motors that we studied draw more current if the mechanical load is increased. Are there any that do not (in normal operating range)? Either answer NO or name the exception(s) and indicate how they do respond to increased mechanical load.
5. a) What DC motor is also commonly used with AC power? Circle one
  1. Separately excited
  2. Series excited
  3. Shunt excited
  4. Permanent magnet
- b) What is it called when it is used with AC power?
- c) Name 2 important characteristics of this type of motor.
- d) Name 2 common uses of this type of motor.
6. The generators at Gadsby (like most generators) are filled with what gas? For what reason?
7. When we visited Terminal substation, we saw three different yards at three different line voltages. Power was also distributed locally at yet another line voltage. List as many of these voltages as you can remember.
8. Large power transformers are filled with \_\_\_\_\_ for two main reasons. Give both reasons.  
fill in blank
9. The breakers used in substations come in two main types, list them and indicate which type was newer technology.
10. What devices control these breakers and where are they located?
11. These control devices utilize voltage and current information. What devices in the substation provide that information?
12. You saw several capacitor banks at Terminal substation. We've talked in class about adding capacitors to correct power factor, but people in the power industry usually talk about the effects of adding capacitors differently. What do they say they add capacitors for?

# F15 Open book

This part of the exam is open book, open notes. You MUST show work to get credit. Show the correct units for each value. Assume values are RMS,  $f := 60\text{-Hz}$  for all problems and normal abc sequence for all  $3\phi$

1. (24 pts) A capacitor (C) is used to partially correct the power factor of a motor to 0.9. That is, the power factor as seen by the source is 0.9. Two ammeters ( $A_1$  and  $A_2$ ) read the currents shown.

Find the following:

- a) The power factor of the motor.  
(Without the additional capacitor)  
As part of your solution, find the P and Q of the motor.

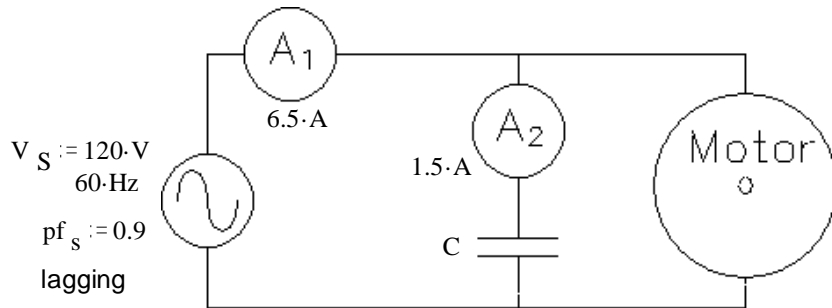

If you can't find this power factor, mark an x here \_\_\_\_\_ and assume  $pf_m = 0.85$  for the rest of the problem.

You may salvage some points from a) if you find the motor Q from this  $pf_m$ , otherwise skip to b)

- b) How much current flows through the motor (magnitude).  
c) Add an additional component to the drawing above in order to completely correct the power factor. Find the value of the component. Use the space below and on the next page.  
d) With this new component in place, what does ammeter  $A_1$  read now?

2. (13 pts) Find the following:

- a) The line current that would be measured by an ammeter.  
b) The power consumed by the three-phase load.  
Don't include power lost in the lines.

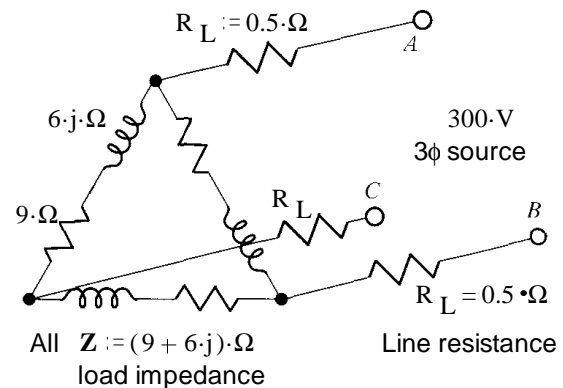

- c) What is the line voltage at the load? Just magnitude.

3. (35 pts) A separately excited dc motor is rated at 2-hp, 1000rpm, armature: 200 V 11A, field: 200 V 0.6A.

Unless stated otherwise, assume rated voltages below.

- a) The motor is loaded with an unknown mechanical load. It spins at 1200rpm and the armature current is 3A. The unknown load is: (circle one)

- i) 2 hp    ii) Less than 2 hp    iii) Greater than 2 hp    iv) Can't tell from the given information

- b) Find  $R_A$  from the information given in a) and the ratings. Hint: See the final item of the DC motor notes

If you can't find  $R_A$ , mark an X here \_\_\_\_\_ and use  $4\Omega$  for the rest of the problem.

- c) Find the rotational losses at when operated at full load.  $P_{rot} = ?$

- d) Find the unknown load power from part a). The rotational loss torque is proportional to the motor speed.

Hint: This also means that the rotational loss is proportional to  $n^2$ , like this:  $P_{rot2} = P_{rot1} \cdot \frac{n_2^2}{n_1^2}$

**This is the load for the rest of the problem.**

- e) Find the overall efficiency (includes power needed for the field) when operated at the load you just found.

- f) If this seems off to you, remember that this is a small load and take this to the limit. That is, consider the no-load efficiency. What is the no-load efficiency? Hint: This is a "duh" question.

The field voltage is reduced to 100V and field flux drops to half of its former value.  
The armature is still at the rated voltage. The new speed is 2040rpm.

ECE3600  
Final Fall 15 p3

- g) Find the new  $E_A$  Hint: it can't be greater than  $V_T$
- h) Find the new  $P_{conv}$
- i) If the load power were also proportional to  $n^2$ , just like the rotational loss, then  $P_{conv}$  would be proportional to  $n^2$ . Find the new  $P_{conv}$  using this assumption and compare it to that found above.

4. (34 pts) A 138 kV transmission line has the following length and line parameters.

S := siemens

$$\text{len} := 100 \cdot \text{km} \quad r := 0.12 \cdot \frac{\Omega}{\text{km}} \quad x := 0.7 \cdot \frac{\Omega}{\text{km}} \quad g := 0 \cdot \frac{\text{S}}{\text{km}} \quad y := 5 \cdot 10^{-6} \cdot \frac{\text{S}}{\text{km}}$$

- a) Choose the most appropriate model for this transmission line and draw it, including the impedance and/or admittance value(s). Add a 3 $\phi$  load at the receiving end of the transmission line.

The line voltage at the **source** is 138kV. The line current ( $I_{Line}$ ) is 120A and it leads the line-to-neutral voltage at the source by 12°.

- b) Find the load phase voltage,  $V_R$ , magnitude and phase.  $V_R = ?$   
Clearly state what you are using as the 0° reference.

- c) What is the line voltage at the load (magnitude)?

- d) Find the load current in your model,  $I_R$  in a complex-number form.  $I_R = ?$

- e) What is the "power angle" ( $\delta$ )?

- f) Find the impedance of one phase of the load, assuming Y-connected.

- g) Find the power consumed by the entire load.

- h) Find the power factor of the load.

- i) The power factor of the load is leading or lagging? circle one

- j) Find the power factor as seen by the source.

5. (20 pts) A 1/2-hp, 120-V, 60-Hz, single-phase, capacitor-run, induction motor has two identical windings set 90° apart in the motor housing. Without any capacitors, each winding draws 6 A at 32° lag when the rotor is locked and 3 A at 43° lag when the motor is running at its rated speed.

- a) Find the ideal capacitor to place in series with one of the windings at startup.

Note: the ideal capacitor would create the ideal phase difference between the winding currents.

- b) Find a capacitor to make the current **magnitude** in the two windings exactly the same at rated speed. (Don't worry about the phase angles.)

**ECE3600 Final given: Fall 15 p4**

- c) As a compromise, choose a standard value capacitor (a nice round number) about midway between your answers above.
- d) With the compromise capacitor in place, find the actual phase difference between the two winding currents at startup.

6. Do you want your grade and scores posted on the Internet?  
If your answer is yes, then provide some sort of alias:

The grades will be posted on line in pdf form in alphabetical order under the alias that you provide here. I **will not** post grades under your real name or an alias that looks like a real name or u-number. It will show the homework, lab, and exam scores of everyone who answers here.

**Answers** \_\_\_\_\_ otherwise, leave blank

1. a) B-H curve or Hysteresis curve      b) The core  
c) Core losses      Nonlinearities, 3rd harmonic currents  
requires more windings so that the core flux can be less

Sets voltage limits      3 of these  
Requires larger, heavier cores

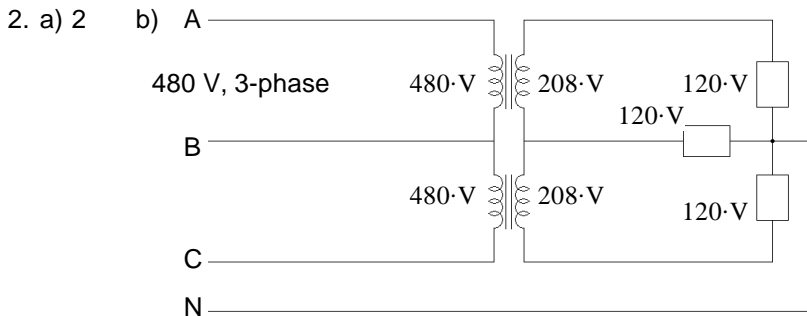

c)  $\frac{480 \cdot V}{208 \cdot V} = 2.31$

3. Synchronous motors do not slow down, their speed remains constant  
4. NO, all electric motors draw more current if the mechanical load is increased  
5. a) 2.      b) Universal motor

5. c) High torque      High power-to-weight ratio      High power-to-size ratio      2 of these  
Torque increases significantly as load is increased      Noisy

- d) Hand drill      Vacuum cleaner      Blender      Food processor      2 of these or many others  
Weed eater      Electric yard devices

6. Hydrogen      Heat dissipation      7. 46-kV      138-kV      345-kV      12.47-kV

8. Oil      Oil is a better insulator than air      Oil is used to keep the transformers cool

9. Oil filled (old)      Gas (SF<sub>6</sub>) filled (newer)      10. Relays in the control buildings

11. Current transformers (CTs)      Voltage or Potential Transformers (VTs or PTs)      12. To increase the voltage

**Open Book** 1. a) 0.804      b) 7.28·A      c) Add another 62.6μF capacitor in parallel with the first.      d) 5.85·A

2. a) 43.0·A      b) 16.6·kW      c) 268.3·V

3. a) ii)      b) 3.92·Ω      c) 234·W      d) 227.6·W      e) 31.6·%      f) 0·%      g) 160·V      h) 1632·W      i) 1632·W

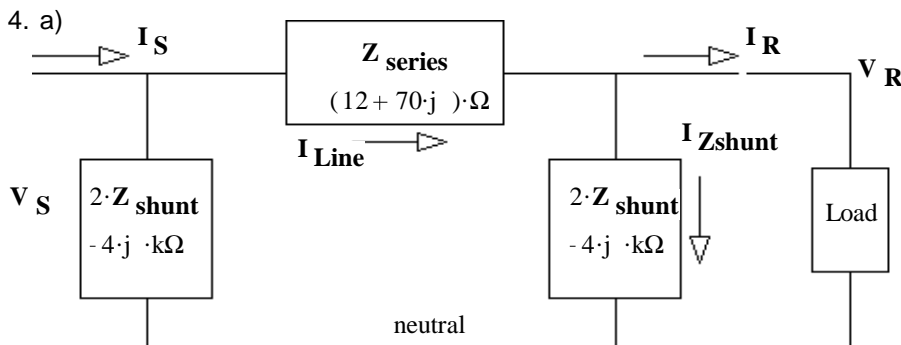

- b) 80.46·kV - 6.08·deg  
c) 139.4·kV  
d) 115.4·A      2.46·deg  
e) 6.08·deg  
f) (689.8 - 103.5j)·Ω  
g) 27.54·MW  
h) 0.989      j) 0.934

5. a) 70.3·μF      b) 48.6·μF      c) about 60·μF      d) 95.2·deg