

ECE3600 Final given: Fall 14

Write Legibly!

If I can't read what you've written or your answer is ambiguous, I'll assume you don't know.

(40 pts) Questions

This part of the exam is **Closed book, Closed notes, No Calculator.**

- Give the two largest sources of energy used to produce electricity in the US. List the largest first.
 -
 -
- Give the approximate efficiencies of each type of power plant:
 - Hydroelectric
 - Rankin-cycle steam turbine plants, regardless of the source of heat. (coal, oil, gas-steam, nuclear, solar-steam, geothermal)
 - Single-cycle gas turbine
 - Combined-cycle gas turbine
- What does it mean when a 3-phase system is "balanced"?
- Name 3 sources of electrical power for the grid which do not produce greenhouse gasses by normal operation.
- Name at least 3 issues caused by the B-H hysteresis curve.

- You have a 320/80-V, 640-VA transformer.
 - Can you use this transformer to transform 320 V to 240 V? If yes, show the connections and compute the new VA rating.

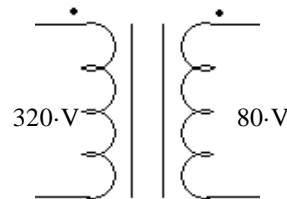

- Can you use this transformer to transform 160 V to 120 V? If yes, what is the maximum real power that could be transformed?
 - Is there a requirement for the load to actually transform this much real power? if yes, say what.
- When accounting for the non-ideal characteristics of a power transformer, which of the following is the most important (least often neglected)?

magnetization reactance	core losses	winding losses	leakage reactance
-------------------------	-------------	----------------	-------------------

- Is there a readily available device (perhaps made for a different use, which could regulate the speed of a synchronous motor? If yes, name the device,
- How can you reverse the direction of rotation of a capacitor-start motor? That is, reverse the direction it starts. Choose from these answers.
 - Reverse the leads to the start winding.
 - Reverse the leads to the main winding.
 - Reverse the leads to both windings.
 - Change which winding has the capacitor.
 - Reverse the leads to the capacitor.
 - Reverse the positions of the capacitor and the start (second) winding.

- In the space at right, sketch the torque-speed curve of a series-wound DC motor (field in series with rotor).
 - If this type of motor is used with an AC source, what is it called?
 - Name at least 2 common uses of this type of motor.



- List at least 3 common long-distance high-voltage transmission line voltages given in class.
- What insulates the wires from one another in an overhead transmission line?
- What does the term "bundling" mean for high-voltage transmission lines?
 - It is typically used for transmission lines with line voltages \geq _____ fill in blank
 - Name the 3 most important reasons for doing this. (advantages)
 - Are there disadvantages? Answer no or name one or more.

F14 Open book

This part of the exam is open book, open notes. You MUST show work to get credit. Show the correct units for each value. Assume values are RMS, $f := 60\text{-Hz}$ for all problems and normal abc sequence for all 3ϕ

1. (31 pts) Consider the single-phase circuit shown. Two ammeters (A_1 and A_2) read the currents shown. Find the following:

- a) The complex power supplied by the source and the power factor as seen by the source.

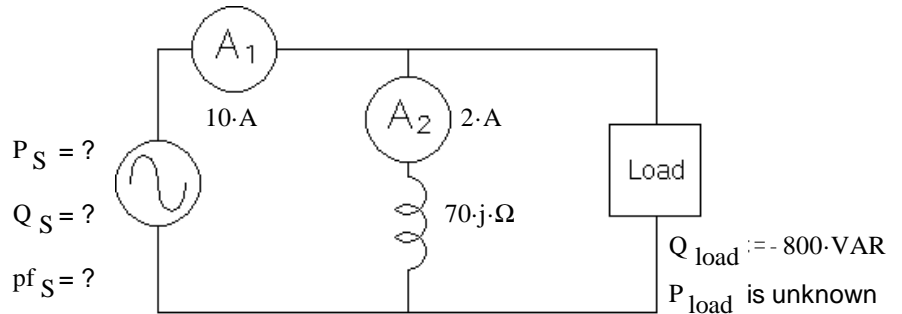

- b) How much current flows through the load (magnitude).
- c) The power factor of the load.
- d) Add an additional component to the drawing above in order to completely correct the power factor. Find the value of the component.
- e) With this new component in place, what does ammeter A_1 read now?

2. (34 pts) A separately excited dc motor is rated at 2-hp, 1200rpm, armature: 150 V 14A, field: 150 V 0.8A.

- a) The field is connected to the rated voltage and then you spin this motor with another motor at 900rpm. Nothing but a voltmeter is hooked to the armature terminals and it measures 92 V. $1\text{-hp} = 745.7\text{-W}$
Find R_A from this information and the ratings.

If you can't find R_A , mark an X here _____ and use 2Ω for the rest of the problem. Unless stated otherwise, assume rated voltages below.

- b) Find the rotational losses at when operated at full load. $P_{rot} = ?$
- c) Find the overall efficiency (includes power needed for the field) when operated at full load.
- d) Find the no-load armature current. Show the algebra needed to find I_A from the basic equations. The rotational losses are proportional to the motor speed.
Hint 1: This also means that the rotational losses are proportional to E_A , like this: $P_{rot2} = P_{rot1} \cdot \frac{E_{A2}}{E_{A1}}$
Hint 2: This turns out to be amazingly easy to calculate, no quadratic required.
- e) Find the no-load shaft speed.
- f) The mechanical load on the shaft is increased and the motor slows down to: $n_{new} := 1300\text{-rpm}$
Find the load power at this speed.
- g) The field voltage is reduced to 120V and the armature is left at the rated voltage. The load is then adjusted so that the speed is again 1300rpm. Find the armature current at this field voltage.
- h) Would it be OK to operate this way for a long time?

3. (35 pts) A 230 kV (nominal) transmission line has the following length and line parameters. S := siemens

len := 200·km r = ? x = ?
 (will be found in problem) g := 0 · $\frac{S}{km}$ y := 4 · 10⁻⁶ · $\frac{S}{km}$

a) Choose the most appropriate model for this transmission line and draw it, including the impedance and/or admittance value(s) you can find at this time. Add a 3φ load at the receiving end of the transmission line.

The line voltage at both the sending and the receiving end are both 230kV. The power angle is 12°. The load at the receiving end is S_R := 90·MVA it's power factor is 0.94.

b) Judging by the voltages, the load power factor is most likely: leading lagging (circle one)

c) Find the line current to the load, I_R (not I_{Line}) as a complex number.

Clearly state what you are using as the 0° reference.

d) Find the impedance of one phase of the load, assuming Y-connected.

e) Find the line current in your model, I_{Line} (not I_S) in a complex-number form. I_{Line} = ?

f) Find the series impedance of the line. Z_{series} = ?

If your answer to for Z_{series} comes out unreasonable, go back and rethink your answer to part b). Rework your other answers as necessary.

g) Find the missing line parameters. r = ? x = ?

h) How much real power does the source supply?

i) What is the efficiency of this line?

4. (20 pts) A one-line drawing of a 3-phase system is shown. Some 3-phase Ps and Qs are also shown. The 3-phase transformer is made of 3 individual single-phase transformers, each with a 2:1 turns ratio. They are hooked up Y - Δ step-down. Remember that bus and line voltages are measured the same way. Find the complex power consumed by load 1. Hints: Work from load 2 back and if you don't use Ps and Qs to solve this problem it will be VERY HARD!

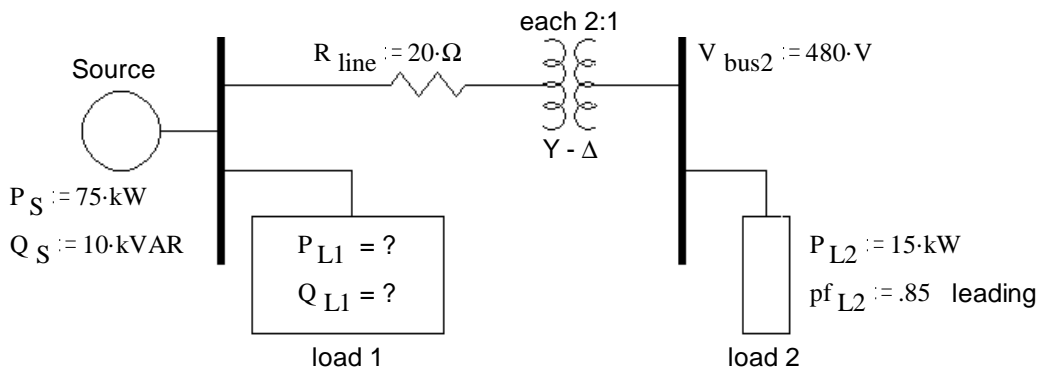

ECE3600 Final given: Fall 14 p4

5. Do you want your grade and scores posted on the Internet?
If your answer is yes, then provide some sort of alias:

_____ otherwise, leave blank

The grades will be posted on line in pdf form in alphabetical order under the alias that you provide here. I **will not** post grades under your real name or an alias that looks like a real name or u-number. It will show the homework, lab, and exam scores of everyone who answers here.

Answers

1. Coal 2. Natural Gas (partial credit if Nuclear listed as #2)

2. a. $\geq 90\%$ b. 35 - 40% c. $\sim 38\%$ d. 55 - 60%

3. The 3 voltages are equal, the 3 currents are equal and the 3 loads are equal.

4. Hydroelectric wind solar (steam or solar-cells) nuclear geothermal 3 of these

5. Core losses Nonlinearities, esp. 3rd harmonic currents Requires larger, heavier cores
Sets voltage limits Requires more windings so that the core flux can be less

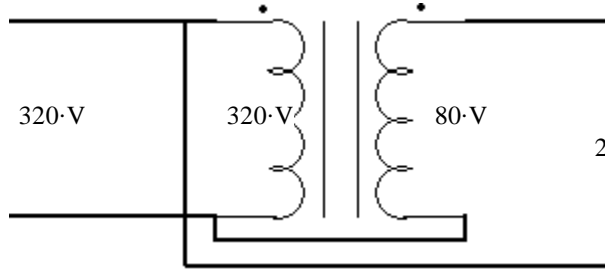
6. a)  1.92-kVA b) YES, half voltages above 960-W
c) YES, pf = 1

7. leakage reactance

8. Yeah, a VFD (variable Frequency Drive) made for induction motors would work.

9. a) b) d)

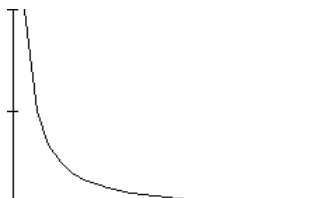
10. a)  b) Universal motor
c) Hand drill Vacuum cleaner Blender 2 of these
Food processor Weed eater Electric yard devices

11. 12.47-kV 46-kV 115-kV 230-kV 345-kV 500-kV 765-kV 3 of these

12. Air (and distance) 13. a) Using more than one conductor per phase. b) 345-kV c) Reduce corona discharge
Decrease line inductance Increase line capacitance d) Costs more

Open Book

1. a) $1.3 - 0.52j$ kVA 0.928 b) 10.9-A c) 0.852 d) Add a 100mH inductor in parallel with the first. e) 9.28-A

2. a) $1.95 \cdot \Omega$ b) 226-W c) 67.2-% d) 1.84-A e) 1432-rpm f) 920-W g) 22.4-A h) NO

3. a) Medium-length line model:

b) leading

c) $226 \text{ A} / 19.9^\circ$

If V_R is the 0° reference.

d) $588 \Omega / -19.9^\circ$

e) $249 \text{ A} / 31.5^\circ$

f) $111.4 \Omega / 64.5^\circ$

g) $0.240 \cdot \Omega$ $0.503 \cdot \Omega$

h) 93.54-MW

i) 90.45-%

4. $57.75 + 19.3j$ kVA

