

ECE3600 Final given: Fall 11

Write Legibly! If I can't read what you've written or your answer is ambiguous, I'll assume you don't know.

(54 pts) Questions This part of the exam is **Closed book, Closed notes, No Calculator.**

1. You have a 320/80-V, 640-VA transformer.
Can you use this transformer to transform 320 V to 240 V? If yes, show the connections and compute the new VA rating.

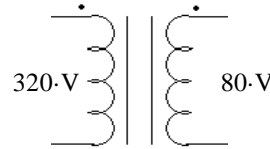

2. When accounting for the non-ideal characteristics of a power transformer, which of the following is the most important (least often neglected)?
magnetization reactance core losses winding losses leakage reactance
3. At the dispatch center we saw a large display board showing a one-line diagram of the power system. At the top of this some red numbers displayed several things, list one or more.
4. When we visited Terminal substation, we had to wear protective clothing (The old shirts, sweatshirts, or jackets). What was special about this clothing and/or what did it protect us from?
5. When we visited Terminal substation, we saw three different yards at three different line voltages. Power was also distributed locally at yet another line voltage. List one or more of the four voltages.
6. Large power transformers are filled with _____ for two main reasons. Give one or both reasons.
fill in blank
7. The breakers used in substations came in two main types, list them and indicate which type was newer technology.
8. List up to four of the most important things that you saw in the control room(s) at Terminal substation.
9. a) List up to 3 different synchronous motor speeds in the US, in rpm.
b) How are typical induction motor rated speeds related to the synchronous motor speeds?
c) When the power is first turned on to an induction motor, what is the slip? $s = ?$
d) When an induction motor is operated at its rated output, what is a typical slip? $s = ?$
10. An induction motor is operated with a variable-frequency drive.
a.1) How is the motor operated at slower-than-normal speeds?
a.2) Is there something else which must also be reduced? If yes, what and why?
b) How is the motor operated at higher-than-normal speeds?
11. An induction motor with just one winding connected to an AC source has what interesting behavior?
12. a) The torque-speed curves of 2 induction motors are shown at right. Only one equivalent circuit parameter is different between the two. What is it?
b) This parameter is bigger in which motor?
c) The starting current is bigger in which motor?

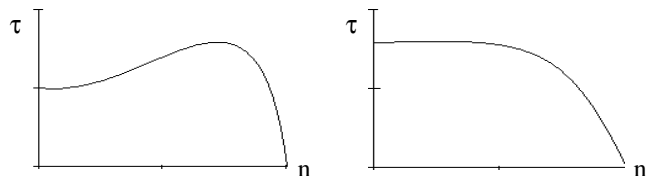

13. How can you reverse the direction of rotation of a single-phase capacitor-run motor? That is, reverse the start direction.
a) Reverse the leads to the capacitor. b) Reverse the positions of the capacitor and the start (second) winding.
c) Reverse the leads to the main winding. d) Reverse the leads to the start winding.
e) Reverse the leads to both the main and the start windings.

Will this also work for a capacitor-run motor?

ECE3600 Final given: Fall 11 p2

14. a) In the space at right, sketch the torque-speed curve of a series-wound DC motor (field in series with rotor).

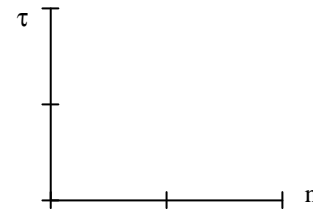

b) If this type of motor is used with an AC source, what is it called?

c) Name some common uses of this type of motor.

15. a) High-voltage transmission lines with line voltages \geq _____ often use more than one conductor per phase. What is this called?
fill in blank

b) Name some effects of this.

16. Is it OK to load a transmission line above the surge impedance loading for long periods of time?

17. a) Transmission lines can be modeled in 3 different ways. List the 3 model types below.

b) How do you decide which model to use? Give specific number ranges of a specific variable below.

A note about how this section was graded: Some of the questions had multiple answers, especially those that asked about the field trips. More correct answers = more points. More on one balanced less on another. What the average student remembered was worth about 80%. Incorrect answers deducted points, but less if the student indicated doubt.

Do you want your grade and scores posted on the Internet?

If your answer is yes, then provide some sort of alias: _____

otherwise, leave blank

The grades will be posted on line in pdf form in alphabetical order under the alias that you provide here. I will not post grades under your real name. It will show the homework, lab, and exam scores of everyone who answers here.

F11 Open book

1. (30 pts) A 3-phase induction motor is Y-connected to a 480-V bus. It draws 9kW of real power and has a power factor of 0.9. Some more knowns:

$$X_M := 100 \cdot \Omega$$

$$R_C := \infty$$

$$\text{Input power: } P_{in} := 9 \cdot \text{kW} \quad \text{at } \text{pf} := 0.9$$

$$E_1 := (255 - j \cdot 16) \cdot \text{V}$$

$$n := 1710 \cdot \text{rpm}$$

$$\text{Rotor copper loss: } P_{RCL} := 426 \cdot \text{W}$$

$$\text{The output shaft torque: } \tau_{load} := 43 \cdot \text{N} \cdot \text{m}$$

$$\text{Stator copper loss: } P_{SCL} := 467 \cdot \text{W}$$

DON'T FORGET: Your powers are for the whole motor and your model is only for ONE phase.

a) Draw the correct model for this motor. This will be your working drawing, so you may want to add information from above. Leave room on your drawing for current, voltage, and component values to be added later.

b) Find the line current. $I_L = ?$

c) Find R_1

d) Find $|I_2|$

e) Find P_{AG}

f) Find s

g) Find R_2

h) Find the shaft output power

i) Find the mechanical power losses (all lumped together).

j) Find the overall machine efficiency

2. (27 pts) A 2-hp, shunt excited dc motor has the following nameplate information: 160 V, 1200 rpm, 14 A.

The 14 A includes 1.8 A of field current. Assume rotational losses are 300 W and are constant.

$$1 \cdot \text{hp} = 745.7 \cdot \text{W}$$

a) Find R_A

b) Find the no-load armature current. Show the algebra needed to find I_A from the basic equations.

c) Find the no-load shaft speed.

d) Is this speed likely to damage the motor?

ECE3600 Final given: Fall 11 p3

- e) An incompetent operator (I ain't namin' no names) disconnects the field winding and the field flux drops to a residual value which is 10% of its correct value. Find the new no-load shaft speed. Note: because the rotational losses are constant, it is OK to use the same I_A and E_A as you found and used in parts b) and c).
- f) What may well happen to the motor at this speed?

3. (32 pts) A 230 kV transmission line has the following length and line parameters. S := siemens

$$\text{len} := 100 \cdot \text{km} \quad r := 0.15 \cdot \frac{\Omega}{\text{km}} \quad x := 0.6 \cdot \frac{\Omega}{\text{km}} \quad g := 0 \cdot \frac{\text{S}}{\text{km}} \quad y := 4 \cdot 10^{-6} \cdot \frac{\text{S}}{\text{km}}$$

- a) Choose the most appropriate model for this transmission line and draw it, including the impedance and/or admittance value(s).

A 3 ϕ load is connected at the receiving end of the transmission line. The load consumes 180MW of real power and has a power factor of 0.9, **leading**. Add it to the drawing above. The line voltage at the **load** is 230 kV. Assume the phase angle of the load voltage on your drawing, V_R , is $\underline{0^\circ}$.

- b) Find the line current, I_{Line} (not I_S) in a complex-number form. $I_{\text{Line}} = ?$
- c) Same load and conditions as part b). Find the source phase voltage, V_S , magnitude and phase. $V_S = ?$
- d) What is the line voltage at the source (magnitude)?
- e) What is the "power angle" (δ)?
- f) Do you see something weird about $|V_R|$ and $|V_S|$? If yes, what is it and what is the cause?
- g) Find the impedance of one phase of the load, assuming Y-connected.
- h) Find the impedance of one phase of the load, assuming Δ -connected.

4. (17 pts) A Single-phase, 1/3-hp, 120-V split-phase motor draws 5 A in its main winding, and 3 A in its start winding when it is first switched on. The two currents lag the supply voltage by 40° and 15° respectively.

- a) Find the initial start-up current (magnitude) and power.
- b) To improve this motor, you want to add a capacitor in series with the start winding so that currents will be 90° out of phase with each other. Find the value of the required capacitor.
- c) The new start winding current is about 2 A. The motor starting torque is proportional to the sine of the angle between the winding currents. It is also proportional to the magnitudes of the currents. How much bigger is the starting torque with the additional capacitor?

Answers

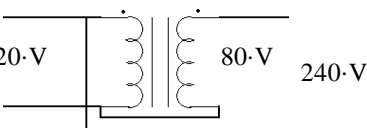
1.  1.92-kVA 2. leakage reactance

3. Time (clock) Power Used locally Power Used by the whole area Power from/to other areas
 System frequency 15 minute timer to make system "whole" when power is required from other areas

4. The FR (Flame Retardant) clothing protected us from burns if we would have been exposed to an electrical arc flash.

5. 12.47-kV 46-kV 138-kV 345-kV

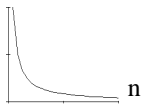
6. Oil Oil is a better insulator than air
Oil is used to keep the transformers cool
7. Oil filled (old) Gas (SF₆) filled (newer)
8. Control relays for the breakers. Communications equipment Battery backup systems.
Equipment to interpret and monitor the information from the voltage and current transformers.
9. a) $\frac{3600 \cdot \text{rpm}}{\text{any_integer}}$ 3600·rpm 1800·rpm 1200·rpm 900·rpm 720·rpm etc..
b) They are a little less (about 5% less) c) 1 d) 0.05 = 5·%
10. a.1) The frequency is less than 60Hz. a.2) The voltage must be reduced to prevent saturation of the core.
b) The frequency is greater than 60Hz.
11. It won't start spinning without outside help
12. R₂ or rotor resistance b) right-most c) left-most
13. c) or d) 14. a)  n b) Universal motor c) Hand drill Vacuum cleaner
Blender Food processor
Weed eater Electric yard devices
15. 345·kV bundling b) Reduce corona discharge Decrease line inductance Increase line capacitance
16. Yes, the surge impedance loading does not set the power limit.
17. 1. Short length < 50 mi length < 80 km
2. Med 50 < length < 150 mi OR 80 < length < 240 km
3. Long length > 150 mi length > 240 km

Open Book

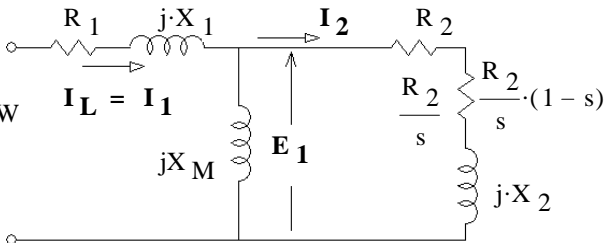
1. a)  b) 12A / -25.84° c) 1.076·Ω d) 11.31·A
e) 8.533·kW f) 0.5 g) 1.112·Ω
h) 7.7·kW i) 407·W j) 85.56%

2. a) 1.08·Ω b) 1.90·A c) 1291·rpm d) NO e) 12910·rpm f) The rotor may fly apart.

3. a) Medium-length line model:

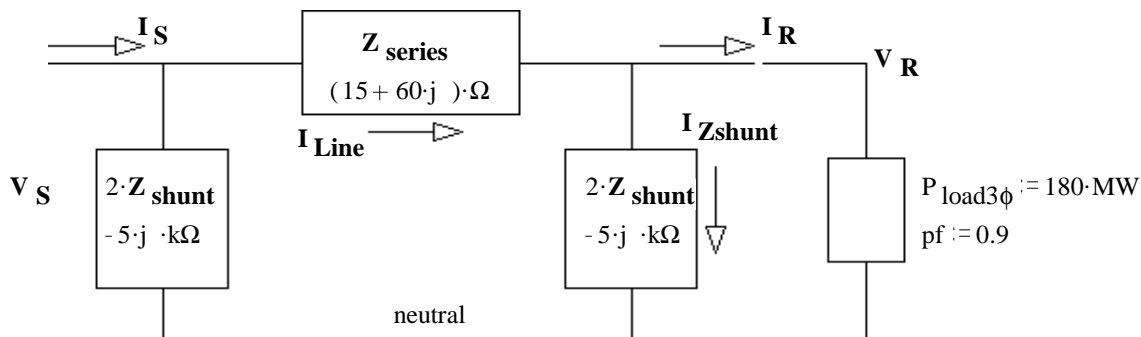

- b) 514A / 28.5° c) 129kV / 13.9° d) 223·kV e) 13.9·deg f) |VR| is bigger than |VS|

- g) 265Ω / -25.8° h) 794Ω / -25.8°

This can happen when the load power factor is leading.

4. a) 7.82·A 807·W b) 47·μF c) 1.58