

ECE 3600 Exam 2 given: Spring 23

DO NOT use erasable ink

First part, Closed book, Closed notes, No reference sheet (pink sheet), No Calculator.

(22 pts) Write Legibly! If I can't read what you've written or your answer is ambiguous, I'll assume you don't know.

1. You have a 320/80-V, 640-VA transformer.
Can you use this transformer to transform 320 V to 240 V? If yes, show the connections and compute the new VA rating.

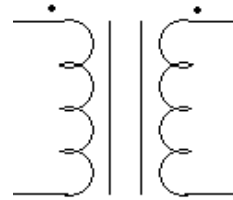

- b) Show the 320-V source and the load.
- c) Could this transformer also be used to transform 160 V to 40 V ? If yes, what is the maximum real power that could be transformed at these voltages?

2. This problem is about 3-phase transformers.

- a) If wired Y - Y, what is the likely phase-angle difference between primary and secondary?
- b) If wired Y - Δ, what is the likely phase-angle difference between primary and secondary?
- c) If wired Δ - Y, what is the likely phase-angle difference between primary and secondary?
- d) If wired Δ - Δ, what is the likely phase-angle difference between primary and secondary?
- e) Is it desirable for at least one winding of a 3-phase transformer to be wired in a certain way? yes no
If yes, which way and why? circle one

3. A transformer is rated at 500/150-V, 1.5-kVA. To find the parameters of this transformer you subject the transformer to two tests.

a) One test is called:

What three things are measured during this test?

One of these three things is adjusted to a specific value. Which one and to what value?

What parts are found from this test?

b) The other test is called:

What three things are measured during this test?

One of these three things is adjusted to a specific value. Which one and to what value?

What parts are found from this test?

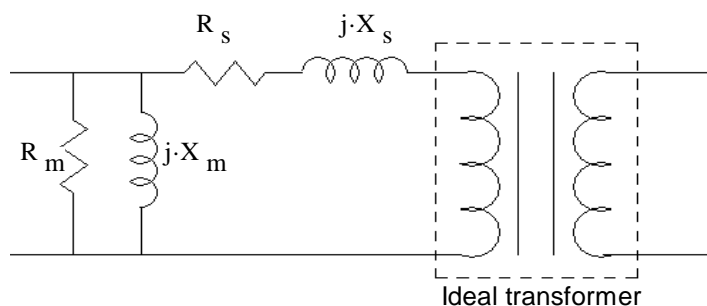

When you are done with this part, turn it in to get the second part.

1. (30 pts) A 3-phase, synchronous generator is not electrically connected to anything. The prime mover is spinning the generator at 3600 rpm. The input torque is 25 Nm. When the field current is 10 A, DC, the terminal voltage is 1000 V.

The field current is raised to 20 A, and the terminal voltage goes up to 2000 V.

The generator is now Y-connected to a 3.6 kV, 60 Hz, bus. The line current is measured at 3 A.

The input torque is still 25 Nm, just enough to overcome rotational losses.

**Exam 2
Sp 23 p2**

a) What is the power angle and/or how much power is being generated?

$$X_s = ?$$

b) Find the synchronous reactance.

If you can't find X_s , or doubt your value, mark here _____ and use $X_s = 25 \Omega$ for the rest of the problem. If it still doesn't seem like you have enough information to answer the following parts, Ask. I will answer questions for points.

c) Find the total reactive power generated.

d) The prime mover torque is increased to $\tau_{in} := 425 \cdot \text{N} \cdot \text{m}$ Find the generated electrical power $P = ?$

The prime mover torque is held at this value for the rest of the problem.

e) Find the power angle. $\delta = ?$

3. continued f) Find the total reactive power generated.

g) The generator operator is told to produce 12 kVAR , no change in real power. Find the required E_A .

h) What does the operator change to get this new E_A , and to what new value.
Hint: reread the initial problem statement.

i) Did the power angle change with the the previous change?
If yes, say whether it increased or decreased. No calculation is required.

2. (28 pts) The following information is for a 3-phase, Y-connected, induction motor:

ECE 3600 Exam 2 Sp 23 p4

$$X_M := 400 \cdot \Omega$$

$$R_C := \infty$$

$$n_m := 1728 \cdot \text{rpm}$$

$$\text{Shaft torque: } \tau_{\text{shaft}} := 50 \cdot \text{N} \cdot \text{m}$$

$$|\mathbf{E}_1| = E_1 := 260 \cdot \text{V}$$

$$|\mathbf{I}_2| = I_2 := 13 \cdot \text{A}$$

$$P_{\text{RCL}} := 390 \cdot \text{W}$$

a) Below is a drawing the circuit model of one phase. Label **all** the parts and arrows and add known values.

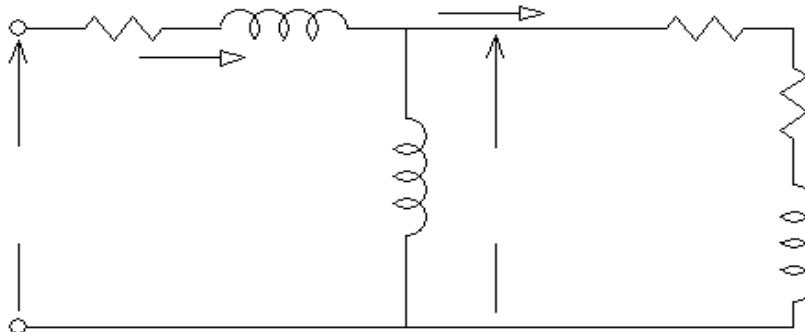

b) Find the slip. Make a reasonable assumption as necessary.

c) Find R_2

d) Find X_2

e) The magnitude of the line current. I advise you to assume the phase angle of \mathbf{E}_1 is 0° .

f) The air-gap power

h) Find the mechanical power losses (all lumped together).

_____ / 28

3. (20 pts) A one-line, per-phase diagram is shown below. Using the S_{base} given, draw a per-phase, per-unit diagram. Include pu values for **all** the values given in the drawing below. E_A voltage is line-to-neutral.

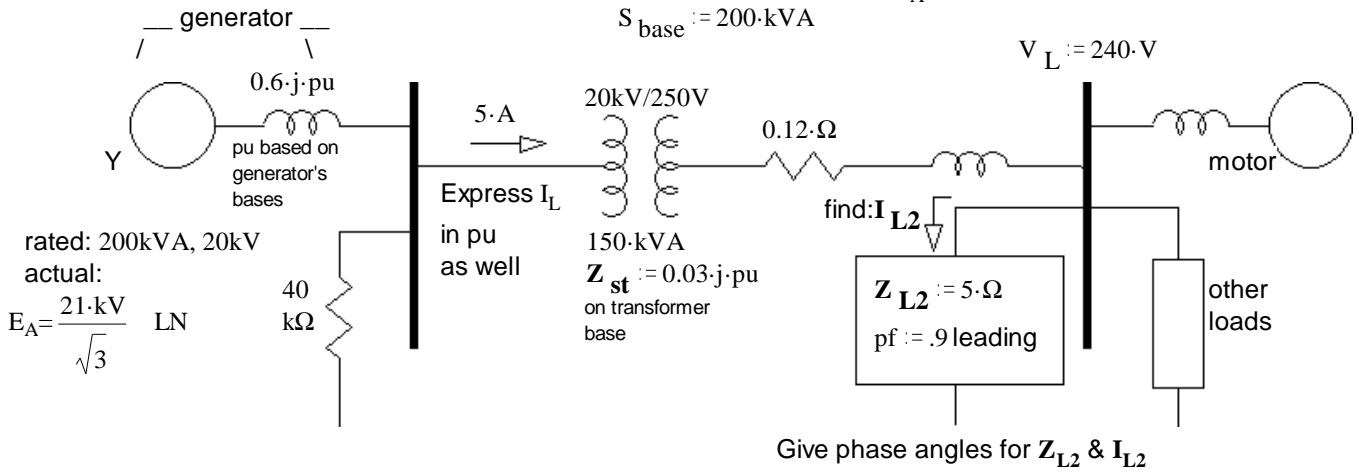

_____ / 20

Total _____ / 100

Answers

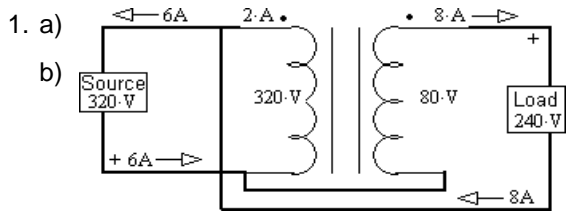

1. a) 1.92-kVA
 b) Source 320-V, Load 240-V, 320-W
 c) yes

2. a) 0° b) $\pm 30^\circ$ c) $\pm 30^\circ$ d) 0°
 e) yes Δ , to provide a path for the third-harmonic currents.

3. a) OC or Open-Circuit P, V, I
 $V = 500\text{-V}$ R_m X_m

3. b) SC or Short-Circuit P, V, I
 $I = \frac{1500 \cdot \text{VA}}{500\text{-V}} = 3\text{-A}$ R_s X_s

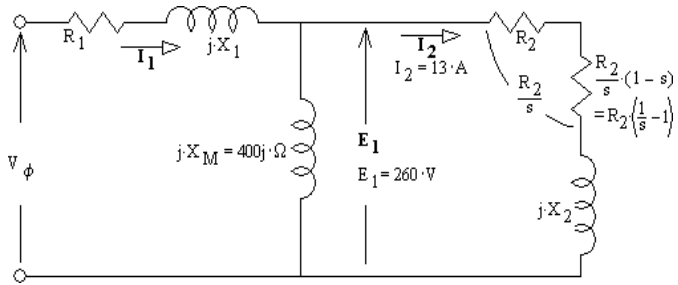

Problems

1. a) $\delta = 0\text{-deg}$ 0-W b) 26.15- Ω
 c) -18.7-kVAR d) 150.8-kW
 e) 18.44-deg f) -43.2-kVAR
 g) 2221-V h) 22.2-A i) decreased

2. b) 4-% c) 0.769- Ω d) 5.49- Ω e) 13.2-A f) 9.75-kW
 g) 9.36-kW h) 312.2-W

