

ECE 3600 Exam 1 given: Fall 23

DO NOT use erasable ink

1. (34 pts) R, L, & C together are the load (in dotted box). The power used by the load is $P_{\text{Load}} := 726 \text{ W}$. Find:

a) The magnitude of the resistor current.

$$|\mathbf{I}_R| = ?$$

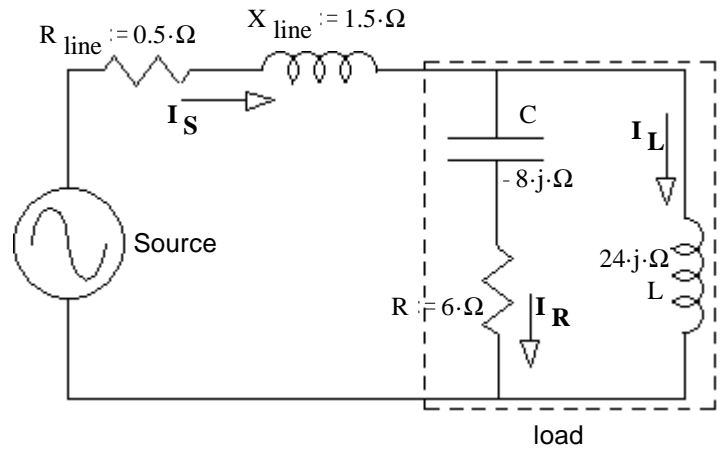

b) The voltage at the load (magnitude). $V_{\text{Load}} = ?$

c) The reactive power used by the load. $Q = ?$

d) The apparent power of the load. $|\mathbf{S}| = S = ?$

e) The power factor of the load. $\text{pf} = ?$

f) This power factor is: i) leading ii) lagging
(circle one)

1, continued g) The magnitudes of the other currents.

$$|\mathbf{I}_L| = ?$$

$$|\mathbf{I}_S| = ?$$

ECE 3600 Exam 1 Fall 23 p2

h) The source voltage (magnitude). $V_S = ?$

i) Is there something weird about this voltage? If so, what?

j) Why?

2. (24 pts) A one-line drawing of a 3-phase system is shown. Some 3-phase Ps and Qs are also shown. The 3-phase transformer is made of 3 individual single-phase transformers, each with a 2:1 turns ratio. Consider them to be ideal. They are hooked up Y - Y step-down so that the voltages on the left are twice the voltages on the right. Remember that bus and line voltages are the same. a) Find the complex power consumed by load 1.

Hints: Work from load 2 back and if you don't use Ps and Qs to solve this problem it will be VERY HARD!

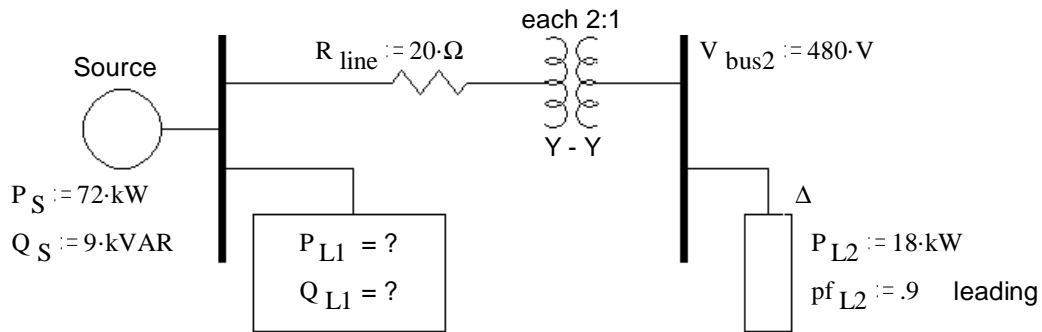

2. continued b) What is the efficiency of this system? $\eta = ?$

ECE 3600 Exam 1 Fall 23 p3

_____ / 24

3. This problem refers to the one-line drawing of problem 2, but does not require you to have answered problem 2

- a) Draw a full three-phase drawing of load L2. Assume the load is connected in Δ . Draw all three phases of the load and the connections to the three lines (A, B, & C). Find the values of the parts that you draw. (Actual component values, or reactances.)

$$\omega = 377 \cdot \frac{\text{rad}}{\text{sec}}$$

Note: There are two right answers to this problem, just find one.

- b) Add Y-connected components to your drawing above in order to correct the power factor in a balanced way. Find the values or reactances of the components. You may neglect any possible change in the 480-V bus voltage.

4. (27 pts) A model of a step-down transformer is shown below. The transformer is loaded with $\mathbf{Z}_L := (3 + 2j) \cdot \Omega$
- a) Find the current from the source, including complex part or phase angle. $\mathbf{I}_S = ?$ Use 3 for the turns ratio in the model: $N := 3$
 Note: You will need to make complex number calculations.

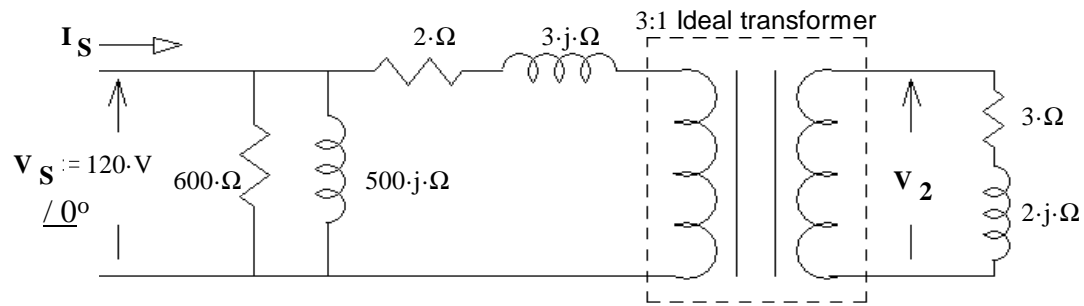

- b) Find the secondary voltage. Magnitude only. $|\mathbf{V}_2| = ?$

c) If this load were considered "full load", find the voltage regulation as defined in your notes. %VR = ?

d) Find the efficiency of the transformer.

Prob 4 _____ / 27

Answers

1. a) 11·A b) 110·V c) -463.8·VAR d) 861.5·VA e) 0.843

Total _____ / 100

f) Leading, capacitor dominates g) 4.583·A 7.832·A h) 107.6·V i) V_{ζ} is less than V_{Load}
 j) Partial resonance between the inductance in the line and the capacitance of the load.

OR Because the Q of the line partially cancels the Q of the load

2. a) $45.3 + j \cdot 17.7$ kVA b) 87.9·%

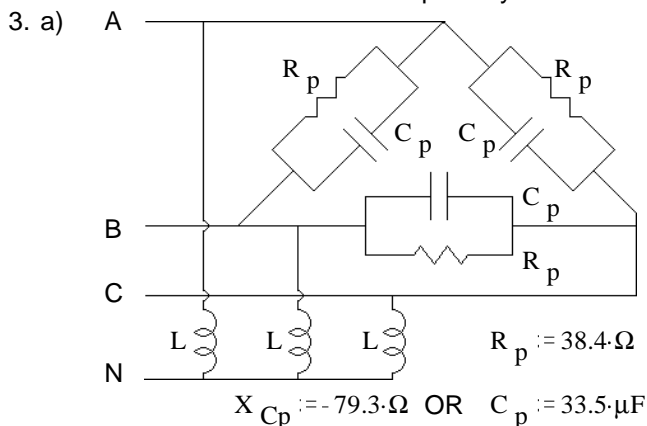

OR

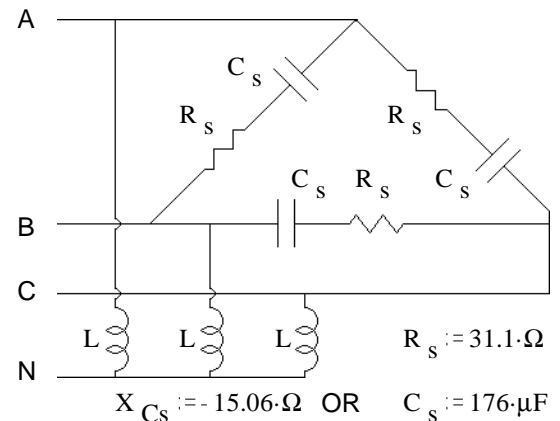

4. a) $(2.915 - 2.206 \cdot j) \cdot A$ b) 36.25·V c) 10.34·%

d) 44.82·%