

(14 pts) Questions This part of the exam is **Closed book, Closed notes, No Calculator.**

**Write Legibly!** If I can't read what you've written or your answer is ambiguous, I'll assume you don't know.

1. Express the power factor using the following: P and Q

2. a) Name the common curve shown at right.

b) Label the vertical and horizontal axes with the correct letters. Alternatively, you may indicate which axis is related to voltage and which is related to current by labeling with:

$$N \cdot I \quad \text{and} \quad V = N \cdot \frac{d\phi}{dt}$$

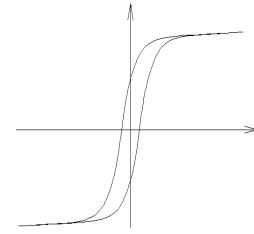

c) Many electrical devices we study contain a something which is characterized by this curve. What is that?

d) Name at least 2 issues caused by this part having this characteristic curve.

3. When accounting for the non-ideal characteristics of a power transformer, which of the following is the most important (least often neglected)?

- magnetization reactance      core losses      winding losses      leakage reactance

4. The voltage regulation of a transformer is often specified as %VR. Of the four values given below, circle the best %VR that could be a specification for a transformer.

- a) 2%      b) 50%      c) 98%      d) 120%

**The following problems were handed out to the student after finishing the closed-book part.**

This part of the exam is open book, open notes. You MUST show work to get credit. Show the correct units for each value. Assume voltage and current values are RMS and  $f := 60\text{-Hz}$ . Assume normal abc sequence and balanced conditions for all  $3\phi$ .

1. (30 pts) R, L, & C together are the load (in dotted box). The power used by the load is  $P_{\text{Load}} := 726\text{-W}$  Find:

a) The reactive power used by the load.  $Q = ?$

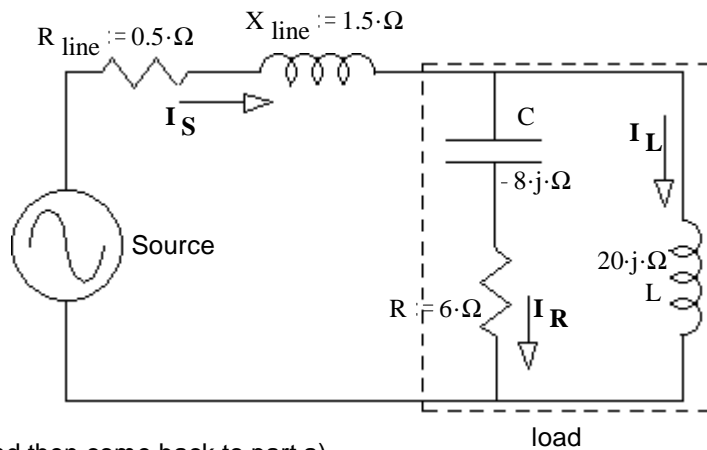

If you can't find this Q, try parts e) and f) first and then come back to part a).

b) The apparent power of the load.  $|S| = S = ?$

c) The power factor of the load.  $\text{pf} = ?$

d) This power factor is: i) leading ii) lagging (circle one)

e) The voltage at the load (magnitude).  $V_{\text{Load}} = ?$

f) The magnitudes of the three currents.  $|I_R| = ?$        $|I_L| = ?$        $|I_S| = ?$

g) The source voltage (magnitude).  $V_S = ?$

h) Is there something weird about this voltage? If so, what?

Why? (extra credit)

**ECE 3600 Exam 1 Fall 15 p2**

2. (22 pts) A one-line drawing of a 3-phase system is shown. Some 3-phase Ps and Qs are also shown. The 3-phase transformer is made of 3 individual single-phase transformers, each with a 2:1 turns ratio. Consider them to be ideal. They are hooked up Y - Y step-down so that the voltages on the left are twice the voltages on the right. Remember that bus and line voltages are the same. a) Find the complex power consumed by load 1.

Hints: Work from load 2 back and if you don't use Ps and Qs to solve this problem it will be VERY HARD!

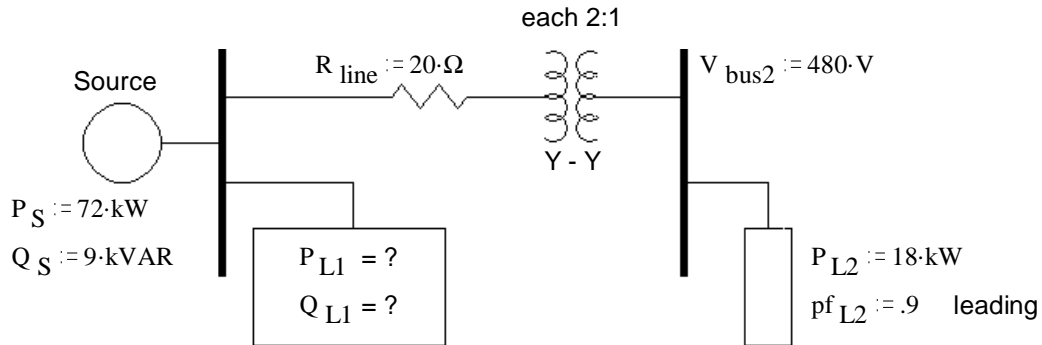

b) What is the efficiency of this system?  $\eta = ?$

3. (20 pts) The transformer shown in the circuit below is ideal. It is rated at 300/100 V, 1.2 kVA, 60 Hz

All values are RMS unless specified otherwise.

Find the following:

a) The primary current (magnitude).  $|I_1| = ?$

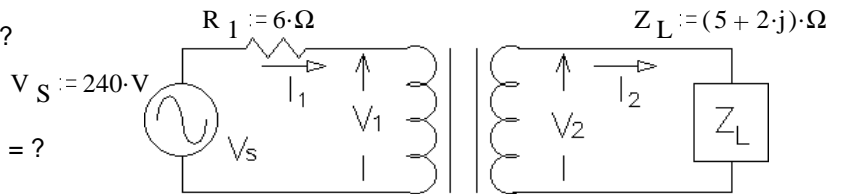

b) The secondary current (magnitude).  $|I_2| = ?$

c) The secondary voltage (magnitude).  $|V_2| = ?$

d) The complex power (P and Q) used by the load.  $S_L = ?$

e) Is this transformer operating within its ratings? Show your evidence.

4. (14 pts) A step-down transformer is rated at 300/100 V, 1.2 kVA, 60 Hz

The parameters below were obtained from testing the transformer in the usual ways, making the normal simplifications.

$$R_m := 1.6 \cdot k\Omega \quad R_s := 3 \cdot \Omega \quad X_m := 1 \cdot k\Omega \quad X_s := 6 \cdot \Omega$$

a) What was measured during the short-circuit test on this transformer? Give me values.

b) What was measured during the open-circuit test on this transformer? Give me values.

**Answers**

**Closed-book part** 1.  $pf = \frac{P}{\sqrt{P^2 + Q^2}}$  OR  $pf = \cos\left(\text{atan}\left(\frac{Q}{P}\right)\right)$

2. a) B-H curve or Hysteresis curve b) x-axis: H or N·I y-axis: B or  $V = N \cdot \frac{d}{dt} \phi$  c) The core

d) Core losses Nonlinearities, esp. in the currents 3rd harmonic currents  
Sets voltage limits requires more windings so that the core flux can be less  
Requires larger, heavier cores

2 of these

3. leakage reactance 4. a)

**Open-book part** 1. a) -363·VAR b) 812·VA c) 0.894 d) j) e) 110·V f) 11·A 5.5·A 7.38·A

g) 109·V h)  $V_S$  is less than  $V_{Load}$  Because the Q of the line partially cancels the Q of the load

2. a) 45.3 + j·17.7 kVA b) 87.9·%

3. a) 4.44·A b) 13.3·A c) 71.7·V d) 886 + j·354 VA e) NO, currents are too high

4. a) 48·W 26.8·V b) 56.3·W 354·mA