

ECE 3600 Exam 2 given: Fall 10

(The space between problems has been removed.)

Write Legibly! This part of the exam is **Closed book, Closed notes, No Calculator.**

(27 pts) Questions If I can't read what you've written or you answer is ambiguous, I'll assume you don't know.

1. a) A 3-phase step-up transformer is usually wired in what way? Y - Y Y - Δ Δ - Y Δ - Δ
circle one
- b) A 3-phase step-down transformer is usually wired in what way? Y - Y Y - Δ Δ - Y Δ - Δ
circle one
- c) Is it desirable for at least one side of a 3-phase transformer to be wired in a certain way? yes no
If yes, which way and why? circle one

2. You have a 100/250-V, 500-VA transformer.
Can you use this transformer to transform 350 V to 100 V? If yes, show the connections and compute the new VA rating.

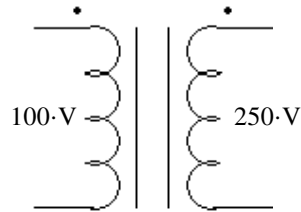

3. You have a 100/250-V, 500-VA transformer.
a) Can you use this transformer to transform 80 V to 120 V? If yes, show the connections and compute the maximum power that can be transformed at these voltages.

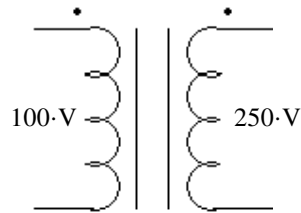

- b) What condition must be met by the load to transform this maximum power?
4. When accounting for the non-ideal characteristics of a power transformer, which of the following is the most important (least often neglected)?
- circle one
- magnetization reactance core losses winding losses leakage reactance
5. a) Consider a 3-phase synchronous-machine phasor diagram. To increase the real output power (watts), what is the primary thing that should change? (All other changes in the phasor diagram will follow from this change.) Say what should change and whether it should increase or decrease.
- b) As a power plant operator, how do you make that happen?
6. a) Consider a 3-phase synchronous-machine phasor diagram. To increase the reactive output power (VARs), what is the primary thing that should change? (All other changes in the phasor diagram will follow from this change.) Say what should change and whether it should increase or decrease.
- b) As a power plant operator, how do you make that happen?

7. A motor is rated at 15hp, 480V, 60Hz, 860rpm.
a) What type of motor is this (most likely).
b) How many poles does it have?
c) What is the full-load slip of this motor?

ECE 3600 Exam #2 Arn Stolp
Scores:
Pages 1&2 _____ of a possible 23 pts
Pages 3&4 _____ of a possible 50 pts
Questions _____ of a possible 27 pts
Total _____ of a possible 100 pts

This part of the exam is open book, open notes.
 You **MUST** show work to get credit. Show the correct units

1. (23 pts) You make the following measurements on a 3-phase, Y-connected, synchronous generator.

$$P_{3\phi} := 150\text{-kW} \quad V_{LL} := 480\text{-V} \quad I_L := 195\text{-A} \quad X_s := 0.9\text{-}\Omega$$

Unfortunately, you don't know the phase angle of current.

a) Draw a phasor diagram of one of the two possible interpretations of these numbers.
 Find the induced armature voltage (E_A) and the power angle, δ . $E_A = ?$ $\delta = ?$

b) Draw a phasor diagram of other possible interpretation of these numbers.
 Find the induced armature voltage (E_A) and the power angle, δ . $E_A = ?$ $\delta = ?$

c) A traveling carnival uses a combination of this generator and the local power company to run its load, mainly induction motors. When the generator is connected to the carnival's power distribution network, it supplies half of the required power, but the current from the power company only decreases by about 30%. Which of the calculations above is most likely correct?

d) What do you change at the generator to reduce the current flow from the power company?
 Tell me what you adjust and if you turn it up or down.

2. (22 pts) A one-line, per-phase diagram is shown below. Using the S_{base} given, draw a per-phase, per-unit diagram. Include pu values for **all** the values given in the drawing below. All voltages are line-to-neutral.

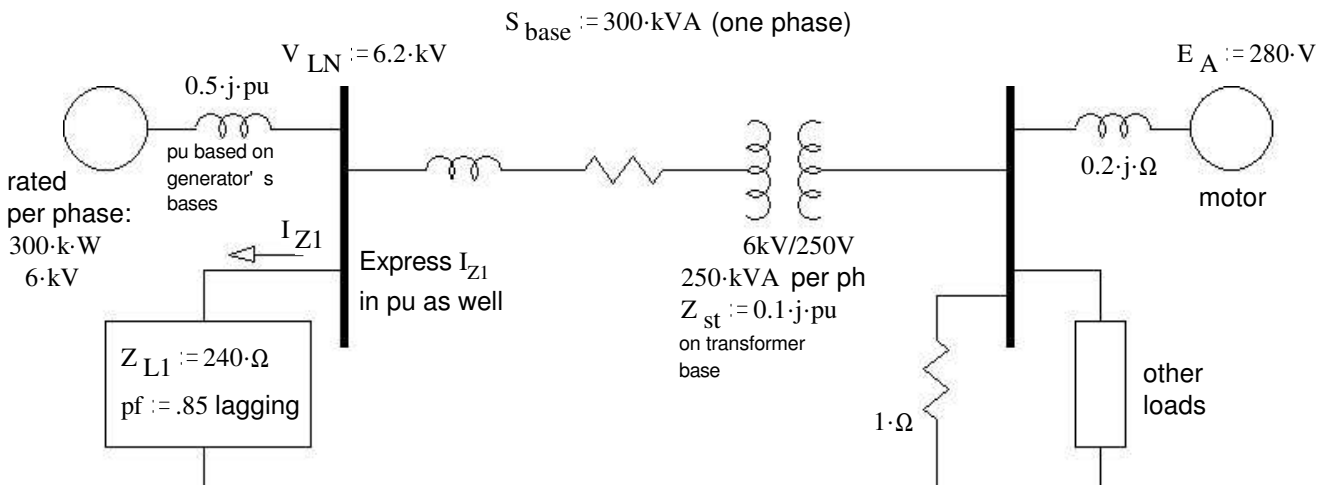

Give phase angle for both Z_{L1} and I_{Z1}

3. (28 pts) A 3-phase, Y-connected, induction motor has the following equivalent circuit components:

$$R_1 := 0.2\text{-}\Omega \quad R_2 := 0.13\text{-}\Omega \quad R_C := \infty \quad \text{currently running at } n := 3500\text{-rpm}$$

$$X_1 := 0.3\text{-}\Omega \quad X_2 := 0.45\text{-}\Omega \quad X_M := 12\text{-}\Omega \quad P_{AG} := 7.5\text{-kW}$$

- a) Find $|I_2|$ Note: Use the P_{AG} for one phase, the slip and R_2 .
- b) Find P_{RCL}
- c) The output shaft torque is $\tau_{load} := 19\text{-N}\cdot\text{m}$ Find the output power
- d) Find the mechanical power losses (all lumped together).
- e) Find the line current. Note: Don't try any shortcuts here. You need to do your math with full complex numbers.
 $|I_L| = ?$ I advise you to assume the phase angle of I_2 is 0° .
- f) The stator copper losses P_{SCL}
- g) The overall machine efficiency η

Answers

Questions

1. a) ($\Delta - Y$) b) ($Y - \Delta$) c) (yes)

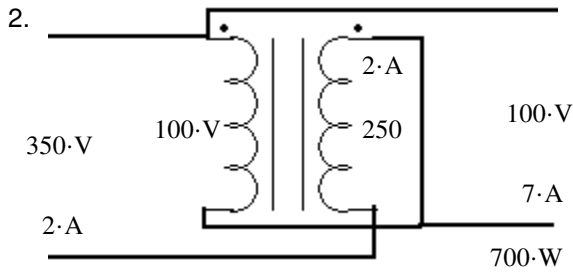

Δ , to reduce third-harmonic currents.

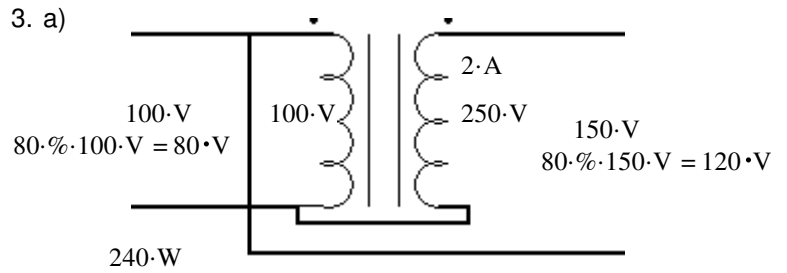

b) $pf = 1$ OR $Z_L = \frac{120 \cdot V}{2 \cdot A} = 60 \cdot \Omega$ purely resistive

4. (leakage reactance)

5. a) Increase the power or torque angle, δ

- b) Increase the mechanical input power

6. a) Increase E_{af} (E_A).

- b) Increase the field or rotor current

7. a) 3-phase induction motor

- b) 8 poles

- c) 4.44%

Problems

1. a) & b) could be in either order

a) If I_L leads V_ϕ 266·V 37.6·deg

b) If V_ϕ leads I_L 380·V 25.3·deg

c) I_L leads V_ϕ The induction motors represent a lagging pf load, they use lots of VARs. If the local generator were supplying those VARs, then the current would go down by about half and quite possibly more. The small reduction in current implies that the generator also consumes VARs (creates negative VARs). That is condition a).

- d) Turn up the field current.

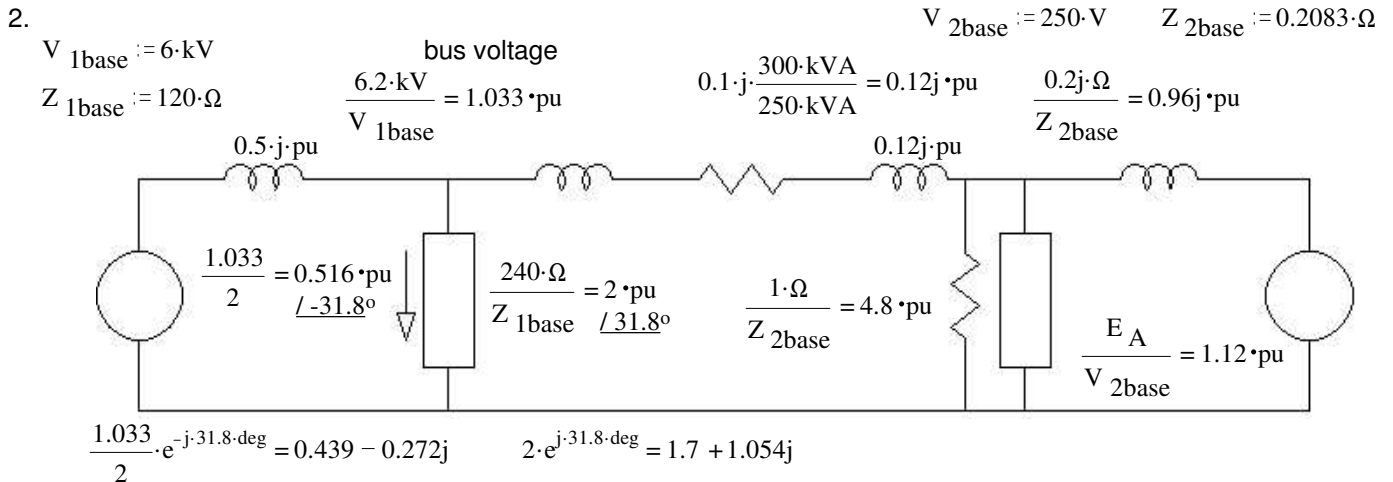

3. a) 23.1·A b) 208·W c) 6.96·kW d) 328W e) 25.6·A f) 394·W g) 88.2%

Study guide for exam 2

Homework 8 - Ind2

Labs 2 & 3

Field trip to Rocky Mountain Power Dispatch Center

Subjects

Non-ideal and Auto-transformers. OC and SC tests

per-unit, per-phase

Synchronous motors and generators

3-phase induction motors