

ECE 3600 Exam 1 given: Fall 09

(The space between problems has been removed.)

Write Legibly! This part of the exam is **Closed book, Closed notes, No Calculator.**

(22 pts) Questions If I can't read what you've written or your answer is ambiguous, I'll assume you don't know.

- Give the two largest sources of energy used to produce electricity in the US. List the largest first.
 -
 -
- Give the approximate efficiencies of each type of power plant:
 - Hydroelectric
 - Rankin-cycle steam turbine plants, regardless of the source of heat. (coal, oil, gas-steam, nuclear, solar-steam, geothermal)
 - Single-cycle gas turbine
 - Combined-cycle gas turbine
- What does it mean when a 3-phase system is "balanced"?
- When accounting for the non-ideal characteristics of a power transformer, which of the following has effects that depend on the transformer loading (currents)? Circle as many as you want:

magnetization reactance core losses winding losses leakage reactance
- A single-phase transformer is rated at 2400 VA, 1200/240 V . The transformer is operated at its rated voltages.
 - What is the rated current in the primary?
 - What is the rated current in the secondary?
 - How are these ratings affected if the transformer is operated at half the rated voltages?
 - What is the turns ratio of this transformer?
 - A resistor, R_L , hooked to the secondary of this transformer would appear how big from the primary side?

The following problems were handed out to the student after finishing the closed-book part.

This part of the exam is open book, open notes. You MUST show work to get credit. Show the correct units for each value. Assume $f := 60\text{-Hz}$ for all problems and normal abc sequence for all 3 ϕ

- (15 pts) For the 60 Hz load shown in the figure, the RMS voltmeter measures 220 V, the wattmeter measures 560 W, and the power factor is 82%. Find the following:

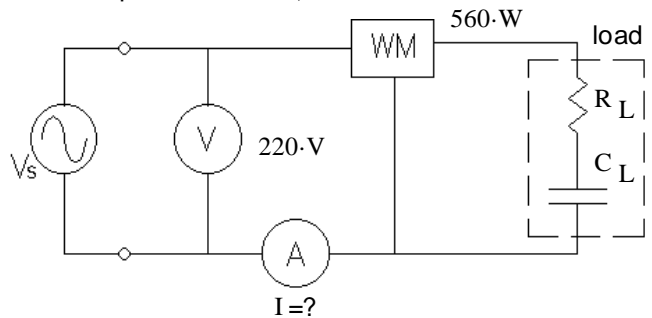

- The reading on the RMS ammeter.
- The apparent power. $|S| = ?$
- The reactive power. $Q = ?$
- The complex power. $S = ?$
- The value of the load capacitor. $C_L = ?$
- The power factor is: i) leading ii) lagging (circle one)

- (15 pts) An electric motor is hooked to a 240-V, 60-Hz source.

The motor draws the following complex power.

$$S := (900 + 600j) \cdot \text{VA}$$

- Add (draw it) a component to the drawing which can correct the power factor (make $\text{pf} = 1$). Show the correct component in the correct place and find its value. This component should not affect the mechanical power output of the motor.

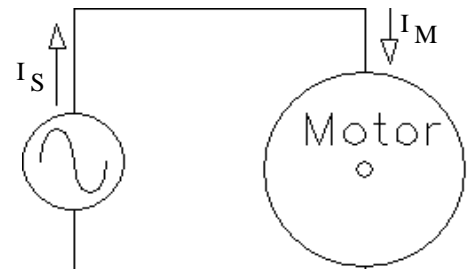

b) Is the source current $|I_S|$ the same as the motor current $|I_M|$ now that the component of part a) is added?

If not, which is greater and by how much?

c) If you could not find the part you specified for part a) and used one that was 20% too big, then:

- i) The **actual** source current $|I_S|$ is **greater** than that calculated in part b).
- ii) The **actual** source current $|I_S|$ is **the same** as that calculated in part b).
- iii) The **actual** source current $|I_S|$ is **less** than that calculated in part b).

circle one

3. (15 pts) a) A 3-phase system delivers 380-V, 3-phase power of 12 kW to a load with a 70% power factor. Each line has a resistance of 0.5 Ω. Find the total power lost in the lines and the overall efficiency of the system.

b) The power factor is corrected and the source voltage is adjusted so that it still delivers 380-V, 3-phase power of 12 kW to a load. What is the new efficiency?

4. (16 pts) Find the following: Hint: Convert to Y & redraw one phase of the system.

- a) The line current that would be measured by an ammeter. Hint: Convert to Y
- b) The power factor of the load. Don't include the lines.
- c) The power consumed by the three-phase load. Don't include power lost in the lines.
- d) What is the line voltage at the load? Just magnitude.

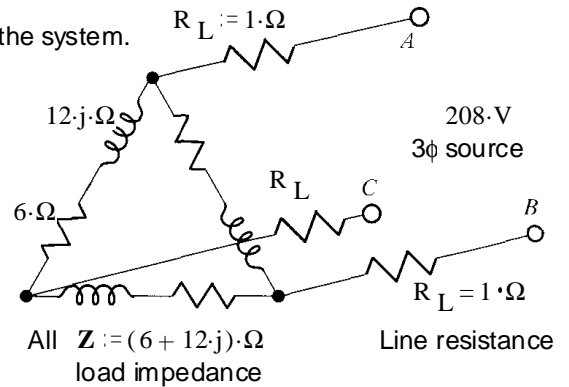

5. (17 pts) A model of a 3:1 step-down transformer is shown below. The transformer is loaded with $Z_L := (3 + 2 \cdot j) \cdot \Omega$.

a) Find the current from the source, including complex part or phase angle. $I_S = ?$

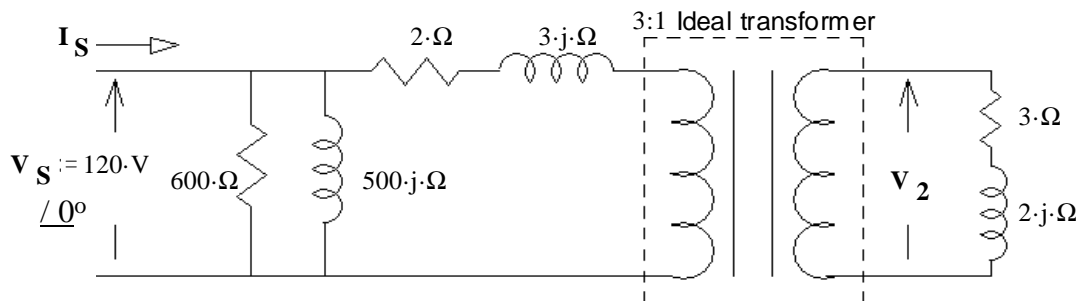

b) Find the secondary voltage. Magnitude only. $|V_2| = ?$

Answers

Closed-book part

- 1. 1. Coal 2. Nuclear or 2. Natural Gas (Natural gas is now #2, not nuclear)
- 2. a) $\geq 90\%$ b) 35 - 40% c) $\sim 38\%$ d) 55 - 60%
- 3. The 3 voltages are equal, the 3 currents are equal and the 3 loads are equal.
- 4. winding losses leakage reactance
- 5. a) 2·A b) 10·A c) NOT affected d) 5 e) $25 \cdot R_L$ 25 times bigger

Open-book part

- 1. a) 3.10·A b) 683·VA c) -391·VAR d) $(560 - 391 \cdot j) \cdot VA$ f) 65.4·μF e) i) leading
- 2. a) 27.6·μF b) I_M greater by 0.757·A c) i)
- 3. a) 92.2·% b) 96.0·% 4. a) 24.0·A b) 0.447 c) 3.46·kW d) 186·V
- 5. a) $(2.915 - 2.206 \cdot j) \cdot A$ b) 36.25·V

(The space between problems has been removed.)

