

"Protection" almost always refers to the protection of power company equipment and lines and reducing fire risks, not the protection humans, animals, or the environment. Most protection devices are used to detect or interrupt undesirable currents. These could be currents which are too high (over-currents) and/or flowing where they shouldn't be (short circuits). Over-voltage problems are actually more common, but they are handled in a relatively simple way.

- Requirements
1. Reliability (Fully protect all the equipment from every fault)
 2. Speed
 3. Selectivity (don't trip when there really isn't a fault)
 4. Simplicity
 5. Minimize Customer Impact

Over-Voltage Protection

Surge & Lightning Arresters are highly nonlinear devices which have a high resistance at normal voltages and low resistance at voltages over their threshold. They protect transformers and other devices from over-voltages.

Almost all over-voltage events are caused by lightning, but a few are the results of transients caused by faults or switching, esp. breakers tripping.



(Megger.com)

People Protection Devices

Disconnect Switches It is common to find large, open-air switching devices in substations. It should be easy to see when they are open and they cannot be closed remotely. They are NOT used to open or close energized circuits. The purpose of these switches is to allow linemen working on the equipment, busses, and lines in the yard to visually confirm that items are de-energized.



(saVRee)

See giphy.gif on the website for a short video of opening these type of switches. The arcing is due to voltages present due to capacitive coupling between lines.



(Wikipedia)

GFCI (Ground-Fault Circuit Interrupter) devices are placed where end-users are exposed to electrical power. A GFCI compares the current flowing out the "hot" connection with the return current in the neutral connection. They trip when a difference between these two currents indicate some current has found another path to ground, possibly through a person.



GFCI Outlet

GFCI Breaker

(Amazon)

Current Protection

Breakers

Breakers used in your home are self-contained in that they sense a current problem and "trip" all by themselves. (A breaker "trips" by opening the connection.) Most of the breakers used in commercial installations are also self-contained, although some have more complex time and current settings.

Power companies also use self contained breakers and reclosure devices in the lowest-voltage distribution substations, but, above that, almost all of their breakers are just large remote-control switches. They are controlled by relays housed in the substation buildings or commands sent by operators.

Large breakers come in two types. Oil-filled breakers are mostly phased out now in favor of gas filled. Both oil and SF₆ gas are very good insulators, but it's much easier to move the contacts in the gas than the oil, especially when it's cold. Some SF₆ breakers can open in as little as 2 cycles (1/30th of a second). Both types use stored mechanical energy to move the contacts, typically spring-loaded or high-pressure air. They can open and close several times even when the substation power is down.

Breakers use a variety of methods to blow out or extinguish the arc that occurs when the contacts open.



Oil-filled Older, slower style (Arn)



SF₆ gas-filled Newer (Arn)

Fuses

Local distribution lines are usually protected by fuses rather than expensive breakers or reclosure devices.

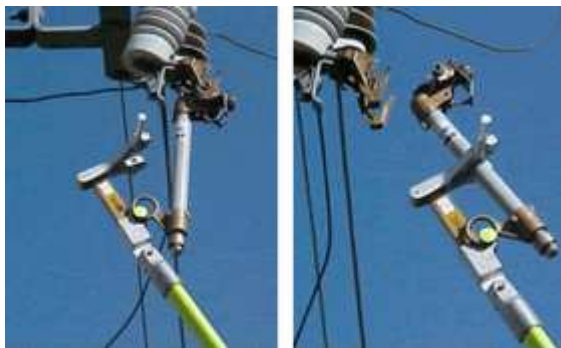

Fuses can be replaced from the ground.

(Hastings)



Instrument Transformers

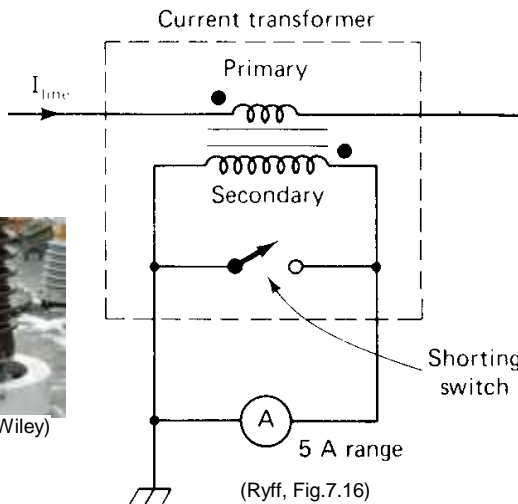

(IET Wiley)

CT

The secondary **must** always be shorted or nearly shorted!

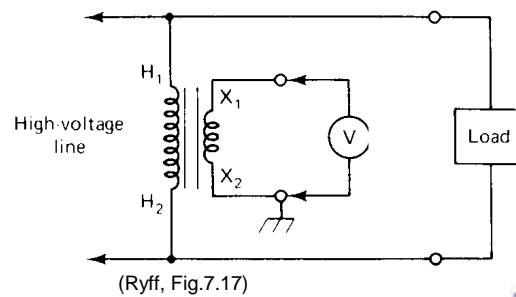

"Potential" transformer, for voltage monitoring

VT or PT



base grounded (powerlinedelhi)

Many newer PTs are actually voltage dividers, not transformers.

ECE 3600 Protection notes p3

Relays

Relays are the brains. They take information from the CTs and VTs and trip the breakers when they detect a fault. Conversely, they should "block" (not trip) when there isn't a fault, even during over-current conditions like transformer inrush currents.



Digital Relays (wikitestguy)



Electromechanical Relay (Arn)



Digital Relays (Arn)

Over-Current Relay

Some of these relays immediately trip when any over-current is detected, but more commonly, they include some time delay to allow a breaker closer to the fault to trip first. A sample time-delay curve is shown here.

This particular relay has 11 different settings, that's why there are so many different curves.

Time (Seconds)

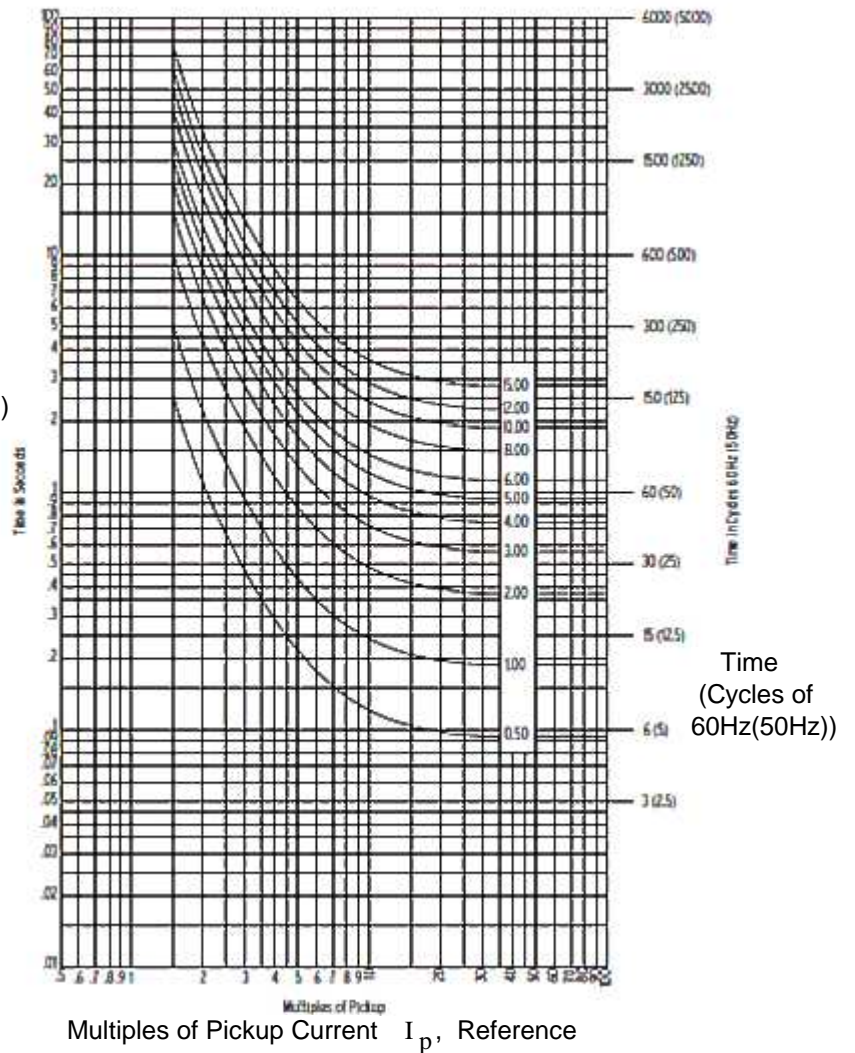

Directional Relay

In addition to detecting over-currents, a directional relay uses phase differences between the voltage and current to determine where the fault is relative to the measuring location. They will only trip for faults on one side of the relay and not the other. They are useful for lines which could carry power in either direction.

Distance (Impedance) Relay

A distance relay is used for transmission lines. It uses voltage and current measurements to determine an impedance. Since a transmission line's impedance increases with distance, the impedance can indicate the distance to the fault. They will only trip if the impedance is within a specified region on the complex plane.

Differential Relay

A differential relay monitors the currents flowing into and out of some device or bus. A difference indicates a current "leak" and the relay will trip breakers to isolate the region with the undesired current.

Pilot Relay

A pilot relay is a type of differential relay used for transmission lines. It uses one or more communication systems to exchange information with it's counterpart at the other end of the transmission line.

Protection Strategy

Minimize Customer Impact. Make sure that the breaker closest to the actual fault trips first, thus preventing other trips and minimizing the region of power outage. This is where the current / time curves for time-delay relays are used.

Relay Coordination is the process to make this happen, no matter where the fault may be. The curves at right are used to coordinate relays and breakers.

Zones of Protection are used for a similar purpose, to isolate the fault into the smallest possible region.

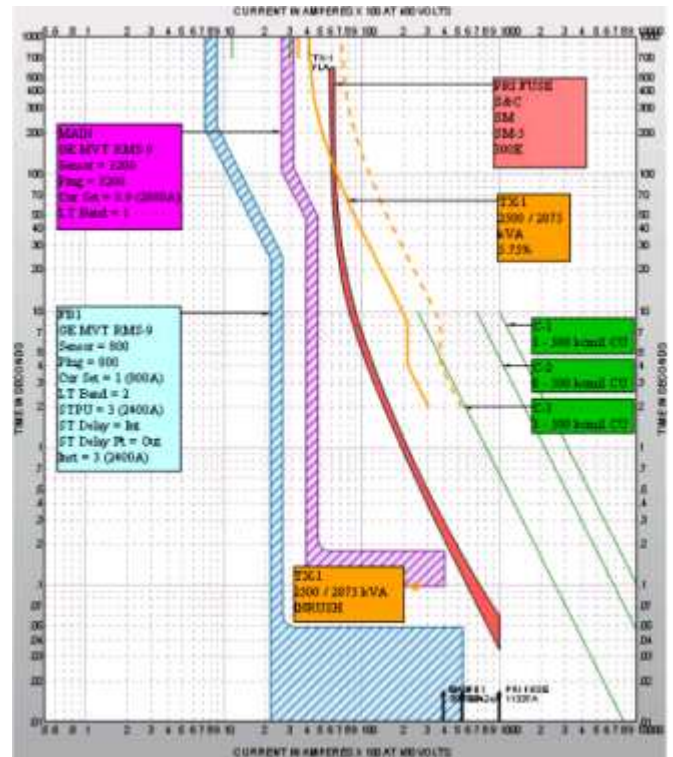

(EasyPower)



The battery room at Terminal substation (Am)

DC Power and Battery Backup

Relays, breakers and communication equipment work on DC power so that battery backups can keep them working even if there's a power outage. Or, rather, *especially* if there's a power outage.

Communications

The power company likes to maintain at least 3 separate, redundant, communication systems across their grid. Typically: Fiber optics, wireless microwave, and wired telecommunications. They keep separate from the internet for security reasons.

- More Information <https://wiki.testguy.net/t/protective-relay-testing-and-maintenance-overview/76>
- <https://www.easypower.com/resources/article/overcurrent-coordination-and-protection-basics>
- <https://www.mavtechglobal.com/pdf/white-papers/Time-Current-Curves-Whitepaper-2019.pdf>

Restoring Connections

Rigorous safety protocols must be met before breakers are switched back on.

If the breaker connects two regions with separate power generation, then operators may have to wait for the regions to synchronize, much like placing a generator on-line.

- Sources: [Power Systems Analysis and Design](#), Glover, Sarma & Overbye
- [Electric Power Systems, Schaum's Outline](#), Syed A. Nasar
- [First Course on Power Systems](#), Ned Mohan