

Requirements of the power system:

1. The power generation meets the demand. The net $P = 0$ and net $Q = 0$.
2. Bus voltages are within limits.
3. Generators operate within their real and reactive power limits.
4. Transformers and transmission lines are not overloaded.

Sensors placed around the network can let operators know if these requirements are being met. The sensors, the telemetry and the display of this information is called SCADA (Supervisory Control and Data Acquisition) system.

What if your sensors show that you are not meeting requirements? What do you change? What if you anticipate changes in the loads or the system? How do you prepare for that? You need a way to predict the effects of changes.

The Power-Flow Problem (sometimes called Load-Flow problem)

To predict how the system will respond to different situations you have to solve a complex problem involving many sources, transformers, transmission lines and loads, typically using nodal analysis where the buses are the nodes. This is a steady-state analysis.

A few assumptions and simplifications make the problem more tractable:

1. Assume a balanced 3-phase system so you can work with just one phase (per phase).
2. Work with per-unit values with a single S_{base} and V_{base} s such that the transformers become simple impedances.
3. Assume at least one bus is connected to the larger power grid and that this bus can supply whatever P and Q are needed to make up for whatever slack there may be locally. This is called the "Slack bus" or "Swing bus".

The voltage phase angle of this bus is taken to be the 0° reference.

4. Positive P , Q and I are into the local system. Negative goes the other way. Thus, generation results in positive P and I and loads result in negative P and I . Same for Q s that would normally be considered positive.

And a few assumptions of what you will know: (A **bus** is substation or generation site.)

5. **Generator bus** At buses where generators are connected and holding the voltage constant you will know the power, P , and the voltage, V . This type of bus is called a "Generator bus", a "Voltage controlled bus" or simply a "PV bus"

P is positive unless loads are also connected to this bus, then a load requirements greater than the generator output could make P and/or Q negative.

6. **Load bus** At buses where only loads are connected you will know the power, P_{load} , and the reactive power, Q_{load} , consumed by the load. This type of bus is called a "Load bus" or simply a "PQ bus". Power out of the system is considered negative, so: $P = -P_{load}$, $Q = -Q_{load}$.

At buses where only transmission lines and transformers are connected, $P = 0$ and $Q = 0$. This is considered a variation of a Load bus or PQ bus.

7. **Slack (or Swing) bus** This is the reference bus or a connection to a larger grid. Its voltage is the reference voltage (1 pu) and 0° phase. P and Q are unknown and adjust to make the overall P and Q of the system 0. Also called the Swing bus or "Infinite" bus.

8. All line and transformer characteristics.

The actual calculations use admittances (Y) rather than impedances. $Y = \frac{1}{Z}$

Each bus is a "node"

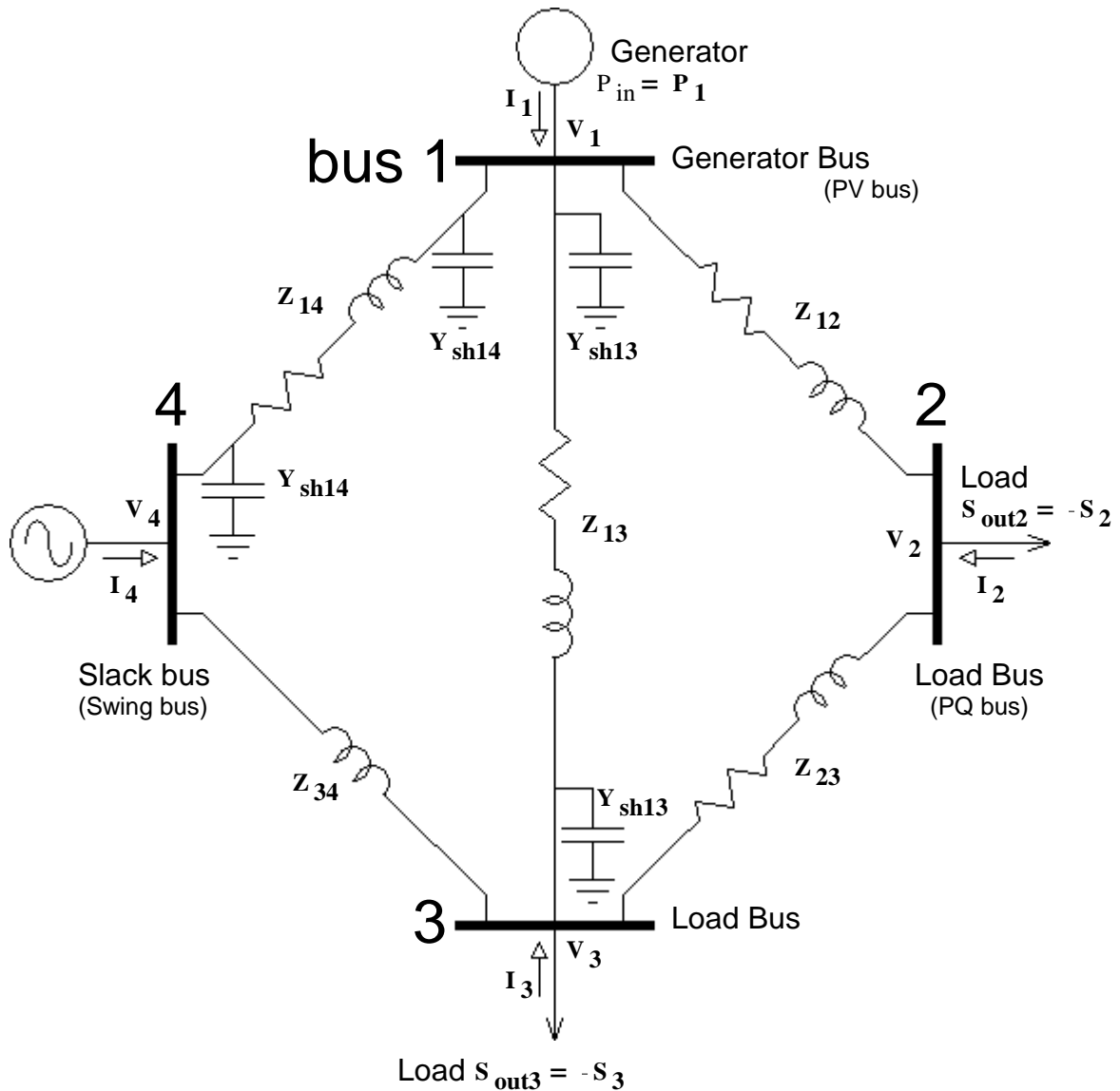

Admittance Matrix

$$\begin{bmatrix} I_1 \\ I_2 \\ I_3 \\ I_4 \end{bmatrix} = \begin{bmatrix} Y_{11} & Y_{12} & Y_{13} & Y_{14} \\ Y_{21} & Y_{22} & Y_{23} & Y_{24} \\ Y_{31} & Y_{32} & Y_{33} & Y_{34} \\ Y_{41} & Y_{42} & Y_{43} & Y_{44} \end{bmatrix} \begin{bmatrix} V_1 \\ V_2 \\ V_3 \\ V_4 \end{bmatrix}$$

Nodal analysis

Finding the admittance matrix is covered next and in section 10.3 (p.498) in your textbook.

ECE 3600 Power Flow notes p3

Looking at just bus 1:

From the matrix: $I_1 = V_1 \cdot Y_{11} + V_2 \cdot Y_{12} + V_3 \cdot Y_{13} + V_4 \cdot Y_{14}$

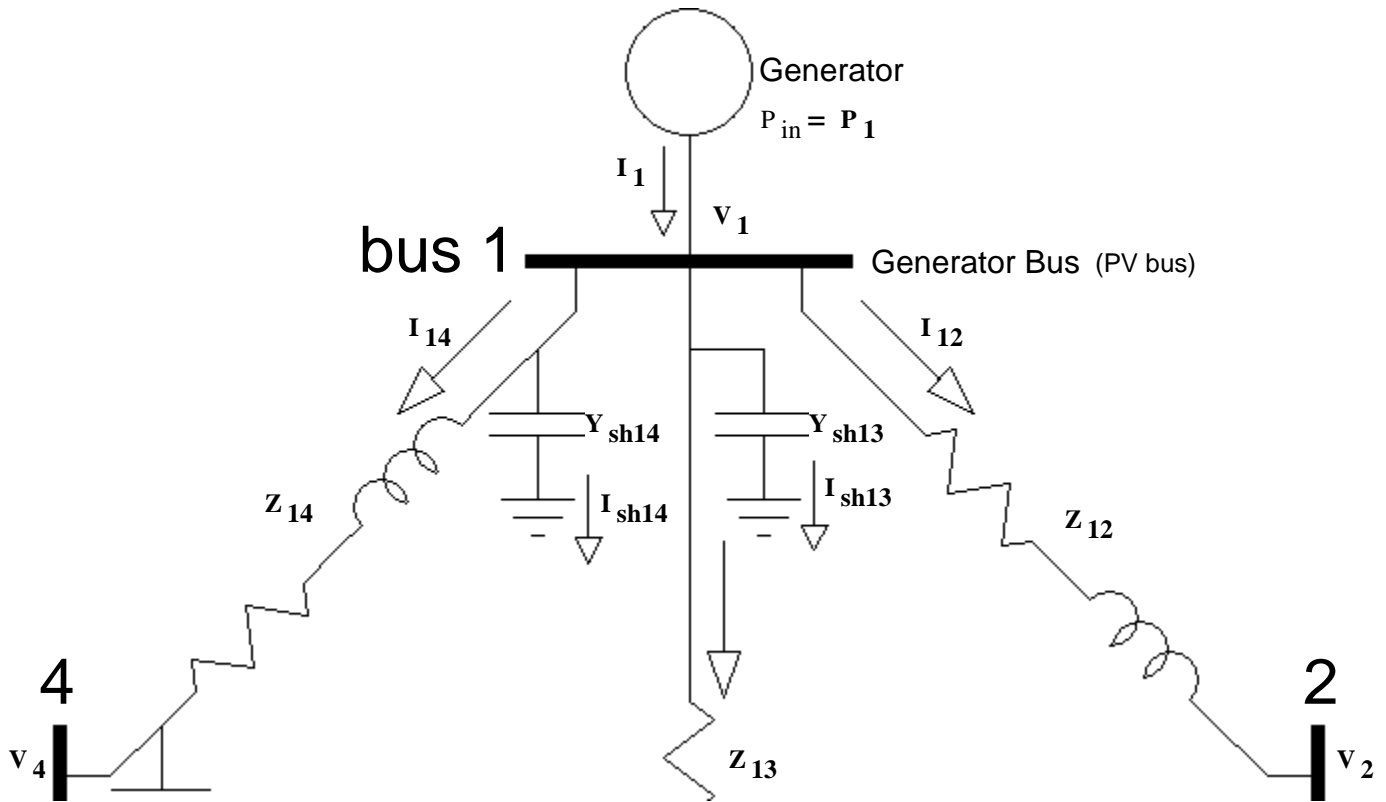

From the diagram:

$$I_1 = V_1 \cdot Y_{sh13} + V_1 \cdot Y_{sh14} + (V_1 - V_2) \cdot \frac{1}{Z_{12}} + (V_1 - V_3) \cdot \frac{1}{Z_{13}} + (V_1 - V_4) \cdot \frac{1}{Z_{14}}$$

$$= V_1 \cdot (Y_{sh13} + Y_{sh14}) + \frac{1}{Z_{12}} \cdot V_1 - \frac{1}{Z_{12}} \cdot V_2 + \frac{1}{Z_{13}} \cdot V_1 - \frac{1}{Z_{13}} \cdot V_3 + \frac{1}{Z_{14}} \cdot V_1 - \frac{1}{Z_{14}} \cdot V_4$$

$$= V_1 \cdot \left(Y_{sh13} + Y_{sh14} + \frac{1}{Z_{12}} + \frac{1}{Z_{13}} + \frac{1}{Z_{14}} \right) - \frac{1}{Z_{12}} \cdot V_2 - \frac{1}{Z_{13}} \cdot V_3 - \frac{1}{Z_{14}} \cdot V_4$$

$$= V_1 \cdot \left(Y_{sh13} + Y_{sh14} + \frac{1}{Z_{12}} + \frac{1}{Z_{13}} + \frac{1}{Z_{14}} \right) + V_2 \cdot \left(-\frac{1}{Z_{12}} \right) + V_3 \cdot \left(-\frac{1}{Z_{13}} \right) + V_4 \cdot \left(-\frac{1}{Z_{14}} \right)$$

From matrix: $I_1 = V_1 \cdot Y_{11} + V_2 \cdot Y_{12} + V_3 \cdot Y_{13} + V_4 \cdot Y_{14}$

$$Y_{11} = \left(Y_{sh13} + Y_{sh14} + \frac{1}{Z_{12}} + \frac{1}{Z_{13}} + \frac{1}{Z_{14}} \right)$$

= Σ of all admittances connected to bus 1

$$Y_{12} = \left(-\frac{1}{Z_{12}} \right) = - \text{admittance 12}$$

$$Y_{13} = \left(-\frac{1}{Z_{13}} \right)$$

$$Y_{14} = \left(-\frac{1}{Z_{14}} \right)$$

ECE 3600 Power Flow notes p4

Start with the voltages you know from the slack bus and any generator buses. Guess the rest to start.

Solve this with a computer:

$$\begin{bmatrix} I_1 \\ I_2 \\ I_3 \\ I_4 \end{bmatrix} = \begin{bmatrix} Y_{11} & Y_{12} & Y_{13} & Y_{14} \\ Y_{21} & Y_{22} & Y_{23} & Y_{24} \\ Y_{31} & Y_{32} & Y_{33} & Y_{34} \\ Y_{41} & Y_{42} & Y_{43} & Y_{44} \end{bmatrix} \begin{bmatrix} V_1 \\ V_2 \\ V_3 \\ V_4 \end{bmatrix}$$

To get all the unknown **I**s and **V**s.

Combine with power calculations:

Complex "power" $S = \mathbf{V} \cdot \overline{\mathbf{I}}$ = $P + jQ$ if P and Q are to be found

$\overline{\mathbf{I}} = \frac{P + jQ}{\mathbf{V}}$ OR $\mathbf{V} = \frac{P + jQ}{\overline{\mathbf{I}}}$ to get new values

$\mathbf{I} = \overline{\left(\frac{P + jQ}{\mathbf{V}} \right)} = \frac{P - jQ}{\overline{\mathbf{V}}}$ if P and Q are known

$$I_2 = V_1 \cdot Y_{21} + V_2 \cdot Y_{22} + V_3 \cdot Y_{23} + V_4 \cdot Y_{24} = \frac{P_2 - jQ_2}{\overline{V_2}} \text{ for a load bus}$$

$$V_2 = \frac{1}{Y_{22}} \cdot \left[\frac{P_2 - jQ_2}{\overline{V_2}} - (V_1 \cdot Y_{21} + V_3 \cdot Y_{23} + V_4 \cdot Y_{24}) \right]$$

for a generator bus $V_1 \cdot Y_{11} + V_2 \cdot Y_{12} + V_3 \cdot Y_{13} + V_4 \cdot Y_{14} = \frac{P_1 - jQ_1}{\overline{V_1}}$

$$Q_1 = -\text{Im} \left[\overline{V_1} \cdot (V_1 \cdot Y_{11} + V_2 \cdot Y_{12} + V_3 \cdot Y_{13} + V_4 \cdot Y_{14}) \right]$$

To get new values

These problems are solved by computers using iterative, numerical methods, like the Newton-Raphson or the Gauss-Siedel method. They may require a starting guess and may not always converge to a solution.

The line currents can be found from:

$$I_{L12} = \frac{V_1 - V_2}{Z_{\text{series}12}} = (V_1 - V_2) \cdot Y_{\text{series}12}$$

Note: Because all the calculations are done with per-unit values, some issues disappear.

Transformers become simple impedances, typically reduced to X_s only.

Voltages as line-to-neutral or line-to-line are the same in pu.

Powers as one-phase or 3-phase are the same in pu.

Generator busses are handled a little differently, see section 11.2, p. 530 in textbook.

ECE 3600 Power Flow notes p5

Example Consider the power system shown below. This example is strange because it's not in per unit values

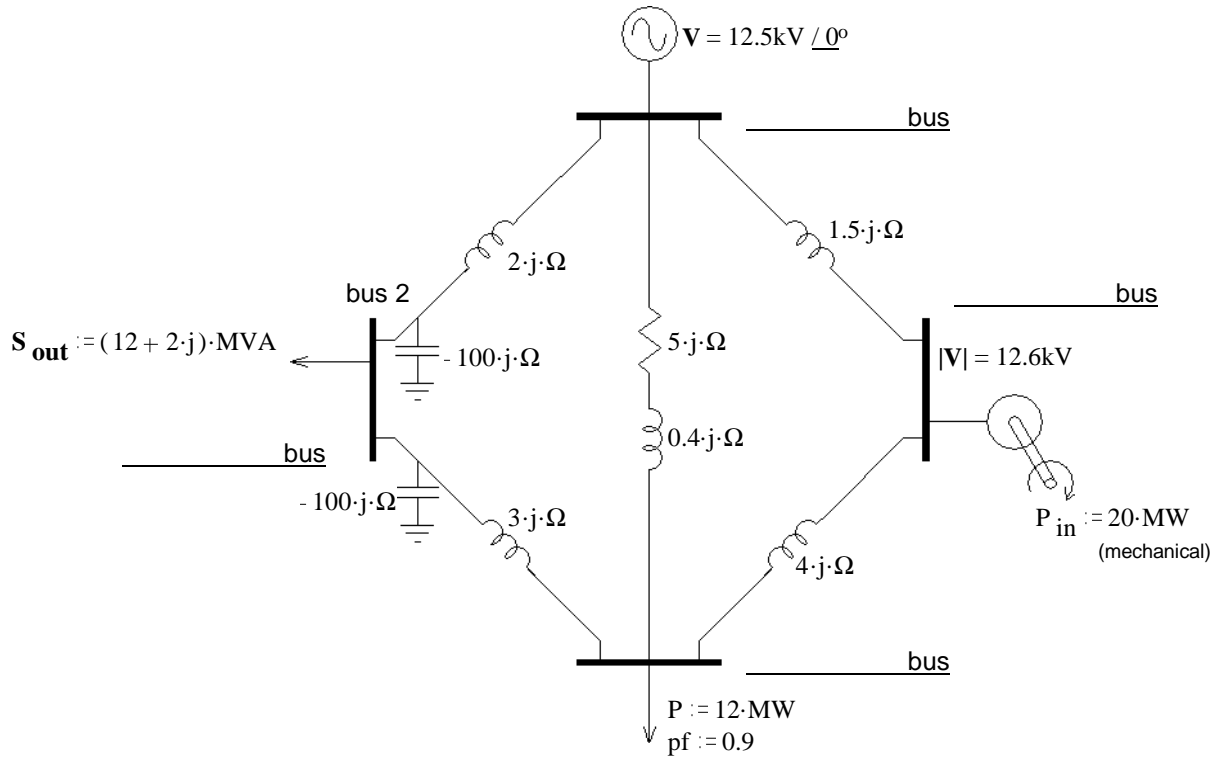

- Identify each bus as "slack", "load", or "generator".
- Number the slack bus as "bus 1". I have labeled bus 2. Label the other two on the drawing.
- Show V_1 , V_2 , V_3 , and V_4 on the drawing.
- Show I_1 , I_2 , I_3 , and I_4 on the drawing and draw arrows to indicate the direction of each.
- Find elements **A** and **B** in the matrix below and any zero elements.

$$\begin{bmatrix} I_1 \\ I_2 \\ I_3 \\ I_4 \end{bmatrix} = \begin{bmatrix} - & \mathbf{A} & - & - \\ - & \mathbf{B} & - & - \\ - & - & - & - \\ - & - & - & - \end{bmatrix} \cdot \begin{bmatrix} V_1 \\ V_2 \\ V_3 \\ V_4 \end{bmatrix}$$

ECE 3600 Power Flow notes p6

Example solution

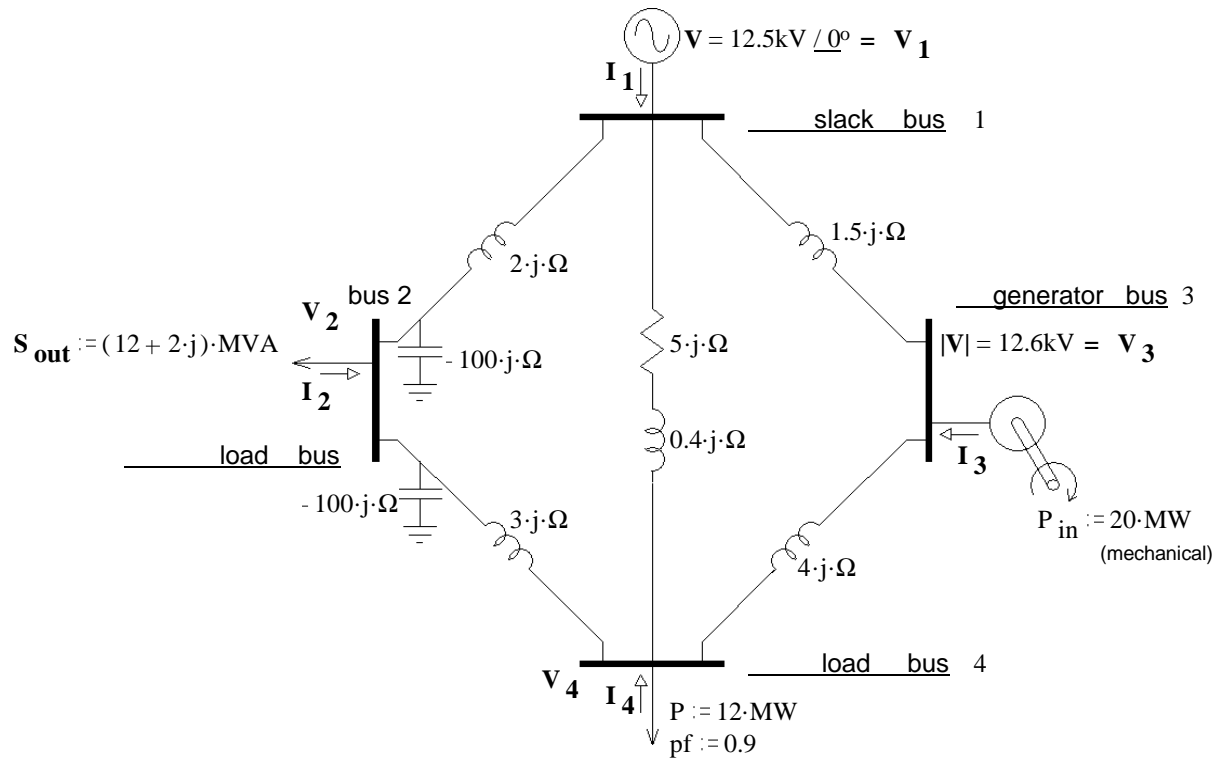

- Identify each bus as "slack", "load", or "generator".
- Number the slack bus as "bus 1". I have labeled bus 2. Label the other two on the drawing.
- Show V_1 , V_2 , V_3 , and V_4 on the drawing.
- Show I_1 , I_2 , I_3 , and I_4 on the drawing and draw arrows to indicate the direction of each.
- Find elements **A** and **B** in the matrix below and any zero elements.

$$\begin{bmatrix} I_1 \\ I_2 \\ I_3 \\ I_4 \end{bmatrix} = \begin{bmatrix} - & \mathbf{A} & - & - \\ - & \mathbf{B} & 0 & - \\ - & 0 & - & - \\ - & - & - & - \end{bmatrix} \cdot \begin{bmatrix} V_1 \\ V_2 \\ V_3 \\ V_4 \end{bmatrix}$$

$$Z_{12} := j \cdot 2 \cdot \Omega$$

$$\mathbf{A} := -\frac{1}{Z_{12}}$$

$$\mathbf{A} = 0.5j \cdot \frac{1}{\Omega}$$

$$Y_{2G} := \frac{1}{-100 \cdot j \cdot \Omega} + \frac{1}{-100 \cdot j \cdot \Omega}$$

$$Z_{21} := j \cdot 2 \cdot \Omega \quad Z_{23} := j \cdot 3 \cdot \Omega$$

$$\mathbf{B} := Y_{2G} + \frac{1}{Z_{21}} + \frac{1}{Z_{23}}$$

$$\mathbf{B} = -0.813j \cdot \frac{1}{\Omega}$$

No connection between bus 2 & 3, so: $Y_{23} = 0 = Y_{32}$

1. Consider the small power system shown below. values shown are per-unit.

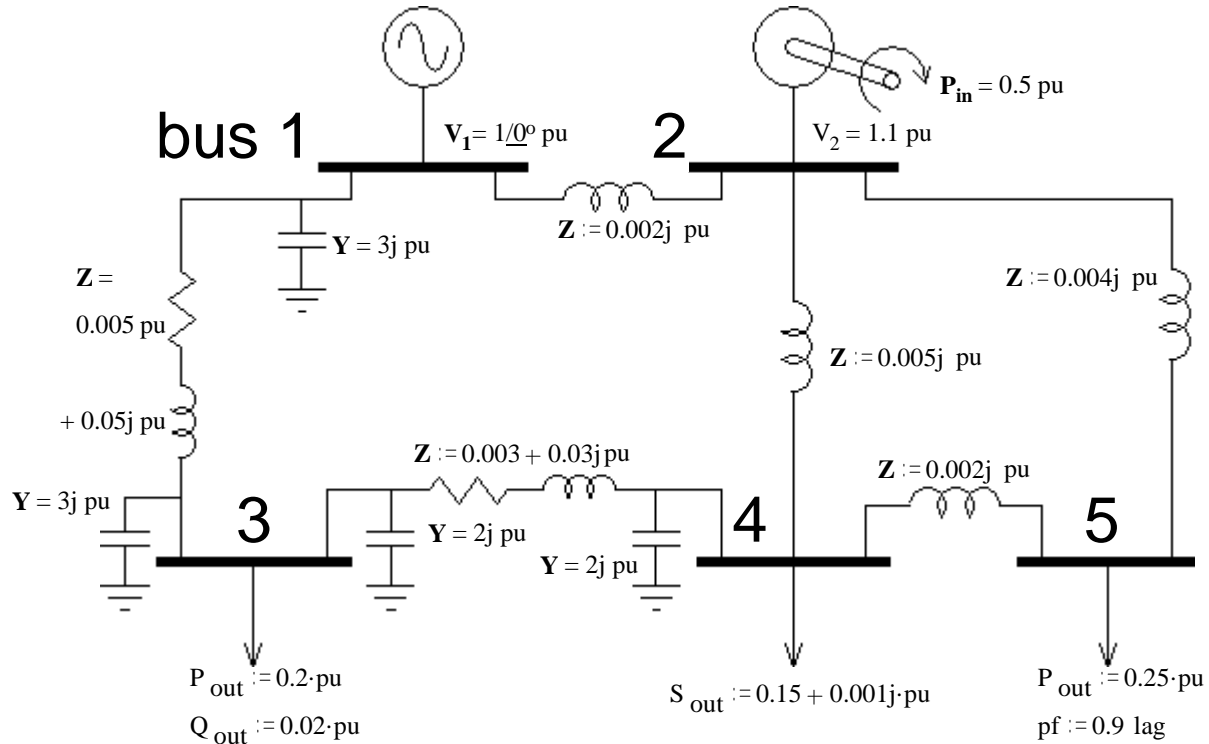

a) Identify each bus as "slack", "load", or "generator".

bus 1. _____ 2. _____ 3. _____ 4. _____ 5. _____

b) Show V_2 , V_3 , V_4 and V_5 on the drawing (as letters, not values).

c) Show I_1 , I_2 , I_3 , I_4 and I_5 on the drawing and draw arrows to indicate the direction of each.

d) What is the 5x5 matrix shown below called? _____

$$\begin{bmatrix} I_1 \\ I_2 \\ I_3 \\ I_4 \\ I_5 \end{bmatrix} = \begin{bmatrix} _ & _ & _ & _ & _ \\ _ & _ & _ & _ & _ \\ _ & _ & \mathbf{A} & \mathbf{B} & _ \\ _ & _ & _ & _ & _ \\ _ & _ & _ & _ & _ \end{bmatrix} \cdot \begin{bmatrix} V_1 \\ V_2 \\ V_3 \\ V_4 \\ V_5 \end{bmatrix}$$

e) A number of the elements of the matrix above are zero (0). Fill in all the zero elements.

f) Find elements **A** and **B** in the matrix above. You will need an extra sheet of paper for this.