

ECE 3600 Transmission Line notes

b

The beauty of electric power is that we have a ready source of zero-entropy energy available at any outlet. That energy can be made to do all kinds of things for us-- everything from washing our clothes to entertaining our children. But even as useful as electric power is, most of us don't want a power plant in our neighborhood. Power plants are best located close to energy sources and far from population centers. And that's the other great beauty of electric power (at least the AC version), it can be generated far from where it is used, transformed to very high voltages and moved efficiently over high-voltage transmission lines.

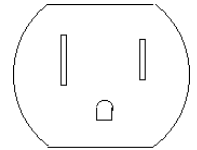

Watch the in-class slideshow of transmission line pictures

Pay attention to:

- Tower designs and sizes, and special designs at corners
- Multiple sets of 3-phase lines on a single set of towers
- Multiple sets of towers in the same corridor
- The number of insulator discs, which increase with voltage
- The wide variety of configurations
- Shield wire(s)
- Bundling & spacers
- Capacitor banks

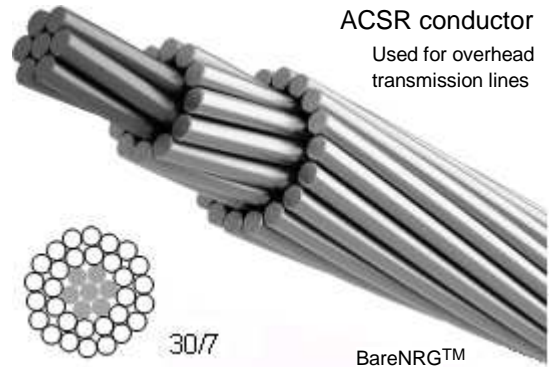

Shield Wire

The very highest wire is nearly always a **shield wire**, a grounded wire placed above the rest for lightning protection. May be simple steel cable or aluminum with steel reinforcement, often with a fiber optic data line at the center



BTW, Don't try this at home

Common Voltages

- 7.2·kV·√3 = 12.47·kV Local distribution, reduced to 240/120V at a transformer near you.
- 46·kV 69·kV Distribution within a city or county, between substations
- 115·kV 138·kV Short, light-use, rural, or older transmission lines or newer distribution lines
- 161·kV 230·kV Common transmission lines
- 345·kV 500·kV 765·kV Long-distance lines

Power handling capabilities increase roughly proportional to the square of the voltage, and decrease with line length, see curve later in the notes.

	50 mile	300 mile
230·kV	420·MW	140·MW
345·kV	1230·MW	410·MW
500·kV	3000·MW	1000·MW
765·kV	6800·MW	2300·MW

Insulators

These standard-sized discs are made from porcelain or glass and coupled together to form strings. They come in different tensile force ratings (15 to 50,000 lbs) and can handle over 20kV each. They also come in special styles for fog or contamination.

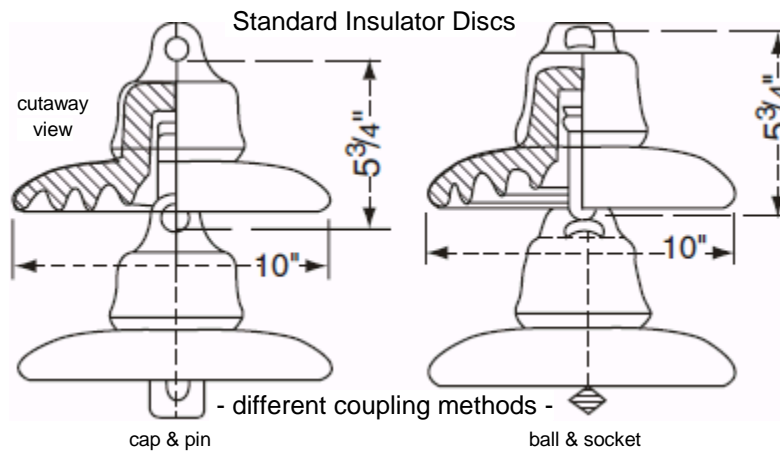

Number of standard insulator discs used in a string.

46·kV	3-4
69·kV	4-6
115·kV	7-9
138·kV	7-10
161·kV	10-13
230·kV	11-17
345·kV	16-21
500·kV	24-27
765·kV	30-35

The conductors themselves are not insulated. Electrical insulation would also be **thermal insulation**, and that would **not be good**. Because of the high currents these lines carry, they heat up. Hanging out in the air helps keep them from overheating. Overhead lines are electrically insulated from ground and one another only by air and distance.

Bundling & \$ Costs

As you saw in the pictures of transmission lines, it is not uncommon to use multiple conductors per phase. This is called bundling. Some 230kV lines and all lines above 230kV use bundling to reduce electric field strength and corona discharge (the source of the "crackle & pop" you can hear near high-voltage transmission lines).

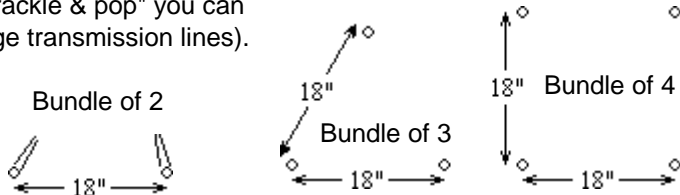

Bundling
Conductors
phase



Million\$ /mi

< 230-kV	1	
230-kV	1-2	1 - 2
345-kV	2-3	2 - 3
500-kV	3-4	2 - 3.2
765-kV	4	2.5 - 4

Bundling reduces the electric field around the lines. Multiple small-radius lines look like a single line of much greater radius, consequentially:



Line Parameters

- R = resistance = $r \cdot \text{len}$ upper case for the whole line, lower case for resistance per unit length, len for length.
- L = inductance = $l \cdot \text{len}$ X = reactance = $x \cdot \text{len} = \omega \cdot l \cdot \text{len}$
- C = capacitance = $c \cdot \text{len}$ Y = admittance = $y \cdot \text{len} = j \cdot \omega \cdot c \cdot \text{len}$
- G = conductance to ground = $g \cdot \text{len}$ caused primarily by corona discharge, usually neglected.

Resistance, R or r



$$R = \frac{\rho \cdot \text{len}}{A}$$

len = length of line
A = cross-sectional area
 ρ = resistivity
increases with temperature

$$\rho_{T2} = \frac{M + T_2}{M + T_1} \cdot \rho_{T1} = \frac{M + T_2}{M + 20} \cdot \rho$$

Resistance increases with:

Temperature + 20% or more

Frequency ("skin effect") + ~3% for 60 Hz

Spiraling The aluminum conductors in the cables are longer because of the twisting + 1 to 2%

Material	% Conductivity	ρ at 20 °C Resistivity $\times 10^{-8} \cdot \Omega \cdot \text{m}$	M Temperature Constant
Copper			
Annealed	100.0%	1.72	234.5 °C
Hard-drawn	97.3%	1.77	241.5 °C
Aluminum			
Hard-drawn	61.0%	2.83	228.1 °C
Silver	108.0%	1.59	243 °C
Steel	2 - 14.0%	12 - 88	180 - 980 °C

The large currents handled by transmission lines can cause significant heating of the lines, which causes the resistance to increase, making the problem even worse. Additionally, this heating causes the metal of the lines to expand and sag lower toward the ground, which can be a problem.

$$r = \text{series resistance per unit length of the line} = \frac{\rho}{A} \left(\frac{\Omega}{\text{m}} \right) \text{ OR } \frac{1000 \cdot \rho}{A} \left(\frac{\Omega}{\text{km}} \right) \text{ The units will be important}$$

Inductance, L or l



Your textbook goes through 5 pages of work and explanation (p.450 - 455) to get to the following expression of inductance per unit length of a single-phase, two-wire transmission line. Despite that, it will still yield some useful information.

$$l = \frac{\mu}{\pi} \cdot \left(\frac{1}{4} + \ln \left(\frac{D}{r} \right) \right) \left(\frac{\text{henry}}{\text{m}} \right)$$

D = spacing between line (phases)

r = radius of the conductor

$$\text{series reactance per unit length} = x = \omega \cdot \frac{\mu}{\pi} \cdot \left(\frac{1}{4} + \ln \left(\frac{D}{r} \right) \right) \cdot 1000 \left(\frac{\text{henry}}{\text{km}} \right)$$

$\mu_0 := 4 \cdot \pi \cdot 10^{-7} \frac{\text{henry}}{\text{meter}}$ = permeability of a vacuum, air is about the same

The useful information, if D ↑, then l ↑, x ↑ and, if r ↑, then l ↓, x ↓, also true for 3-phase lines

Line voltage, V ↑, D ↑, x ↑ If the voltage and power handling of a line increase, then D must also increase.

This is BAD, but can be effectively countered by bundling.

Capacitance, C or c

Another 5 pages yields: $c = \frac{\pi \cdot \epsilon}{\ln\left(\frac{D}{r}\right)} \cdot 10^6 \left(\frac{\mu F}{m}\right)$ $\epsilon_0 := 8.554 \cdot 10^{-12} \frac{\text{farad}}{\text{meter}}$ = permittivity of a vacuum = $\epsilon_0 = 8.554 \cdot 10^{-3} \frac{\mu F}{km}$

capacitive admittance to ground = $y = j \cdot \omega \cdot \frac{\pi \cdot \epsilon}{\ln\left(\frac{D}{r}\right)} \cdot 10^9 \left(\frac{\mu S}{km}\right)$ (sometimes we get sloppy about the j)
 (y actually includes the j, without the j, it's susceptance (B or b))

if D ↗, then c ↘, y ↘ usually not good
 and, if r ↗, then c ↗, y ↗ usually good

See more in books by Weeks & Glover/Sarma/Overbye

Conductance to Ground or Other Phases, G or g

$G = g \cdot \text{len}$ caused by corona discharge and leakage across insulators, usually neglected.

Bundling



Bundling makes the multiple small-radius lines look like a single line of much greater radius, so:

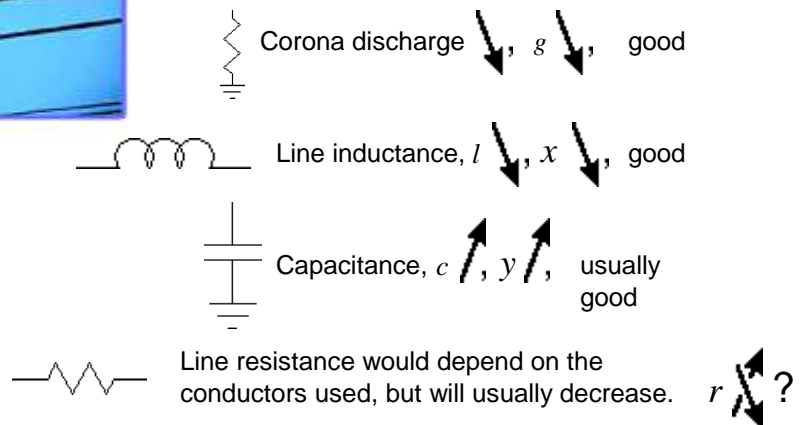

Underground Cables

Common for distribution in residential areas and downtown urban areas. Very problematic for high voltages and long distances.

High Capacitance

By definition, these cables are always in close proximity to ground potential, plus they are usually made with a grounded outer conductive shield. This makes them big capacitors. While a bit of added capacitance in a neighborhood distribution system may be OK or even good, the amount you get in transmission systems is BAD. Using High-Voltage DC (HVDC) for underground and underwater transmission is a way to get around the problem of capacitive admittance, but has its own issues.

Heat problems

The thick electrical insulation also keeps the heat in, which may require forced liquid cooling systems and limits power carrying capability.

Very Expensive for transmission lines, esp. considering the reduced power rating.

Underground lines is a field unto itself and beyond the scope of this class.



Overhead Transmission Line Conductors

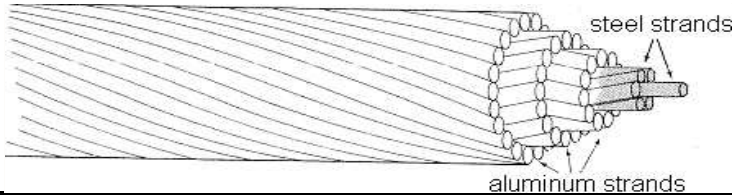

Overhead Transmission lines are usually **Aluminum Conductor Steel Reinforced (ACSR)** cables. This one is 54/7 "Cardinal".

Numbers below are not much use, b/c
Based on a 1-foot spacing

ACSR Conductor Codeword	Aluminum area		Cable Strands AL/Steel	Resistance				Capacitive admittance 60Hz ($\mu\text{S}/\text{km}$)	Inductive Reactance			Ampacity (A)
	AWG or kcmil	mm ²		DC 20°C (Ω/km)	AC 25°C (Ω/km)	AC 50°C (Ω/km)	AC 75°C (Ω/km)		25°C 60Hz (Ω/km)	50°C 60Hz (Ω/km)	75°C 60Hz (Ω/km)	
Turkey	6	13.3	6/1	2.106	2.149	2.461	2.677	4.37	0.394	0.456	0.472	105
Swan	4	21.18	6/1	1.322	1.352	1.572	1.713	4.59	0.377	0.430	0.449	140
Swanate	4	21.12	7/1	1.309	1.335	1.519	1.693	4.62	0.371	0.407	0.427	140
Sparrow	2	33.59	6/1	0.830	0.850	1.010	1.102	4.84	0.361	0.404	0.420	185
Sparate	2	33.54	7/1	0.823	0.840	0.974	1.083	4.87	0.358	0.387	0.397	185
Robin	1	42.41	6/1	0.659	0.676	0.810	0.886	4.97	0.351	0.390	0.400	210
Raven	1/0	53.52	6/1	0.522	0.535	0.646	0.709	5.11	0.341	0.374	0.381	240
Quail	2/0	67.33	6/1	0.413	0.427	0.531	0.577	5.26	0.335	0.367	0.371	275
Pigeon	3/0	85.12	6/1	0.328	0.338	0.397	0.476	5.41	0.325	0.354	0.358	315
Penguin	4/0	107.2	6/1	0.261	0.270	0.351	0.381	5.50	0.316	0.344	0.344	365
Waxwing	266.8	135	18/1	0.211	0.216	0.237	0.259	5.70	0.296	0.296	0.296	445
Partridge	266.8	134.9	26/7	0.209	0.214	0.234	0.255	5.81	0.289	0.289	0.289	455
Merlin	336.4	170.2	18/1	0.167	0.172	0.188	0.205	5.86	0.271	0.271	0.271	515
Linnet	336.4	170.6	26/7	0.166	0.170	0.186	0.203	5.98	0.280	0.280	0.280	530
Oriole	336.4	170.5	30/7	0.165	0.168	0.185	0.201	6.03	0.277	0.277	0.277	530
Chickadee	397.5	200.9	18/1	0.142	0.145	0.160	0.173	6.03	0.281	0.281	0.281	575
Ibis	397.5	201.3	26/7	0.140	0.144	0.158	0.172	6.09	0.274	0.274	0.274	590
Pelican	477	242.3	18/1	0.118	0.121	0.133	0.145	6.21	0.274	0.274	0.274	640
Flicker	477	241.6	24/7	0.117	0.120	0.132	0.144	6.26	0.268	0.268	0.268	670
Hawk	477	241.6	26/7	0.117	0.120	0.132	0.144	6.29	0.267	0.267	0.267	660
Hen	477	241.3	30/7	0.116	0.119	0.131	0.142	6.35	0.263	0.263	0.263	660
Osprey	556.5	282.5	18/1	0.101	0.104	0.114	0.124	6.33	0.268	0.268	0.268	710
Parakeet	556.5	282.3	24/7	0.101	0.103	0.114	0.124	6.41	0.263	0.263	0.263	720
Dove	556.5	282.6	26/7	0.100	0.103	0.113	0.123	6.43	0.261	0.261	0.261	730
Rook	636	323.1	24/7	0.0879	0.0909	0.0994	0.1083	6.54	0.258	0.258	0.258	780
Grosbeak	636	321.8	26/7	0.0876	0.0902	0.0988	0.1076	6.57	0.256	0.256	0.256	790
Drake	795	402.6	26/7	0.0702	0.0728	0.0794	0.0863	6.81	0.248	0.248	0.248	910
Tern	795	403.8	45/7	0.0709	0.0738	0.0807	0.0876	6.72	0.252	0.252	0.252	890
Rail	954	483.8	45/7	0.0591	0.0617	0.0676	0.0732	6.92	0.245	0.245	0.245	970
Cardinal	954	484.5	54/7	0.0587	0.061	0.0673	0.0728	6.98	0.242	0.242	0.242	990
Curlew	1033.5	525.5	54/7	0.0541	0.0564	0.062	0.0673	7.07	0.239	0.239	0.239	1040
Bluejay	1113	565.5	45/7	0.0509	0.0535	0.0584	0.0633	7.12	0.240	0.240	0.240	1070
Bittern	1272	644.4	45/7	0.0443	0.0472	0.0515	0.0558	7.27	0.235	0.235	0.235	1160
Lapwing	1590	804.1	45/7	0.0354	0.0384	0.042	0.0453	7.56	0.226	0.226	0.226	1340
Falcon	1590	806.2	54/19	0.0354	0.0381	0.0423	0.0459	7.63	0.222	0.222	0.222	1360
Bluebird	2156	1092	84/19	0.0263	0.0296	0.0321	0.0344	8.02	0.214	0.214	0.214	1610
Kiwi	2167	1098	72/7	0.0262	0.0302	0.0317	0.0348	7.98	0.223	0.223	0.223	1607
Thrasher	2312	1172	76/19	0.0246	0.0282	0.0299	0.0328	8.10	0.213	0.213	0.213	1673
Joree	2515	1274	76/19	0.0226	0.0266	0.0279	0.0305	8.22	0.210	0.210	0.210	1751

Warning, the column for Capacitance is often given as reactance per length rather than admittance which means you have to **divide** by line length to get overall capacitance.

Types of conductors used for overhead lines:

Aluminum Conductor Steel Reinforced (ACSR) conductors are the most common.

All Aluminum Conductor (AAC).

All Aluminum-Alloy Conductor (AAAC).

Aluminum Conductor Alloy-Reinforced (ACAR).

Alumoweld, an aluminum-clad steel conductor.

Expanded ACSR, which includes filler material between the steel and aluminum to make the outer diameter bigger.

Surge Impedance, SIL & Characteristic Impedance

Take a representative km somewhere along the transmission line, where the voltage is the nominal voltage at 0°. Over that km, the 1 ϕ complex power due to the voltage would be:

$$V_{LN} \overline{I_{LN}} = V_{LN} \overline{\Delta I_L} = V_{LN} \overline{[V_{LN} \cdot (g + j \cdot \omega c)]} = V_{LN}^2 \cdot \overline{(g + j \cdot \omega c)} = V_{LN}^2 \cdot (g - j \cdot \omega c)$$

And the reactive power would be: $-V_{LN}^2 \cdot (j \cdot \omega c)$ assuming the voltage is constant

The 1 ϕ complex power due to the current would be:

$$\Delta V_{LN} \overline{I_L} = [I_L \cdot (r + j \cdot \omega l)] \cdot \overline{I_L} = I_L^2 \cdot (r + j \cdot \omega l) \quad \text{assuming the current is constant}$$

And the reactive power would be: $I_L^2 \cdot (j \cdot \omega l)$

If the two reactive powers were equal and opposite, then the Q of the line would be 0, IE:

$$I_L^2 \cdot (j \cdot \omega l) = -[-V_{LN}^2 \cdot (j \cdot \omega c)] \quad \text{and} \quad \frac{V_{LN}}{I_L} = \sqrt{\frac{j \cdot \omega l}{j \cdot \omega c}} = \sqrt{\frac{l}{c}} = \mathbf{Z_0} \quad \text{Where } \mathbf{Z_0} \text{ is the magnitude of the impedance I should hook to the line here to get this to happen.}$$

$$\text{Surge Impedance} = \mathbf{Z_0} = \sqrt{\frac{l}{c}} = \sqrt{\frac{L}{C}} = \sqrt{\frac{x}{|y|}}$$

SO, to get the line Q to be 0 (or pretty close), hook this impedance to the end of the line. If $\mathbf{Z_0}$ was purely resistive, and the line voltage at the receiving end were nominal, then the load power would be one "Surge Impedance Load", 1SIL.

$$\text{SIL:} \quad \text{SIL} = 3 \cdot \frac{V_R^2}{Z_0} = \frac{V_{LL}^2}{Z_0} \quad \text{Sometimes load powers or line power capabilities are expressed in terms of SIL.}$$

Characteristic Impedance

The complex version of the surge impedance arises out of the full-fledged calculation of the distributed effect the transmission line parameters. It is known as the characteristic impedance and is EXACTLY the same as the characteristic impedance you found (or will find) for transmission lines in your Electromagnetics (EM) class.

$$\mathbf{Z_C} = \sqrt{\frac{r + j \cdot \omega l}{g + j \cdot \omega c}} = \sqrt{\frac{r + j \cdot x}{g + y}} = \sqrt{\frac{R + j \cdot X}{G + Y}} \quad \text{We only use this in calculations for long-length lines}$$

$$\text{And if the line is lossless, then: } \mathbf{Z_C} = \mathbf{Z_0} = \sqrt{\frac{l}{c}} = \sqrt{\frac{L}{C}} = \sqrt{\frac{x}{|y|}} \quad \text{ONLY if } r = 0 = g$$

Propagation Constant

Another number used in calculations for long-length lines is the propagation constant: $\gamma = \sqrt{(r + j \cdot x) \cdot (g + y)}$ Although power transmission lines share some characteristics with EM transmission lines, the wavelength (λ) for 60Hz is about 5000km (3000mi), so, no Smithcharts or stub tuning for 60Hz. However, 360°/5000km still works out to 1°/13.9km, so phase-angle changes may be important to consider.

Transients

Transients on the power lines can happen on much shorter time scales than the 60Hz waveform. Lightning strikes are assumed to produce peak currents of 10 to 20,000 amps in 1.2 μ s and then exponentially decay at a much slower rate. Switching lines on or off can result in impulses which peak in about 250 μ s and last longer than lightning impulses. These impulses produce traveling waves on the lines which can bounce back and forth along the line.

The first concern raised by these impulses is the insulation, especially in transformers, where insulation failure results in very-expensive, permanent damage. Studies are done of the Basic Insulation Level (BIL) for lightning impulses and Basic Switching Insulation Level (BSL) for switching impulses.

The insulation discs used with transmission lines are rarely damaged permanently by over-voltages and flashovers.



Surge & Lightning Arresters are highly nonlinear devices which have a high resistance at normal voltages and low resistance at voltages over their threshold. They protect transformers and other devices from over-voltages.



Transient stability of transmission lines play only a part in the overall transient and dynamic stability of entire power systems. Stability and the control of voltage, frequency and generators are fields beyond the scope of this class.

HVDC Transmission Lines

High-Voltage DC (HVDC) is used for long-distance transmission of large amounts of power, and for some underground and most underwater transmission. HVDC is also used as a power link between two AC grids which are not in sync.

The insulation requirements of transmission lines are set by the peak voltage, but the power is determined by the RMS voltage. For sinusoidal waveforms the peak is 40% higher than the RMS. For DC they are both the same, so the RMS voltage can be 40% higher and the power can be twice as much for the same insulation. For each positive line there will also be a negative line with the same voltage magnitude so the neutral current can be zero.

HVDC systems require rectifiers at the sending end to change the AC to DC and an inverter at the receiving end to return the power to AC. These require very high-voltage, very high-power, very expensive, semi-conductor parts. The sending end typically uses transformers with Y-Y, Y-Δ and Δ-Y windings arranged so the rectifiers see a peak voltage every 30° of phase angle (every 1.39ms). This minimizes the need for filtering.

HVDC lines and the associated power conversions are a field unto themselves and beyond the scope of this class.

Transmission Line Typical Values

Nominal Voltages	Bundling Conductors phase	Line Parameters			Characteristic Impedance (Surge Impedance) Ω	SIL Surge Impedance Loading MW	Line Current at 1 SIL A	Line Current at 3 SIL (maximum) A
		r Ω/km	ωl Ω/km	ωc μS/km				
69-kV	1	0.47	0.47	3.3	383	12.4	104	312
138-kV	1	0.14	0.48	3.4	380	50	210	629
230-kV	1	0.055	0.489	3.373	380	140	350	1050
345-kV	2	0.037	0.376	4.518	290	410	687	2061
500-kV	3	0.029	0.326	5.220	250	1000	1155	3464
765-kV	4	0.013	0.339	4.988	260	2250	1700	5100

Power Handling Capability

	Multiple of SIL	230kV 345kV 500kV 765kV				Reason For Limit
		MW	MW	MW	MW	
Short-length Lines: < 80km (50 miles)	3	3·SIL= 420	1230	3000	6750	Overheating lines
Medium-length: 80 - 240 km (50 - 150 mi)	1.75 - 3	1.75·SIL= 245	718	1750	3938	Voltage Drop
Long-length: > 240 km (150 mi)	1.0 - 1.75	1·SIL= 140	410	1000	2250	Transient Stability

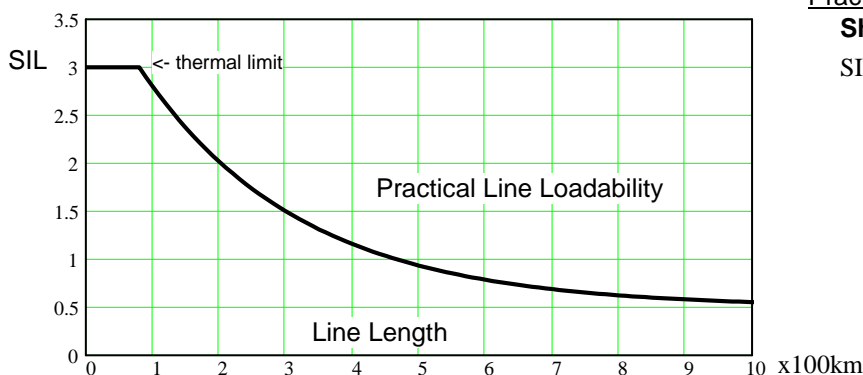

Practical Limitations

Short Lines should be limited to 3 times the SIL in order to limit the I²R heating of the line.

Mid-length lines are limited in order to limit the voltage drop across line less than 5%. $\frac{|V_R|}{|V_S|} \leq 0.95$

Long-length lines can become unstable, which limits loadability. The power angle should be limited: $\delta \leq 30^\circ$

Sometimes series capacitors and/or shunt inductors are added to these lines to "compensate" for the line reactance.

Power Flow (Driven by δ)

Power and current are pushed down the line by a phase angle difference (δ , the power angle), NOT a voltage difference.

if you neglect the line losses $P_{in} = P_{out} = 3 \cdot \frac{V_S \cdot V_R \cdot \sin(\delta)}{X_{line}}$

The power grid often has multiple paths for power to flow from one substation to another. Power will flow down the various paths depending only on the line impedances and lengths. Phase-Shifting transformers allow operators of the lines to take control over the power flow. This use is still relatively rare.

Phase-Shifting transformers are more commonly found where one control area connects to another within a power region (tie line). In this position, they can control power flow from area to area.

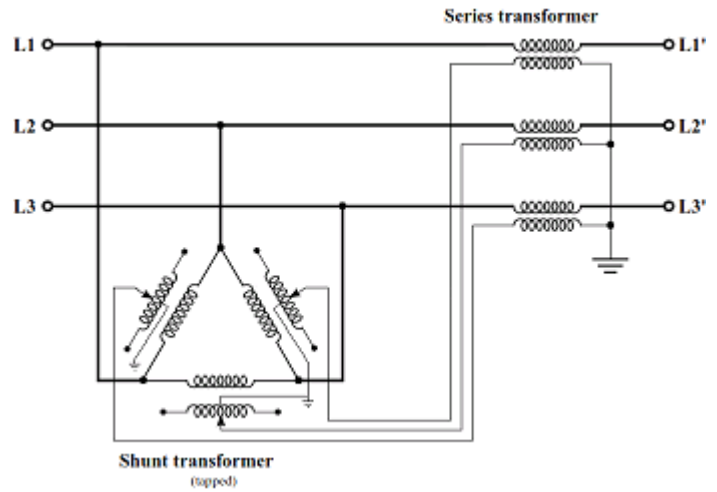

Combating Voltage Sag The effect of Adding Capacitance at Receiving end of a Transmission Line

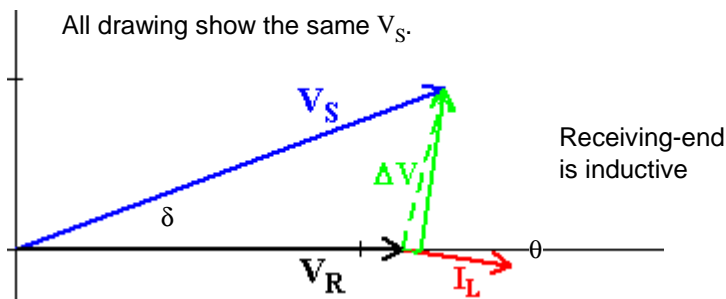

Watch the Animations Shown in class

- V_S is the line-neutral voltage at the sending end.
- V_R is the line-neutral voltage at the receiving end.
- ΔV is the voltage difference between the two ends.
- I_L is the line current.

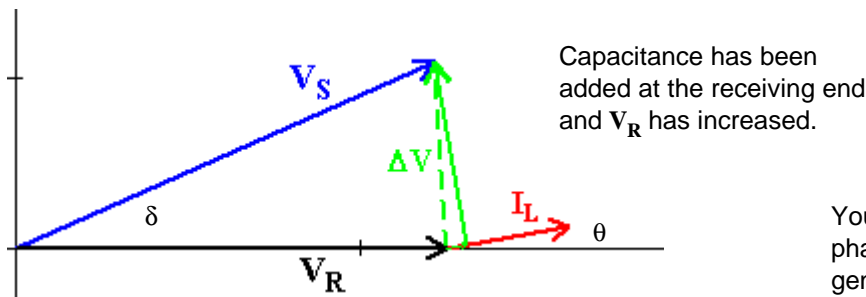

You should notice a similarity between this phasor diagram and that of synchronous generators.

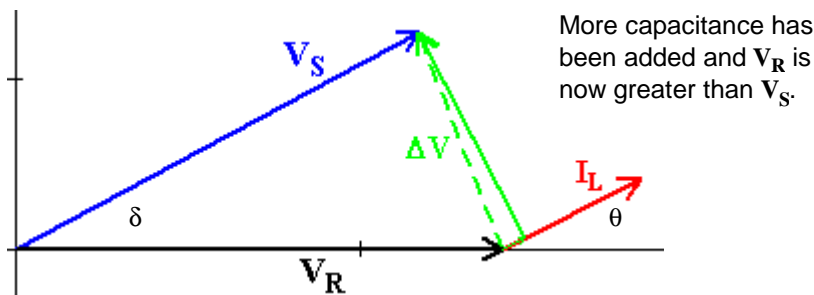

Power companies add capacitance at the receiving end of transmission lines if the voltage is too low in order to raise the voltage. These drawing show how this works.

Sources:

Electric Machinery and Power System Fundamentals, Stephen J, Chapman
Power Systems Analysis and Design, Glover & Sarma
First Course on Power Systems, Ned Mohan
Transmission and Distribution of Electrical Energy, Walter L. Weeks
Standard Handbook for Electrical Engineers, Fink & Beaty
www.nexans.us

ECE 3600 Lumped-Parameter Transmission Line Models

c

Long-length Lines: over 240 km (150 miles) (over 200 mi in some texts)

Need:	<u>Units</u>			
line length:	len , d	m or km		stick to the same unit length for all parameters miles may also be used
Resistance per unit length:	r	$\frac{\Omega}{m}$ or $\frac{\Omega}{km}$		
Inductance per unit length:	l	$\frac{H}{m}$ or $\frac{H}{km}$	OR	Inductive reactance per unit length: x $\frac{\Omega}{m}$ or $\frac{\Omega}{km}$
Capacitance per unit length:	c	$\frac{F}{m}$ or $\frac{F}{km}$	OR	Capacitance admittance per unit length: y $\frac{S}{m}$ or $\frac{S}{km}$
Conductance to ground:	g	$\frac{S}{m}$ or $\frac{S}{km}$	Common assumption:	$g := 0 \cdot \frac{S}{km}$ S := siemens = $\frac{1}{\Omega}$

Find:		<u>Units</u>
Characteristic Impedance:	$Z_c = \sqrt{\frac{j \cdot x + r}{y + g}}$	Ω
Propagation constant:	$\gamma = \sqrt{(j \cdot x + r) \cdot (y + g)}$	$\frac{1}{m}$ or $\frac{1}{km}$

If your calculator doesn't have hyperbolic trig functions

(but can handle complex-number exponents)

Series impedance $Z_{series} = Z_c \cdot \sinh(\gamma \cdot len) = Z_c \cdot \frac{e^{\gamma \cdot len} - e^{-\gamma \cdot len}}{2}$ Ω

Shunt admittance: $\frac{Y_{shunt}}{2} = \frac{1}{Z_c} \cdot \tanh\left(\gamma \cdot \frac{len}{2}\right) = \frac{1}{Z_c} \cdot \frac{e^{\frac{\gamma \cdot len}{2}} - e^{-\frac{\gamma \cdot len}{2}}}{e^{\frac{\gamma \cdot len}{2}} + e^{-\frac{\gamma \cdot len}{2}}} = \frac{1}{Z_c} \cdot \frac{\sqrt{e^{\gamma \cdot len}} - \sqrt{e^{-(\gamma \cdot len)}}}{\sqrt{e^{\gamma \cdot len}} + \sqrt{e^{-(\gamma \cdot len)}}}$ Ω

OR

Shunt impedance: $2 \cdot Z_{shunt} = \frac{Z_c}{\tanh\left(\gamma \cdot \frac{len}{2}\right)}$ S or $\frac{1}{\Omega}$

If your calculator can't handle complex exponents

$e^{(a+b \cdot j)} = e^a \cdot e^{b \cdot j} = e^a / b$ (in radians)

Model:

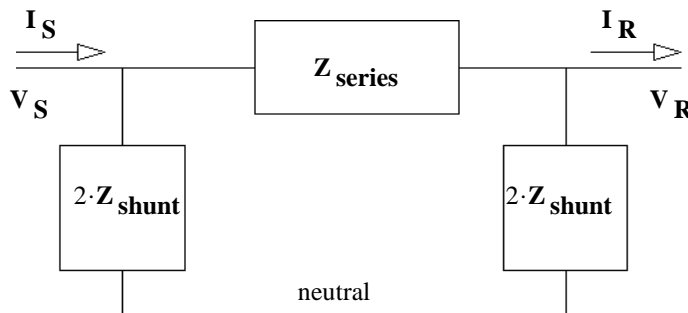

Medium-length Lines: 80 - 240 km (50 to 150 miles)

(100 - 200 mi in some texts)

Need:

		<u>Units</u>		
line length:	len , d	m or km		stick to the same unit length for all parameters miles may also be used
Resistance per unit length:	r	$\frac{\Omega}{m}$ or $\frac{\Omega}{km}$		
Inductance per unit length:	l	$\frac{H}{m}$ or $\frac{H}{km}$	OR	Inductive reactance per unit length: x $\frac{\Omega}{m}$ or $\frac{\Omega}{km}$
Capacitance per unit length:	c	$\frac{F}{m}$ or $\frac{F}{km}$	OR	Capacitance admittance per unit length: y $\frac{S}{m}$ or $\frac{S}{km}$
Conductance to ground:	g	$\frac{S}{m}$ or $\frac{S}{km}$		Common assumption: $g := 0 \cdot \frac{S}{km}$

Find:

			<u>Units</u>
Surge Impedance:	$Z_0 = \sqrt{\frac{x \cdot j}{y}}$	Only needed if load is in terms of SIL	Ω
Series Resistance:	$R_{line} = r \cdot len$		Ω
Series impedance	$Z_{series} = (r + j \cdot x) \cdot len$		Ω
Shunt admittance:	$\frac{Y_{shunt}}{2} = y \cdot \frac{len}{2}$		S := siemens = $\frac{1}{\Omega}$
OR			
Shunt impedance:	$2 \cdot Z_{shunt} = \frac{2}{y \cdot len}$		Ω

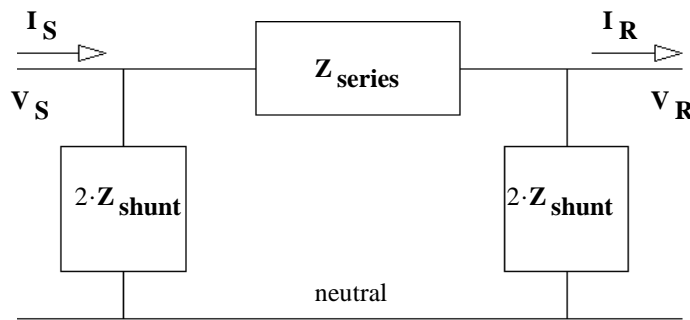

OR:

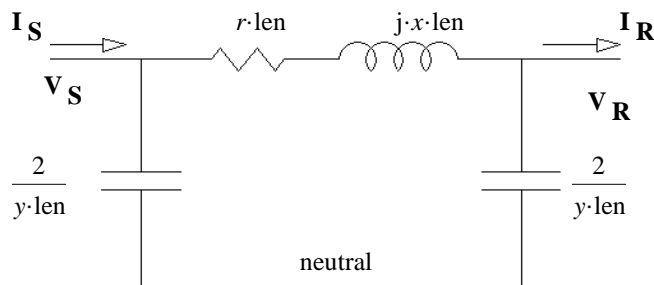

Short-length Lines: less than 80km (50 mi)
(less than 100 mi in some texts)

Same as above but without the capacitors

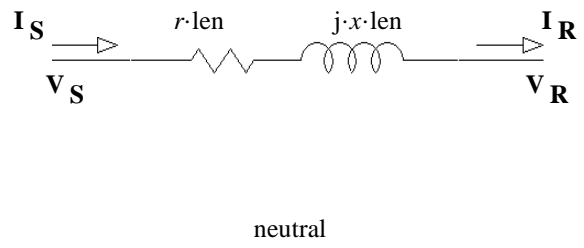

ECE 3600 Transmission Line Examples

b

Ex1. A 500 kV transmission line is 500 km long and has the line parameters shown below. Use the long-length model to find V_S and I_S if the line is loaded to 900 MVA and $|V_{RLL}|$ is 490 kV. Assume the phase angle of V_R is 0° and assume load pf = 1.

$$\begin{aligned} \text{len} &:= 500 \cdot \text{km} & V_{RLL} &:= 490 \cdot \text{kV} & V_R &:= \frac{V_{RLL}}{\sqrt{3}} & S_{1\phi} &:= \frac{900 \cdot \text{MVA}}{3} \\ r &:= 0.029 \cdot \frac{\Omega}{\text{km}} & \text{Assume: } g &:= 0 \cdot \frac{\text{S}}{\text{km}} & & & & \\ x &:= 0.326 \cdot \frac{\Omega}{\text{km}} & y &:= j \cdot (5.220 \cdot 10^{-6}) \cdot \frac{\text{S}}{\text{km}} & & & & \end{aligned}$$

Note: These are typical values for a 500 kV transmission line

Long-length line model:

Characteristic Impedance: $Z_c := \frac{\sqrt{j \cdot x + r}}{\sqrt{y + g}} \quad Z_c = 250.151 - 11.104j \cdot \Omega$

Propagation constant: $\gamma := \sqrt{(j \cdot x + r) \cdot (y + g)} \quad \gamma = 5.797 \cdot 10^{-5} + 1.306 \cdot 10^{-3}j \cdot \frac{1}{\text{km}}$

Series impedance: $Z_{\text{series}} := Z_c \cdot \sinh(\gamma \cdot \text{len}) \quad Z_{\text{series}} = 12.508 + 151.772j \cdot \Omega$

If it were med. length: $\text{len} \cdot (r + j \cdot x) = 14.5 + 163j \cdot \Omega$

Shunt admittance: $Y_{\text{shunt}} := \frac{2}{Z_c} \cdot \tanh\left(\gamma \cdot \frac{\text{len}}{2}\right) \quad \frac{Y_{\text{shunt}}}{2} = 4.49 \cdot 10^{-6} + 1.353 \cdot 10^{-3}j \cdot \text{S}$
(Not used in my solution)

Shunt impedance: $Z_{\text{shunt}} := \frac{Z_c}{2 \cdot \tanh\left(\gamma \cdot \frac{\text{len}}{2}\right)} \quad 2 \cdot Z_{\text{shunt}} = 2.451 - 738.924j \cdot \Omega$
If it were med. length: $\frac{2}{y \cdot \text{len}} = -766.284j \cdot \Omega$

Solve circuit:

$I_R := \frac{S_{1\phi}}{|V_R|}$ (Not complex in this case because pf = 1 otherwise include a phase angle calculated from the pf or load other information)

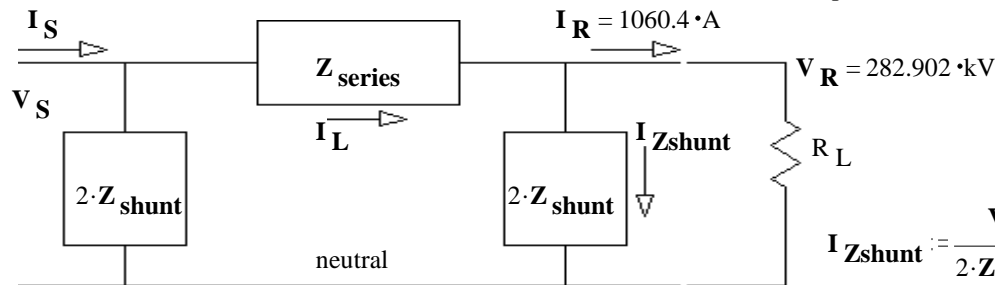

$$I_{Zshunt} := \frac{V_R}{2 \cdot Z_{shunt}}$$

$$I_{Zshunt} = 1.27 + 382.852j \cdot \text{A}$$

$$I_L := I_{Zshunt} + I_R \quad I_L = 1.062 \cdot 10^3 + 382.852j \cdot \text{A}$$

$$V_S := V_R + I_L \cdot Z_{\text{series}} \quad V_S = 2.381 \cdot 10^5 + 1.659 \cdot 10^5j \cdot \text{V} \quad |V_S| = 290.192 \cdot \text{kV} \quad \arg(V_S) = 34.874 \cdot \text{deg}$$

$$I_{ZshuntS} := \frac{V_S}{2 \cdot Z_{shunt}} \quad I_{ZshuntS} = -223.48 + 322.934j \cdot \text{A} \quad |\sqrt{3} \cdot V_S| = 502.628 \cdot \text{kV}$$

$$I_S := I_{ZshuntS} + I_L \quad I_S = 838.23 + 705.786j \cdot \text{A} \quad |I_S| = 1096 \cdot \text{A} \quad \arg(I_S) = 40.097 \cdot \text{deg}$$

ECE 3600 Transmission Line notes p11

Ex 2. A 345 kV transmission line is 220 km long and has the line parameters shown below.
Find V_S and I_S if the line is loaded to 800MW with $pf = 91\%$ lagging. $|V_{RLL}|$ is 350 kV. $pf = 0.91$

$$\text{len} := 220 \cdot \text{km} \quad V_{RLL} := 350 \cdot \text{kV} \quad V_R := \frac{V_{RLL}}{\sqrt{3}} \quad \text{Assume the phase angle of } V_R \text{ is } 0^\circ \text{ if } V_R \text{ is given}$$

$$r := 0.037 \cdot \frac{\Omega}{\text{km}} \quad \text{Assume: } g := 0 \cdot \frac{\text{S}}{\text{km}} \quad \text{Note: These are typical values for a 345 kV transmission line}$$

$$x := 0.376 \cdot \frac{\Omega}{\text{km}} \quad y := j \cdot (4.518 \cdot 10^{-6}) \cdot \frac{\text{S}}{\text{km}}$$

Medium-length line model:

$$\text{Series impedance: } Z_{\text{series}} := (r + j \cdot x) \cdot \text{len} \quad Z_{\text{series}} = 8.14 + 82.72j \cdot \Omega$$

$$\text{Shunt admittance: } Y_{\text{shunt}} := y \cdot \text{len} \quad \frac{Y_{\text{shunt}}}{2} = 496.98j \cdot \mu\text{S}$$

Not used in my solution

$$\text{Shunt impedance: } Z_{\text{shunt}} := \frac{1}{y \cdot \text{len}} \quad 2 \cdot Z_{\text{shunt}} = -2.012 \cdot 10^3 j \cdot \Omega$$

Solve circuit:

$$S_{1\phi} := \frac{800 \cdot \text{MW}}{3 \cdot \text{pf}}$$

$$I_R := \frac{S_{1\phi}}{|V_R|} \cdot e^{-j \cdot \arccos(\text{pf})} \quad \text{(Negative phase angle because the pf is lagging)}$$

$$I_R = 1319.7 - 601.3i \cdot \text{A}$$

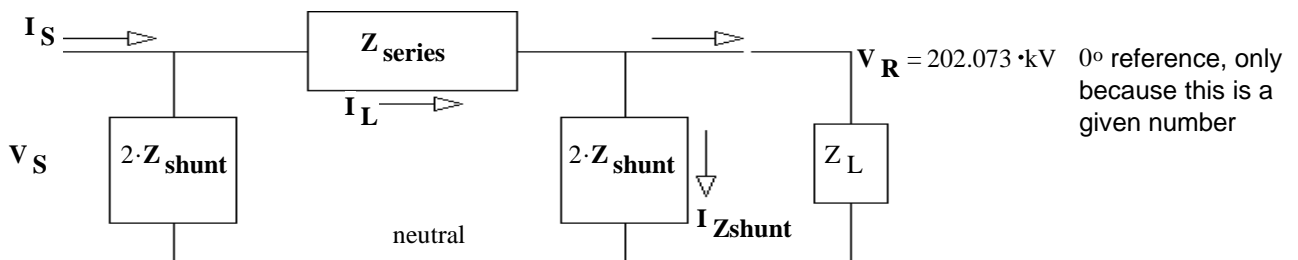

$$I_{Zshunt} := \frac{V_R}{2 \cdot Z_{\text{shunt}}}$$

$$I_{Zshunt} = 100.426j \cdot \text{A}$$

$$I_L := I_{Zshunt} + I_R$$

$$I_L = 1.32 \cdot 10^3 - 500.828j \cdot \text{A}$$

$$V_S := 0 \cdot V_R + I_L \cdot Z_{\text{series}}$$

$$V_S = 5.217 \cdot 10^4 + 1.051 \cdot 10^5 j \cdot \text{V}$$

$$|V_S| = 117.323 \cdot \text{kV} \quad \arg(V_S) = 63.598 \cdot \text{deg}$$

$$\text{Line voltage: } \sqrt{3} \cdot V_S = 203.209 \cdot \text{kV}$$

$$\text{power angle} = \delta = \arg(V_S) - \arg(V_R) = 63.598 \cdot \text{deg}$$

$$I_{ZshuntS} := \frac{V_S}{2 \cdot Z_{\text{shunt}}}$$

$$I_{ZshuntS} = -52.225 + 25.928j \cdot \text{A}$$

$$I_S := I_{ZshuntS} + I_L$$

$$I_S = 1.267 \cdot 10^3 - 474.9j \cdot \text{A}$$

$$|I_S| = 1353 \cdot \text{A}$$

$$\arg(I_S) = -20.541 \cdot \text{deg}$$

Ex3. A 230 kV transmission line has the following length and line parameters.

$$\text{len} := 150 \cdot \text{km} \quad r := 0.06 \cdot \frac{\Omega}{\text{km}} \quad x := 0.5 \cdot \frac{\Omega}{\text{km}} \quad g := 0 \cdot \frac{\text{S}}{\text{km}} \quad y := j \cdot (4 \cdot 10^{-6}) \cdot \frac{\text{S}}{\text{km}}$$

Medium-length line model:

Series impedance: $Z_{\text{series}} := (r + j \cdot x) \cdot \text{len} \quad Z_{\text{series}} = 9 + 75j \cdot \Omega$

Shunt admittance: $Y_{\text{shunt}} := y \cdot \text{len} \quad \frac{Y_{\text{shunt}}}{2} = 0.3j \cdot \text{mS}$

Shunt impedance: $Z_{\text{shunt}} := \frac{1}{y \cdot \text{len}} \quad 2 \cdot Z_{\text{shunt}} = -3.333j \cdot \text{k}\Omega$

a) The sending end is at rated voltage and the load is three, Y-connected, 250-Ω impedances with a power factor of 0.87, leading. Find the line current, I_{Line} .

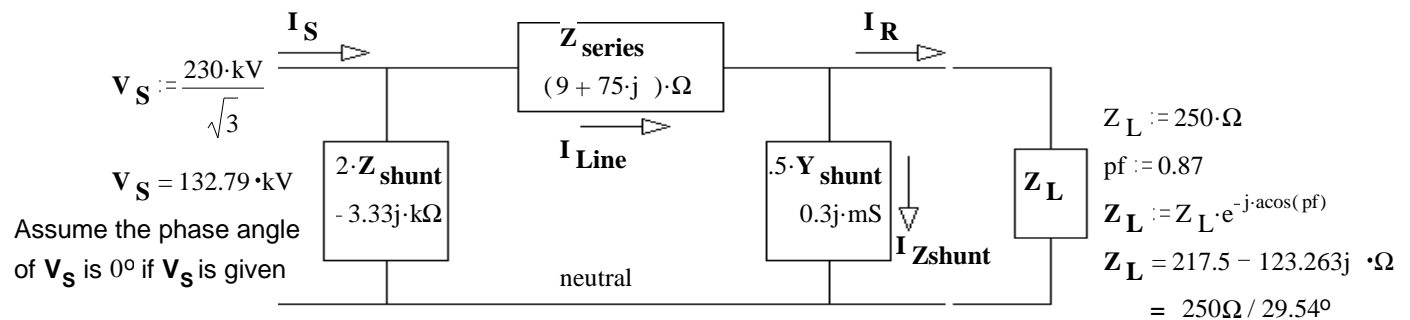

$$Z := Z_{\text{series}} + \frac{1}{\frac{Y_{\text{shunt}}}{2} + \frac{1}{Z_L}} \quad Z = 210.467 - 56.544j \cdot \Omega = 217.9 \Omega / \underline{-15.04^\circ}$$

$$I_{\text{Line}} := \frac{V_S}{Z} \quad I_{\text{Line}} = 588.459 + 158.096j \cdot \text{A} = 609.3 \text{A} / \underline{15.04^\circ}$$

b) Find the line voltage at the load.

$$I_{\text{Line}} \cdot Z_{\text{series}} = -6.561 + 45.557j \cdot \text{kV}$$

$$V_R := V_S - I_{\text{Line}} \cdot Z_{\text{series}} \quad V_R = 139.352 - 45.557j \cdot \text{kV} = 146.6 \text{kV} / \underline{-18.1^\circ}$$

$$\text{Receiving line voltage} = \sqrt{3} \cdot V_R = 253.9 \cdot \text{kV}$$

Notice that $|V_R|$ is bigger than $|V_S|$, this can happen when the receiving-end power factor is leading.

c) What is the "power angle" (δ)?

$$\delta = -\arg(V_R) = 18.104 \cdot \text{deg}$$

d) How much power is delivered to the load?

$$I_R := \frac{|V_R|}{|Z_L|} \quad P_L = 3 \cdot |V_R| \cdot I_R \cdot \text{pf} = 224.4 \cdot \text{MW}$$

Power estimate for the same $|V_R|$ and

$|V_S|$, but neglecting the line resistance:

$$\approx 3 \cdot \frac{|V_S| \cdot |V_R| \cdot \sin(18.1 \cdot \text{deg})}{|Z_{\text{series}}|} = 240 \cdot \text{MW}$$

e) Express this loading in terms of SIL

Surge Impedance: $Z_0 := \sqrt{\frac{j \cdot x}{y}} \quad Z_0 = 353.6 \cdot \Omega$

$$\frac{Z_0}{Z_L} = 1.414 \quad \text{SIL load}$$

Not asked for in this class