

**Armature**

The rotating part (rotor)

**Field** (Excitation)

Provided by the stationary part of the motor (Stator)

Permanent Magnet

Winding

Separately excited

Parallel with terminal voltage source (Shunt excited)

Series with terminal voltage source (Series excited)

**Commutator and commutation**

Rotary contacts and brushes which keep switching the current direction in the armature so that the motor torque is always in the same direction.

Explained and visualized in class

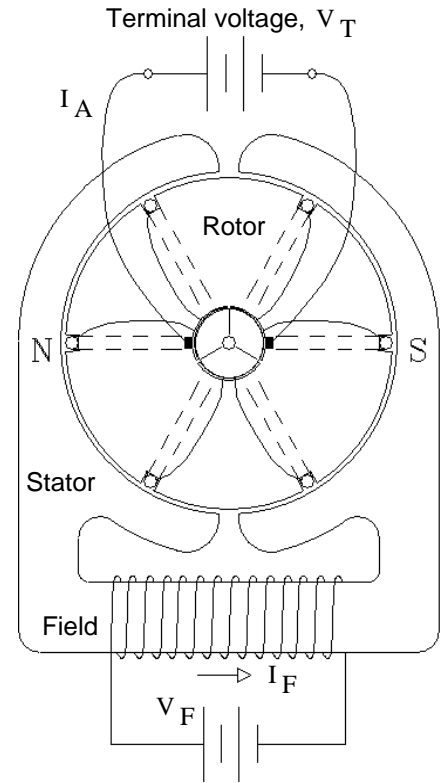

**Electrical Model**

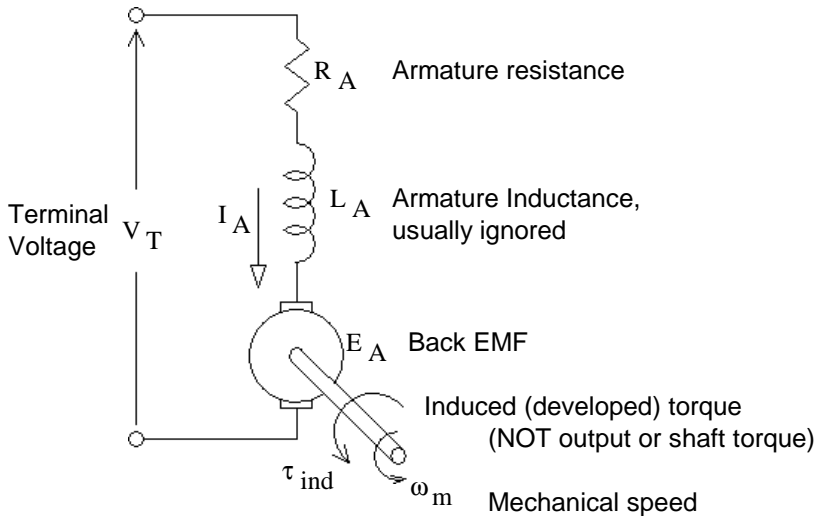

**Important relationships**

$$E_A = K \cdot \phi \cdot \omega_m$$

$$\tau_{ind} = K \cdot \phi \cdot I_A$$

$$\frac{\omega_2}{\omega_1} = \frac{E_{A2} \cdot \phi_1}{E_{A1} \cdot \phi_2} = \frac{n_2}{n_1}$$

$$\frac{\tau_{ind2} \cdot \phi_1}{\tau_{ind1} \cdot \phi_2} = \frac{I_{A2}}{I_{A1}}$$

**Simplified Model we will use**

$$V_T = I_A \cdot R_A + E_A$$

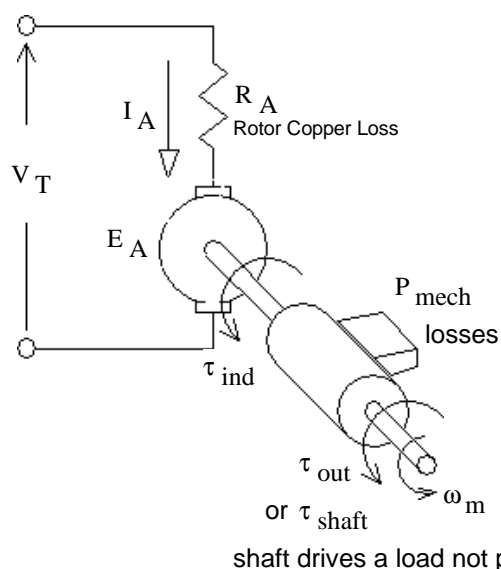

$$P_{conv} = E_A \cdot I_A = \tau_{ind} \cdot \omega_m$$

$$I_A = \frac{P_{conv}}{E_A} \quad E_A = \frac{P_{conv}}{I_A}$$

These are often substituted in other eq.

$$V_T = I_A \cdot R_A + E_A \quad \text{becomes:}$$

$$V_T = I_A \cdot R_A + \frac{P_{conv}}{I_A} \quad \text{OR} \quad 0 = I_A^2 - \frac{V_T}{R_A} \cdot I_A + \frac{P_{conv}}{R_A}$$

$$\text{OR} \quad V_T = \frac{P_{conv}}{E_A} \cdot R_A + E_A \quad \text{OR} \quad 0 = E_A^2 - V_T \cdot E_A + P_{conv} \cdot R_A$$

## Powers

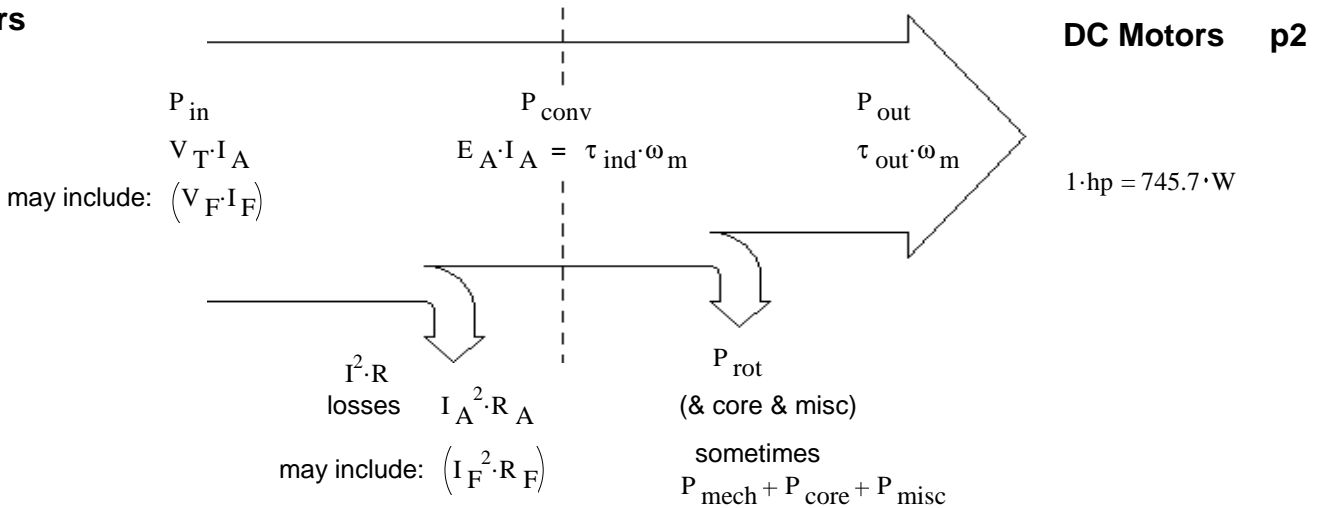

## Nameplate Operation

The Nameplate gives the rated Voltage, Current(s), Speed and output Power (often as horsepower, hp). 1·hp = 745.7·W  
This is considered full-load operation.

## Motor Constant, K

Our book defines the motor constant such that it does not include the field flux,  $\phi$ . Often the motor constant is defined differently, as  $K\phi$ , but just called K, which is a function of the field current.  $K\phi$  (or K) is most easily found by operating the motor as a generator with no load, then  $V_T = E_A$ .

**Spin Direction:** Reverse the leads to either of the windings and the motor will run in the opposite direction.

## Mechanical Loads, Losses and Torque - Speed Curves

And how the different loads translate into motor calculations.

Constant power  $P_{cp} = \tau_{cp} \cdot \omega_m$        $I_{Acp} = \frac{P_{cp}}{E_{Ac}}$        $E_{Acp} = \frac{P_{cp}}{I_{Acp}}$

If an output or loss power is constant for all speeds, then the torque is inversely proportional to the speed.

This is highly unlikely in real life.

But is still useful to calculate how your motor's speed under a certain load condition.

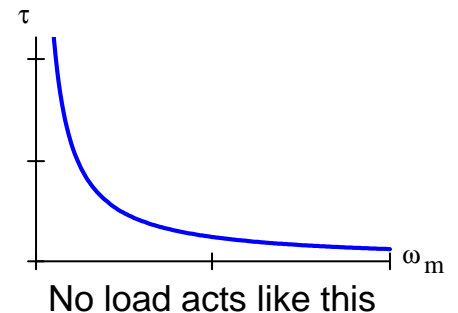

Power is Proportional to speed      Torque is Constant

$$\frac{\omega_2}{\omega_1} = \frac{P_2}{P_1} = \frac{n_2}{n_1}$$

Note: P may be only the fraction of the total power, the fraction that is proportional to speed.

If a power is proportional to speed, then the torque is constant with speed.

Conversely, if a torque is constant for all speeds, the power is proportional to speed.

A bit more likely in real life.

$$\tau_{ind} = K \cdot \phi \cdot I_A$$

If a torque is constant for all speeds,  $\phi \cdot I_A$  is constant.

$$\tau_c = K \cdot \phi \cdot I_{Ac}$$

$$P_c = \tau_c \cdot \omega_m$$

And,  $I_A$  is constant if  $\phi$  is constant.

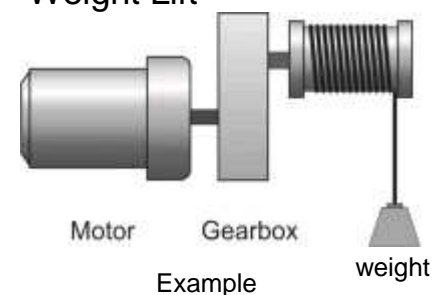
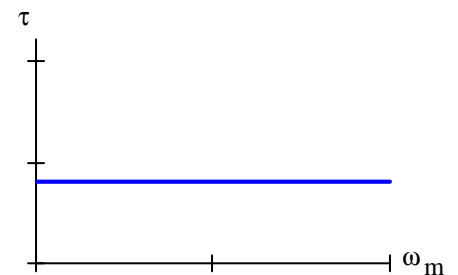

Power is proportional to the Square of the speed, Torque is Proportional to speed

Torque is proportional to speed AND,  $I_A$  is proportional to speed

$$\frac{\omega_2}{\omega_1} = \frac{\tau_2}{\tau_1} = \frac{\phi_2 \cdot I_{A2}}{\phi_1 \cdot I_{A1}} = \frac{n_2}{n_1} = \frac{E_{A2} \cdot \phi_1}{E_{A1} \cdot \phi_2}$$

Note:  $\tau$  is only the torque that is proportional to speed.

AND, if ALL torque is proportional to speed, AND flux ( $\phi$ ) is a constant,

$$\frac{n_2}{n_1} = \frac{V_{T2}}{V_{T1}}$$

Power is proportional to the square of the speed.

$$\frac{\omega_2^2}{\omega_1^2} = \frac{P_2}{P_1} = \frac{n_2^2}{n_1^2}$$

Note: P is only the power that is proportional to speed<sup>2</sup>.

Models simple dynamic friction.

Approximates more real-life loads, torque required to turn a load usually increases with speed.

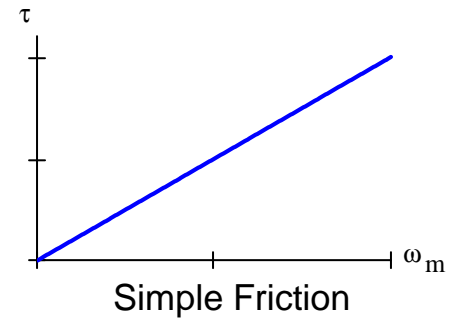

$$\tau_p = K \cdot \phi \cdot I_{Ap} = K_{\text{pload}} \cdot \omega_m$$

$$P_p = \tau_p \cdot \omega_m = K_{\text{pload}} \cdot \omega_m^2$$

Torque is proportional to the Square of the speed

When an object moves through the air or a fluid, the drag force on the object is usually characterized by a drag coefficient ( $C_D$ ) which relates the drag force to the velocity squared. This drag coefficient is then adjusted for friction drag, pressure drag, laminar flow and turbulent flow. In short, it's complicated, but a torque can be proportional to the rotational speed squared, at least over some region of operation, especially when air or fluid motion is involved. For us, that means that true load torque-speed curves often curve upward.

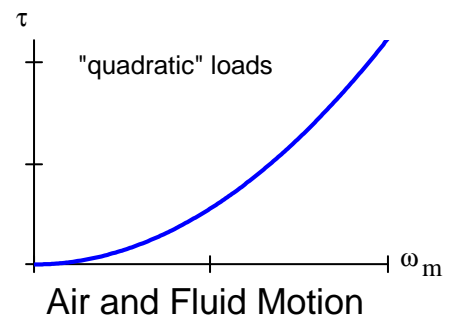

$$\frac{\omega_2^2}{\omega_1^2} = \frac{\tau_2}{\tau_1} = \frac{\phi_2 \cdot I_{A2}}{\phi_1 \cdot I_{A1}} = \frac{n_2^2}{n_1^2} = \frac{E_{A2}^2 \cdot (\phi_1)^2}{E_{A1}^2 \cdot (\phi_2)^2}$$

Also notice the "Breakaway torque" in the last torque-speed curve. That is due to the static, sticky friction (stiction). Almost all real loads have some stiction.

$$\tau_s = K \cdot \phi \cdot I_{As} = K_{\text{sload}} \cdot \omega_m^2$$

$$P_s = \tau_s \cdot \omega_m = K_{\text{sload}} \cdot \omega_m^3$$

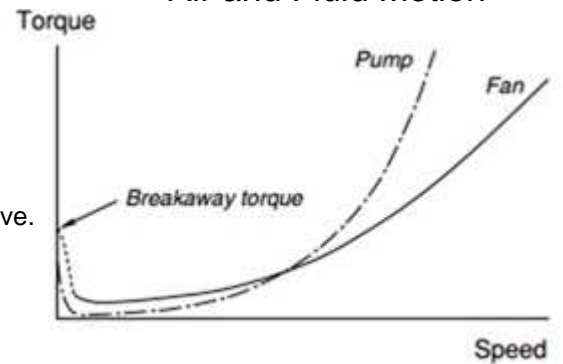

Torque-speed characteristics for fan- and pump-type loads

A combination of the last three cases

Plus some Stiction

Most likely in real life.

Superposition, separate causes and add results.

In these cases the power (P), torque ( $\tau$ ) and even the armature current and EMF ( $I_A$  and  $E_A$ ) may be split into multiple pieces, each with its own characteristics.

$$P_{\text{conv}} = P_{cp} + P_c + P_p + P_s$$

$$\tau_{\text{ind}} = \tau_{cp} + \tau_c + \tau_p + \tau_s$$

$$I_A = I_{Acp} + I_{Ac} + I_{Ap} + I_{As}$$

$$E_A = E_{Acp} + E_{Ac} + E_{Ap} + E_{As}$$

The parts are usually expressed in proportionalities to some known point of operation, like that shown on the nameplate.

Then use the proportionalities to substitute into the basic motor equation:  $V_T = I_A \cdot R_A + E_A$

## Torque - Speed curves

$$V_T = I_A \cdot R_A + E_A \quad \text{replace: } I_A = \frac{\tau_{\text{ind}}}{K \cdot \phi} \quad E_A = K \cdot \phi \cdot \omega_m$$

$$\text{to get: } V_T = \frac{\tau_{\text{ind}}}{K \cdot \phi} \cdot R_A + K \cdot \phi \cdot \omega_m \quad \tau_{\text{ind}} = (V_T - K \cdot \phi \cdot \omega_m) \cdot \frac{K \cdot \phi}{R_A}$$

$$\text{At 0 speed (locked rotor): } V_T = \frac{\tau_{\text{ind}}}{K \cdot \phi} \cdot R_A \quad \tau_{\text{ind}} = (V_T) \cdot \frac{K \cdot \phi}{R_A}$$

$$\text{At max speed (no induced torque): } V_T = K \cdot \phi \cdot \omega_{\text{max}} \quad 0 = (V_T - K \cdot \phi \cdot \omega_{\text{max}}) \cdot \frac{K \cdot \phi}{R_A}$$

### Output Torque instead of Induced Torque

If lost torque is proportional to speed:

$$\tau_{\text{shaft}} = \tau_{\text{ind}} - \text{fric} \cdot \omega_m \quad V_T = \frac{\tau_{\text{shaft}} + \text{fric} \cdot \omega_m}{K \cdot \phi} \cdot R_A + K \cdot \phi \cdot \omega_m = \frac{\tau_{\text{shaft}}}{K \cdot \phi} \cdot R_A + \left( \frac{\text{fric} \cdot R_A}{K \cdot \phi} + K \cdot \phi \right) \cdot \omega_m$$

## DC Motor Types and Characteristics

### Permanent Magnet

Permanent-Magnet motors are typically small. They can be quite powerful for their size, especially if made with rare-earth magnets. These motors are common in children's toys and servo systems. Some electric cars use Large permanent-magnet DC motors.

The characteristics are like the separately excited motor with a constant flux. Since the flux can't be changed, the motor constant times flux,  $K\phi$ , is usually simplified to just a different motor constant, usually also called  $K$ , which includes the constant flux.

### Separately Excited

The field flux comes from current flowing through a field winding, which is supplied by a separate power source or at a different voltage than  $V_T$ .

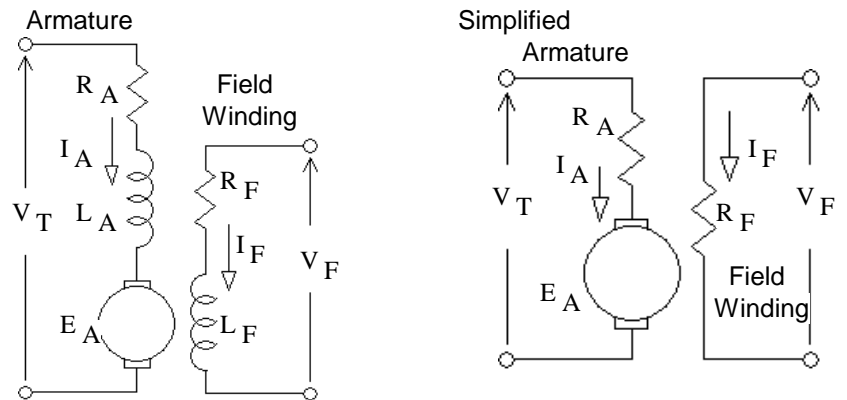

Permanent Magnet or Separately excited

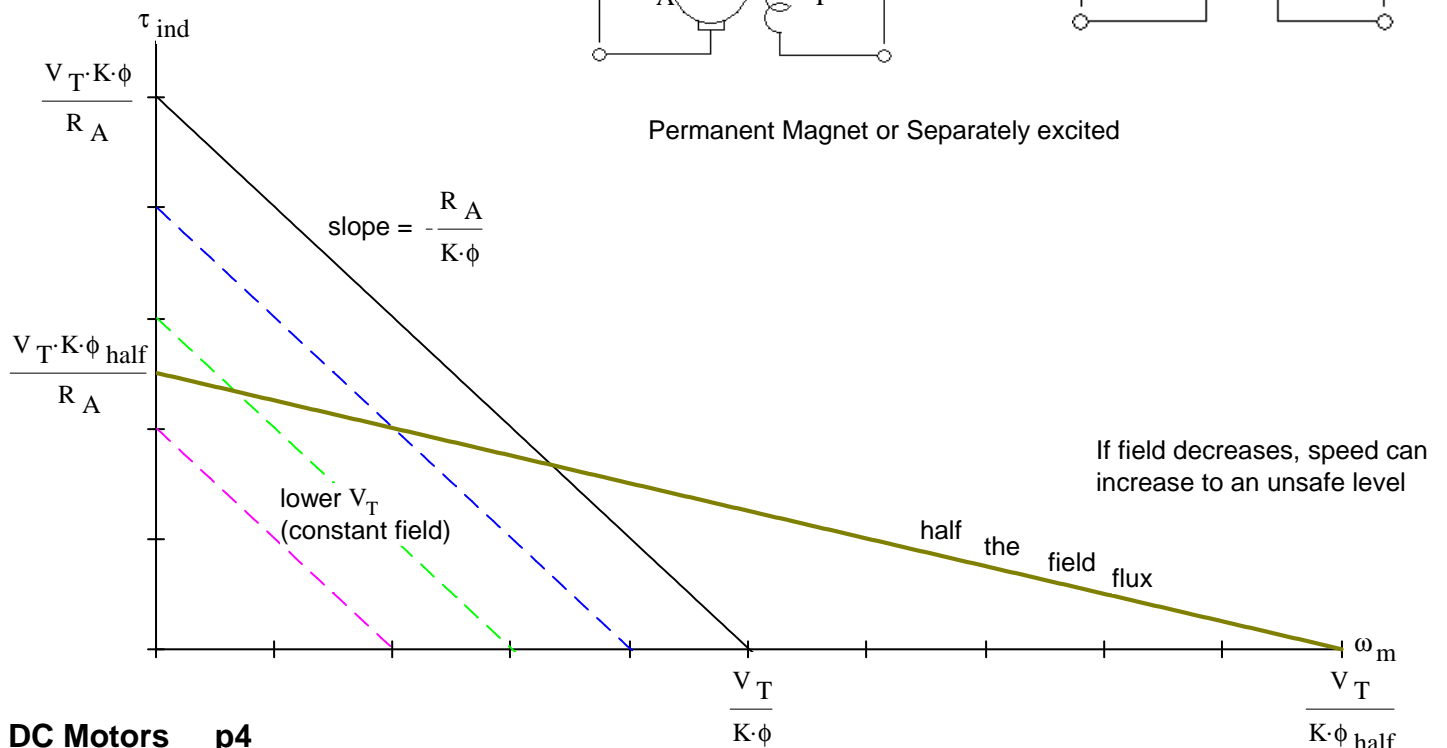

$$\tau_{shaft} = \tau_{ind} - \text{fric} \cdot \omega_m$$

$$V_T = \frac{\tau_{shaft} + \text{fric} \cdot \omega_m}{K \cdot \phi} \cdot R_A + K \cdot \phi \cdot \omega_m = \frac{\tau_{shaft}}{K \cdot \phi} \cdot R_A + \left( \frac{\text{fric} \cdot R_A}{K \cdot \phi} + K \cdot \phi \right) \cdot \omega_m$$

$$\tau_{shaft} = \left[ V_T - \left( \frac{\text{fric} \cdot R_A}{K \cdot \phi} + K \cdot \phi \right) \cdot \omega_m \right] \cdot \frac{K \cdot \phi}{R_A}$$

At 0 speed (locked rotor):  $\frac{V_T \cdot K \cdot \phi}{R_A}$

At max speed:  
induced torque all lost to friction  
(no output or shaft torque)

$$V_T = \left( \frac{\text{fric} \cdot R_A}{K \cdot \phi} + K \cdot \phi \right) \cdot \omega_{max}$$

$$\omega_{max} = \frac{V_T}{\frac{\text{fric} \cdot R_A}{K \cdot \phi} + K \cdot \phi}$$

= Max speed or no-load speed

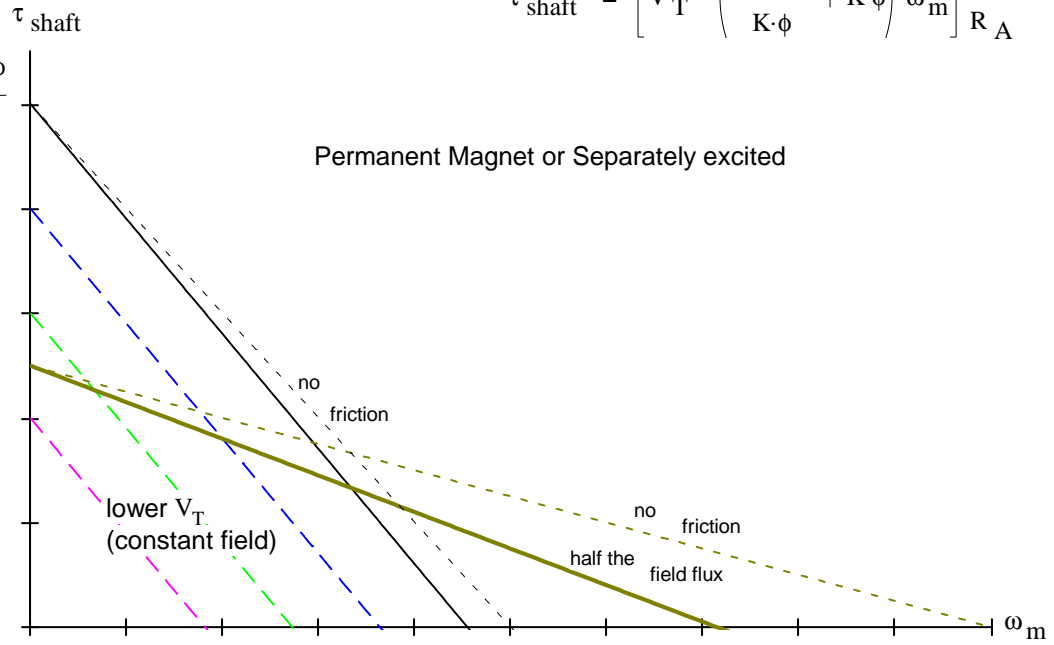

**Shunt Excited**

Field winding is connected in parallel with the armature to the same terminal voltage source,  $V_T$ .

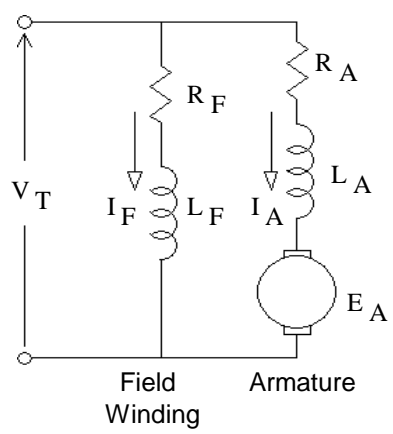

If flux is proportional to field current  $\phi = c \cdot I_F = c \cdot \frac{V_T}{R_F}$   $c = \text{the "core constant"}$

At 0 speed (locked rotor):  $V_T = \frac{\tau_{ind}}{K \cdot \phi} \cdot R_A$

so:  $\tau_{ind} = (V_T) \cdot \frac{K \cdot \phi}{R_A} = (V_T) \cdot \frac{K \cdot \left( c \cdot \frac{V_T}{R_F} \right)}{R_A} = \frac{V_T^2 \cdot K \cdot c}{R_A \cdot R_F}$

At max speed (no induced torque):  $V_T = K \cdot \phi \cdot \omega_{max}$

$$\omega_{max} = \frac{V_T}{K \cdot \phi} = \frac{V_T}{K \cdot (c \cdot I_F)} = \frac{R_F}{K \cdot c}$$

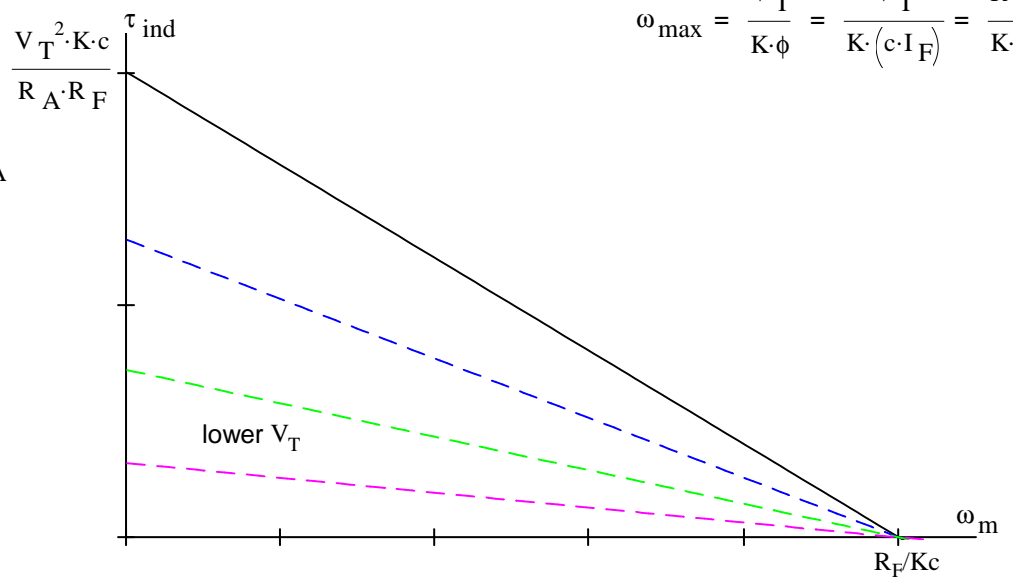
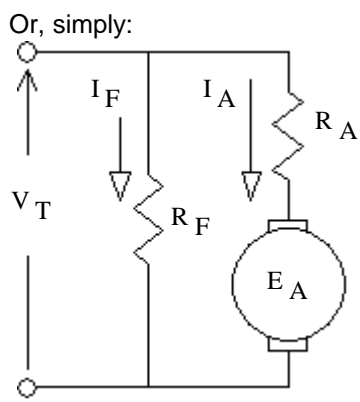

Output Torque instead of Induced Torque, If lost torque is proportional to speed:

$$\tau_{\text{shaft}} = \tau_{\text{ind}} - \text{fric} \cdot \omega_m \quad V_T = \frac{\tau_{\text{shaft}} + \text{fric} \cdot \omega_m}{K \cdot \phi} \cdot R_A + K \cdot \phi \cdot \omega_m = \frac{\tau_{\text{shaft}}}{K \cdot \phi} \cdot R_A + \left( \frac{\text{fric} \cdot R_A}{K \cdot \phi} + K \cdot \phi \right) \cdot \omega_m$$

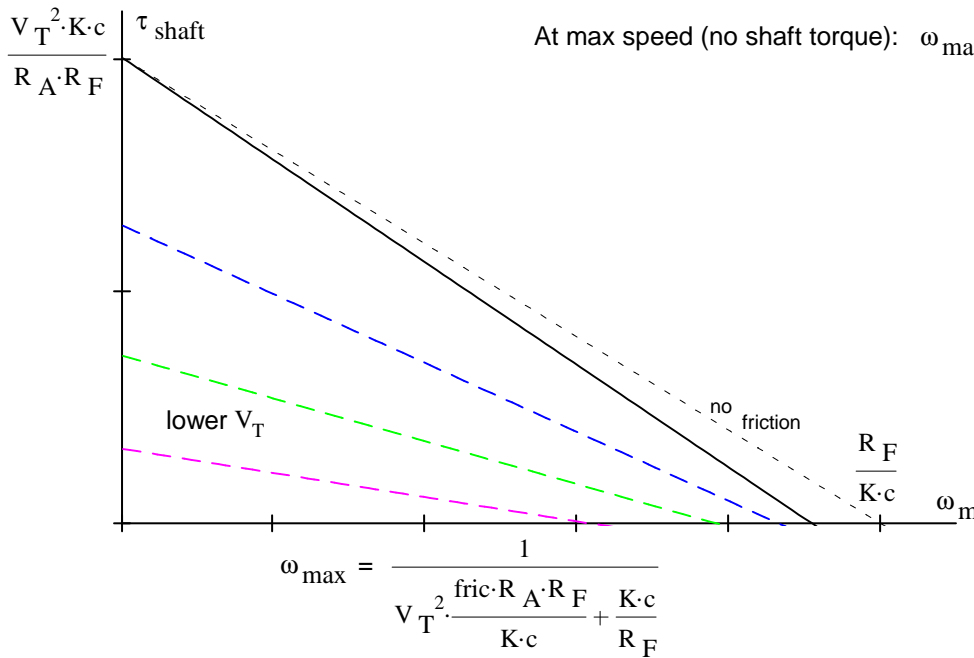

$$\begin{aligned} \text{At max speed (no shaft torque): } \omega_{\text{max}} &= \frac{V_T}{\frac{\text{fric} \cdot R_A}{K \cdot \left( c \cdot \frac{V_T}{R_F} \right)} + K \cdot \left( c \cdot \frac{V_T}{R_F} \right)} \\ &= \frac{V_T}{\frac{\text{fric} \cdot R_A \cdot R_F}{K \cdot c \cdot V_T} + K \cdot c \cdot \frac{V_T}{R_F}} \\ &= \frac{1}{V_T^2 \cdot \frac{\text{fric} \cdot R_A \cdot R_F}{K \cdot c} + \frac{K \cdot c}{R_F}} \end{aligned}$$

**Series Excited (Often called an AC/DC or Universal Motor)**

Field winding is connected in series with the armature and is designed with much thicker windings, so it can handle much larger current and has much less resistance. The resistance of the field winding is now called  $R_S$ . Since  $R_S$  is in series with  $R_A$ , they are often combined into  $R_{AS}$ .

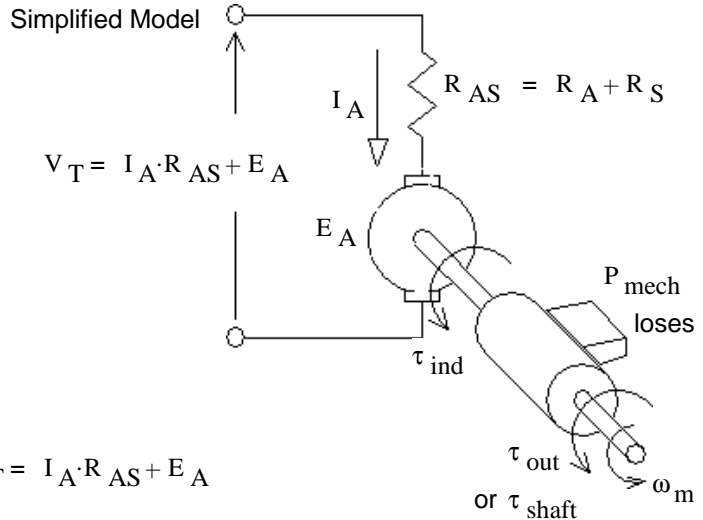
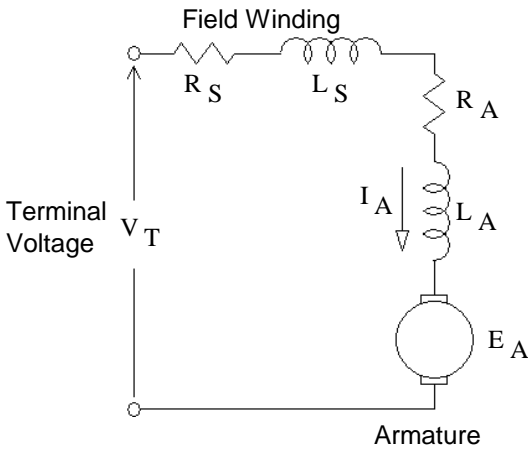

$$\begin{aligned} V_T &= I_A \cdot R_{AS} + E_A \\ &= I_A \cdot R_{AS} + K \cdot \phi \cdot \omega_m \\ &= I_A \cdot R_{AS} + K \cdot (c \cdot I_A) \cdot \omega_m \\ &= I_A \cdot R_{AS} + K \cdot c \cdot I_A \cdot \omega_m \end{aligned}$$

If flux is proportional to field current

$$\phi = c \cdot I_A$$

$$I_A = \frac{\tau_{\text{ind}}}{K \cdot \phi} = \frac{\tau_{\text{ind}}}{K \cdot (c \cdot I_A)}$$

$$I_A^2 = \frac{\tau_{\text{ind}}}{K \cdot c} \quad \text{so: } I_A = \sqrt{\frac{\tau_{\text{ind}}}{K \cdot c}}$$

$$V_T = \sqrt{\frac{\tau_{\text{ind}}}{K \cdot c}} \cdot (R_{AS} + K \cdot c \cdot \omega_m)$$

$$\sqrt{\frac{\tau_{\text{ind}}}{K \cdot c}} = \frac{V_T}{(R_{AS} + K \cdot c \cdot \omega_m)}$$

$$\tau_{\text{ind}} = K \cdot c \cdot \left[ \frac{V_T}{(R_{AS} + K \cdot c \cdot \omega_m)} \right]^2$$

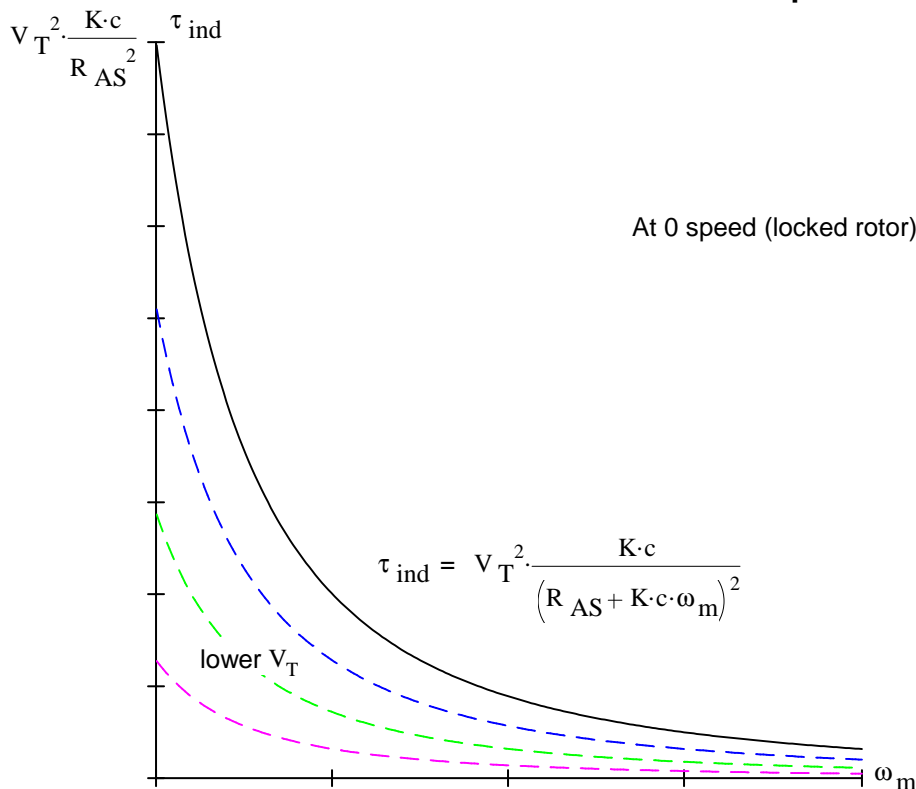

$$\tau_{ind} = K \cdot c \cdot \left[ \frac{V_T}{(R_{AS} + K \cdot c \cdot \omega_m)} \right]^2$$

$$= V_T^2 \cdot \frac{K \cdot c}{(R_{AS} + K \cdot c \cdot \omega_m)^2}$$

At 0 speed (locked rotor):  $\max \tau_{ind} = V_T^2 \cdot \frac{K \cdot c}{R_{AS}^2}$

$R_{AS}$  is usually small, so the maximum induced torque can be huge.

$$\omega_m = \frac{V_T}{K \cdot c \cdot I_A} - \frac{I_A \cdot R_{AS}}{K \cdot c \cdot I_A}$$

$$\omega_m = \frac{V_T}{\sqrt{K \cdot c} \cdot \sqrt{\tau_{ind}}} - \frac{R_{AS}}{K \cdot c}$$

Max speed (no induced torque) is undefined

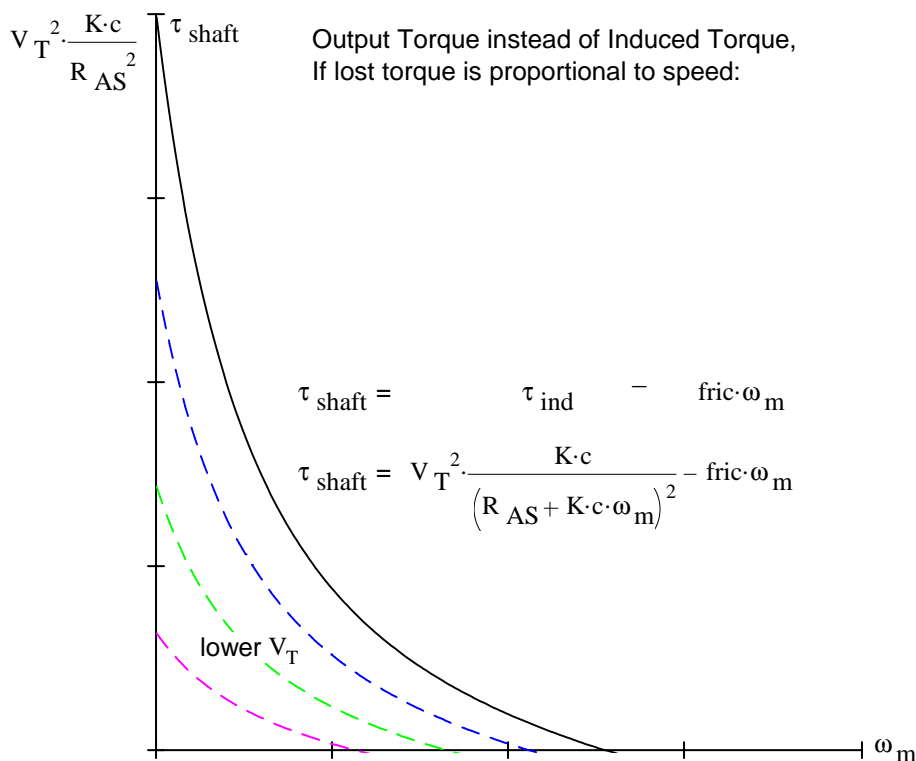

Output Torque instead of Induced Torque, If lost torque is proportional to speed:

$$\tau_{shaft} = \tau_{ind} - fric \cdot \omega_m$$

$$\tau_{shaft} = V_T^2 \cdot \frac{K \cdot c}{(R_{AS} + K \cdot c \cdot \omega_m)^2} - fric \cdot \omega_m$$

$$\tau_{shaft} = \tau_{ind} - fric \cdot \omega_m$$

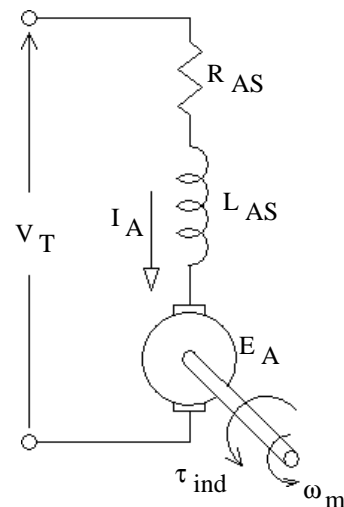

**AC/DC or Universal Motor (Series Excited DC motor)**

Because the same current flows through both the field and the armature, the series-excited motor will turn the same direction even if the current flows the opposite direction-- or even if goes back and forth (AC). These motors are common in AC devices because they can provide a lot of power and torque in small, lightweight motor. They are very common in handheld power tools like drills, saws, grinders, weed eaters, hedge trimmers, etc.. They are also found in vacuum cleaners, blenders and food processors. If you look at the motor of an AC device and see brushes and a commutator, then it is a universal motor.

It is easy to vary the speed of these motors by changing the average voltage, usually with a thyristor-based control similar to a light dimmer.

Universal motors tend to be very noisy.

When used with AC supply, the inductance of the windings becomes important.

**Compounded Motor**

A motor with both shunt and series field windings. Covered in your book, starting on p. 420.

**Adding Load Characteristics**

Returning to the Separately Excited (or permanent Magnet) Motor, let's add Load Torque-Speed curves  $P = \tau \cdot \omega_m$

Load is Power is Proportional to speed

If a power is proportional to speed, then the torque is constant with speed.

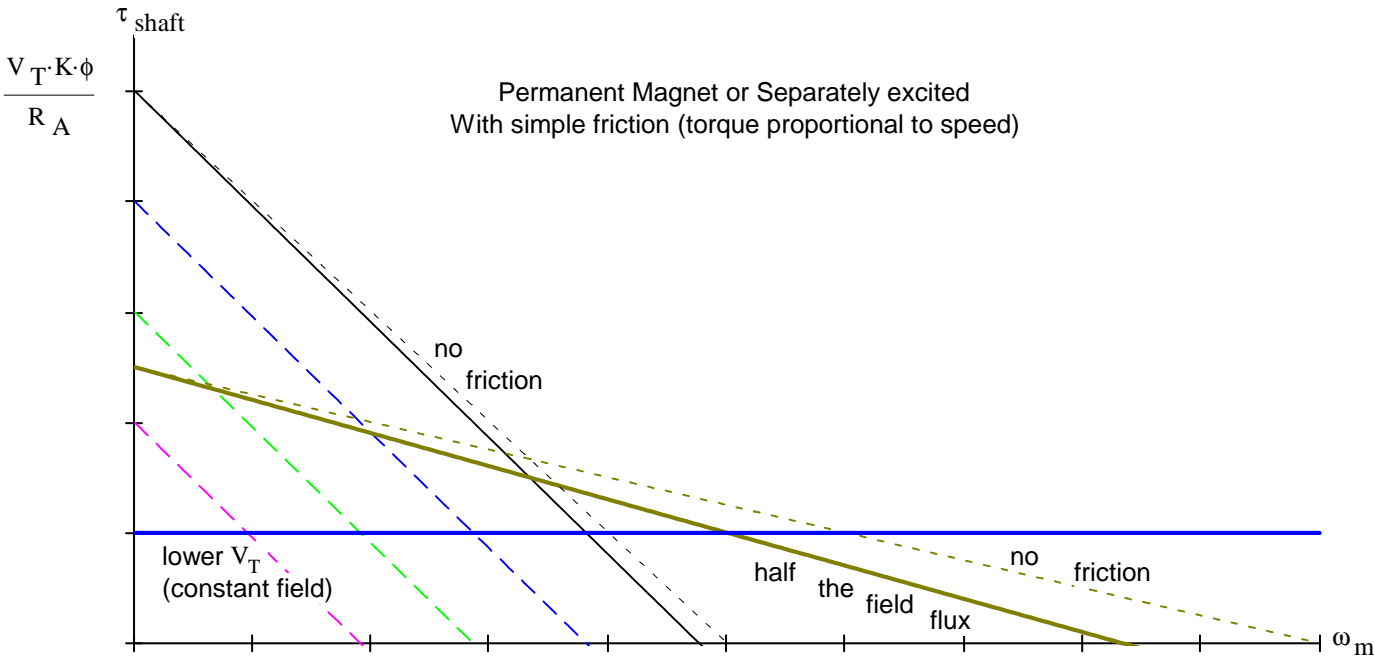
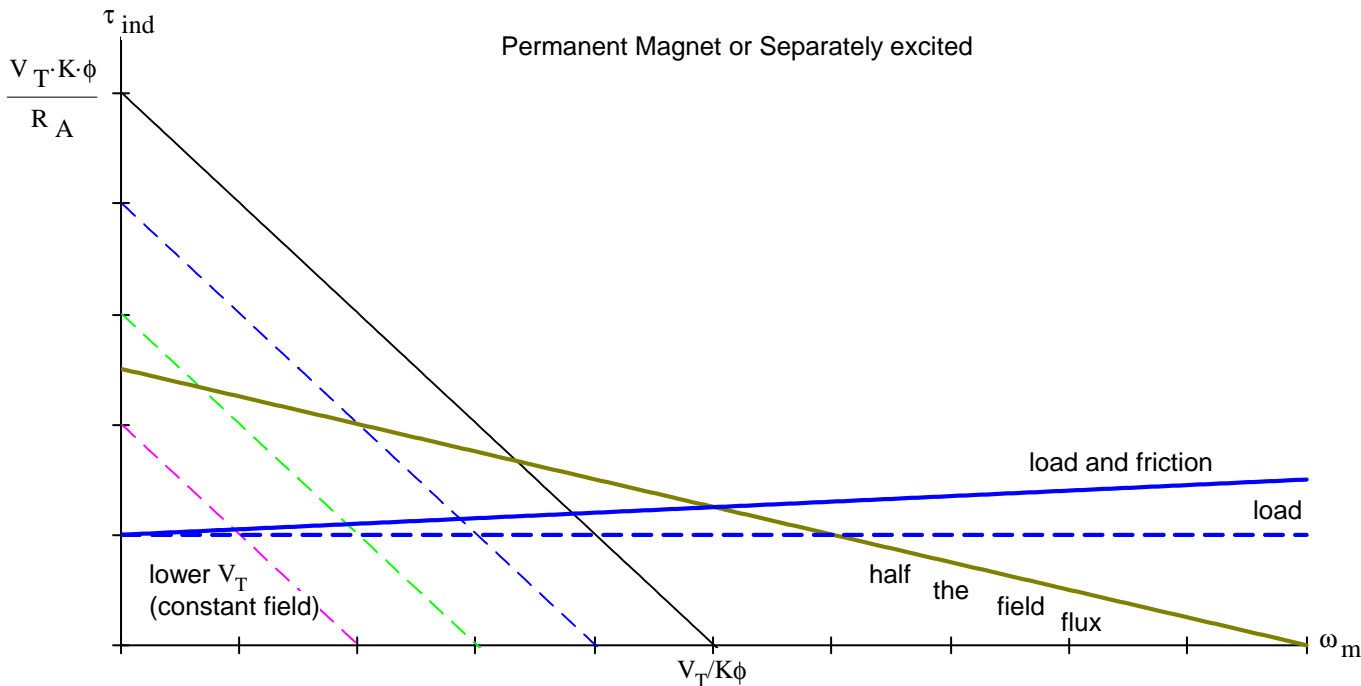



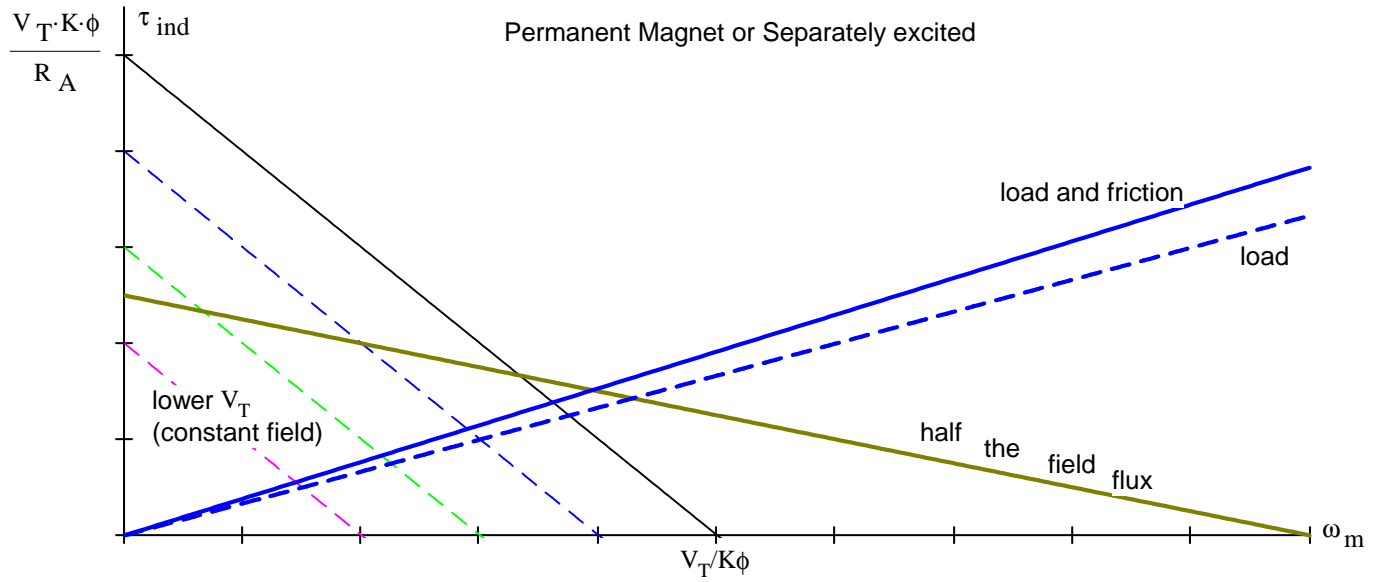

Load Torque is proportional to the square of the speed

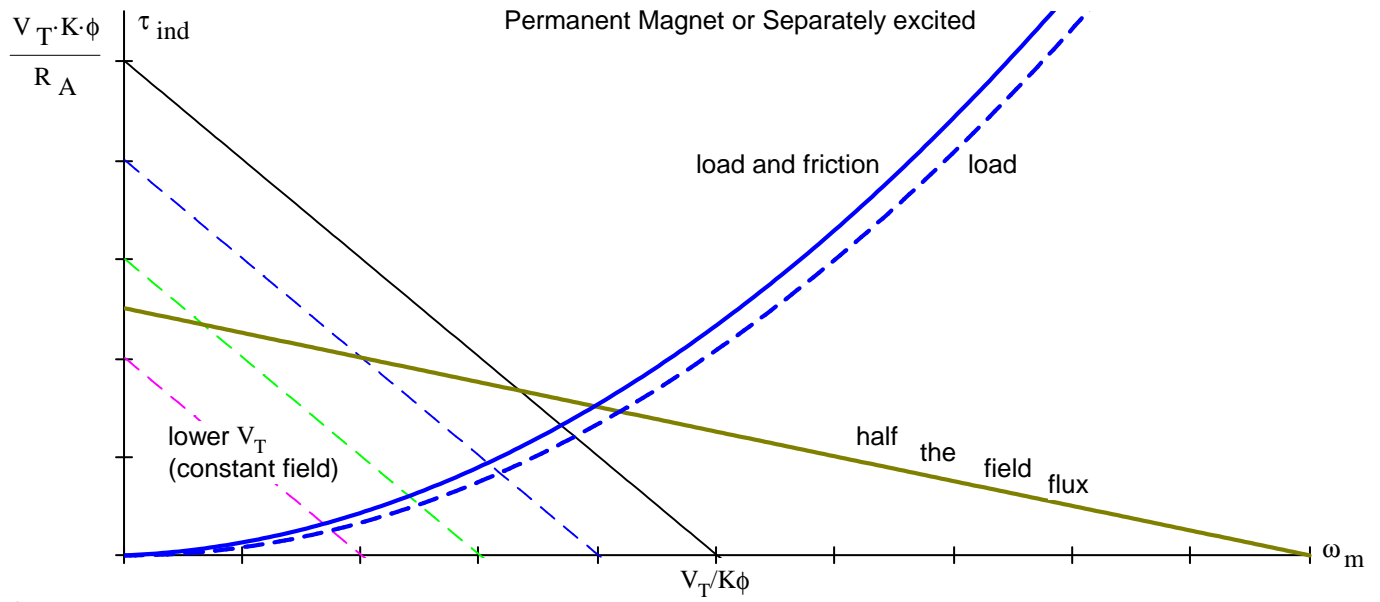

Combination Load

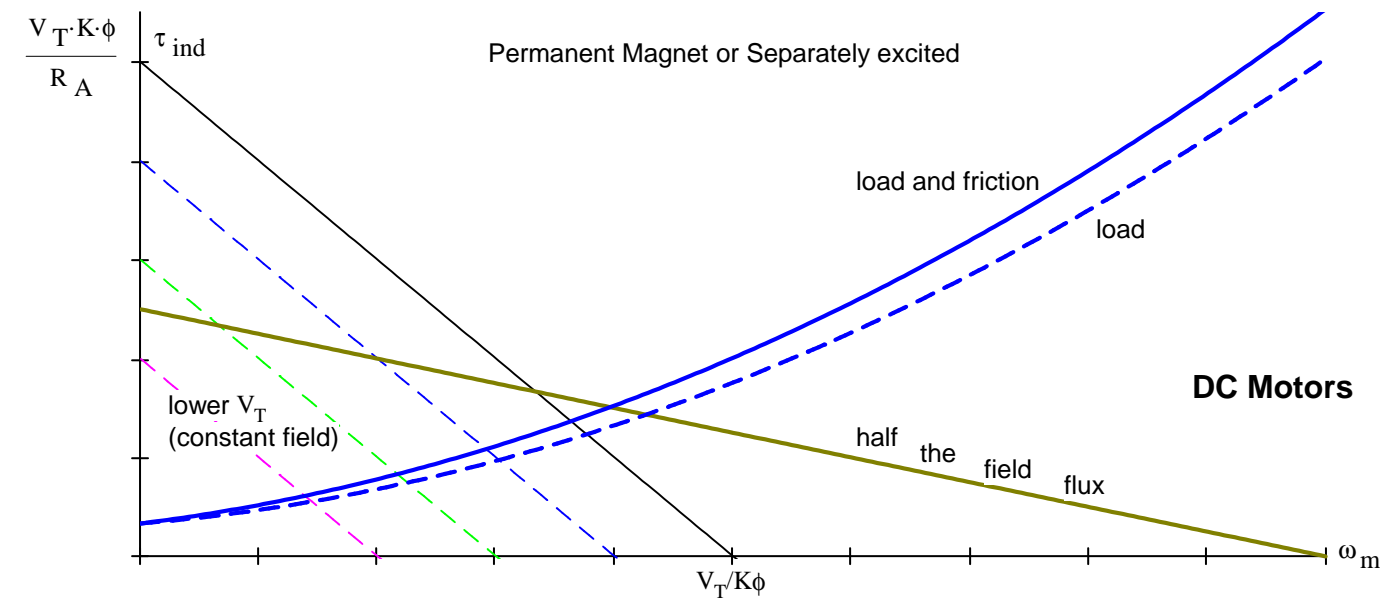

If an output or loss power is constant for all speeds, then the torque is inversely proportional to the speed.

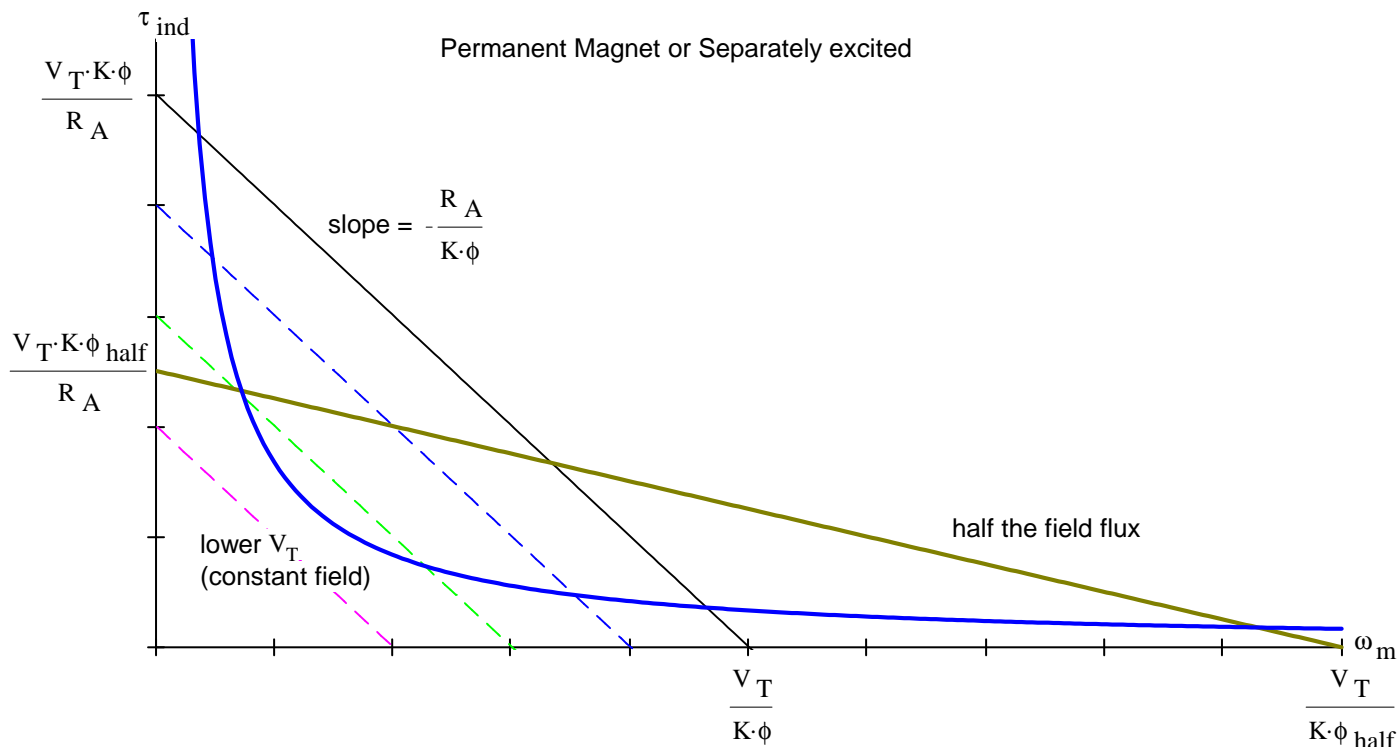

**Brushless DC Motors**

Many Brushless DC motors simply replace the commutator with a rotor position sensor (magnetic (Hall effect), optic, inductive, etc.) and power-electronic circuitry which switches the winding current. The field is usually on the rotor (permanent magnet or a winding fed through slip rings) and the armature windings are stationary. These motors are analyzed just like DC motors with brushes. Many DC fans are made this way.

Many Brushless DC motors are actually 3-phase Synchronous or Induction motors driven by power-electronic circuitry which produces variable-frequency, Pulse-Width-Modulated (PWM), 3-phase power to operate the motor. Actually, they don't have to be 3-phase, as long as they have at least 2 phases. 2, 3, 4, and 6 phases are common.

Brushless motors have some important advantages. They are mechanically simpler and more reliable. They can be operated in environments where the sparking between brushes and commutator would be undesirable or unsafe. They are relatively quiet.

Variable-Frequency, Pulse-Width-Modulated (PWM), 3-phase Power

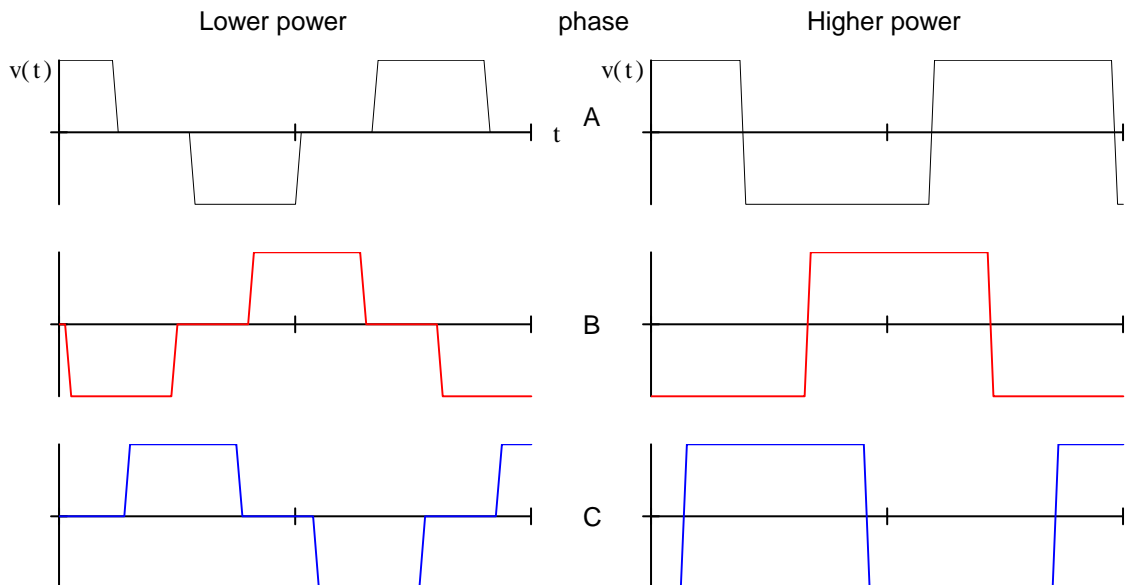

More sample waveforms are shown on the next page.

Higher speed

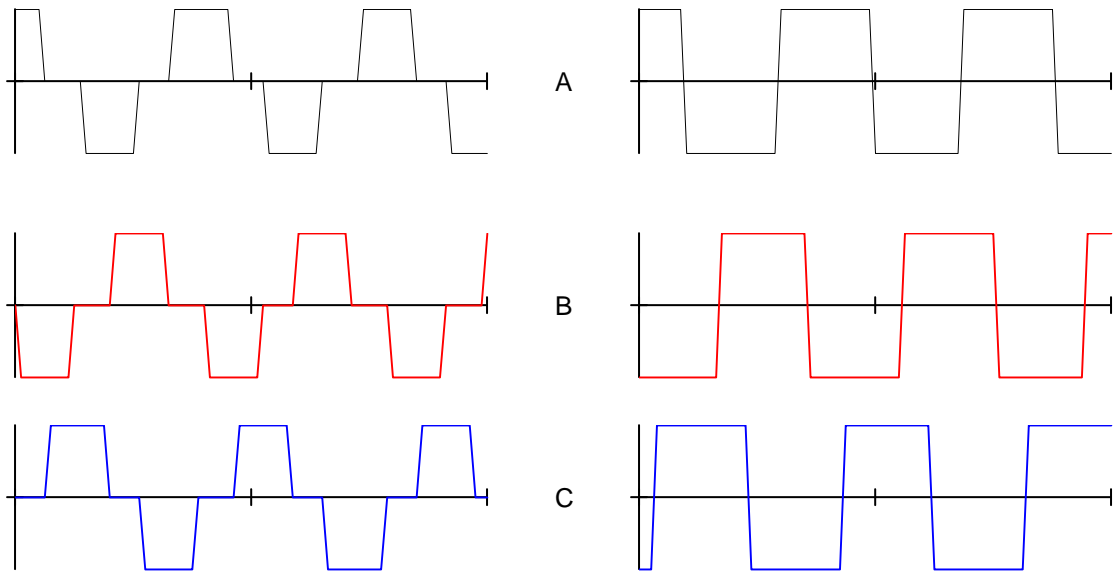

**Pulse Width Modulation (PWM) for speed control**

As you can see by the torque - speed curves above, regulating the terminal voltage,  $V_T$ , is a very effective way to control the speed of a DC motor. Unfortunately, it is often an inefficient process. Pulse Width Modulation, shown here, is a very efficient. It is also more linear, especially at low speeds. The torque - speed curves do not show these non-linearities-- due largely to the difference between static and dynamic friction. (Motors are often a bit sticky at startup.)

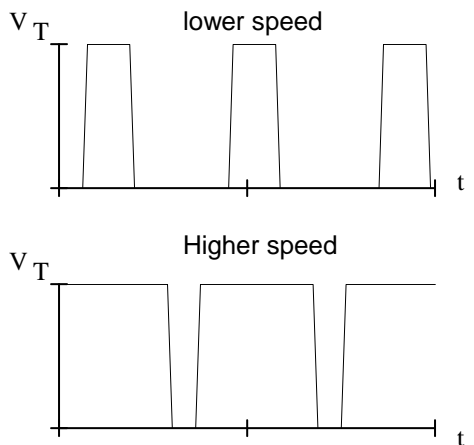

If you do use PWM to control a motor, it is important to remember that the inductance within the windings will not allow the current to go to zero instantaneously. A diode (called a flyback, flywheel, or freewheel diode when used like this) provides a path for the current still flowing through the motor when a pulse is switched off.

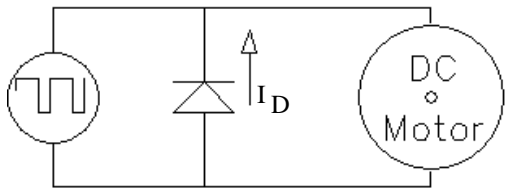

**H-bridge:** Of course, if you want to make the motor turn in both directions you'll need a more complex circuit. Look at the circuit at right, it's has the shape of an H, hence the name. If transistors  $Q_1$  and  $Q_4$  are on, then the current flows as shown, left-to-right through the motor. If transistors  $Q_2$  and  $Q_3$  are on, then the current flows the other way through the motor and the motor will turn in the opposite direction. (The motor here is a permanent-magnet DC motor.) In my circuit, the top two transistors are PNPs, which makes the circuit more efficient. The H-bridge could also be made with all NPNs or with power MOSFET transistors.

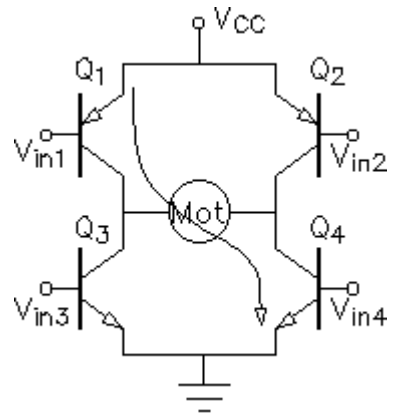

An H-bridge requires four inputs, all operated in concert. To turn on  $Q_1$  and  $Q_4$ , as shown,  $V_{in1}$  would have to be low and  $V_{in4}$  would have to be high. At the same time, the other two transistors would have to be off, so  $V_{in2}$  would have to be high and  $V_{in3}$  would have to be low.

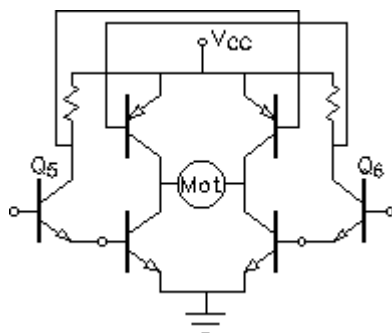

If the control circuit makes a mistake and turns on Q<sub>1</sub> and Q<sub>3</sub> (or Q<sub>2</sub> and Q<sub>4</sub>) at the same time you'll have a toaster instead of a motor driver, at least for a short while.

The circuit at left requires only two inputs. Transistors Q<sub>5</sub> and Q<sub>6</sub> work as *inverters*, when their inputs are high, their outputs are low and vice-versa. The resistors are known as *pull-up* resistors.

The H-bridge should also include flyback diodes.

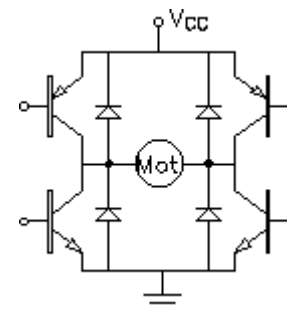

## Regenerative Braking

Electric motors are not limited to converting electrical energy to mechanical. They can also convert energy from mechanical to electrical. If that is done for the purpose of mechanical braking, say in an electric car, then it's called Regenerative Braking. It is a way recover kinetic energy when slowing a moving mass, or potential energy of a mass moving from a higher to a lower elevation. Examples: a car coming to a stop at a traffic light or driving down Parley's canyon. This recovered energy can be used to recharge batteries or simply be wasted in resistors. Electric lawnmowers and some electric drills use this technique to stop the moving parts very quickly for safety.

## Armature Reaction

This phenomenon is well explained in your book, starting on p.372. One effect is a shift of the neutral plane of the field flux. This is a small twisting of the overall North - South orientation and can increase the sparking at the brushes. If the load and rotation direction are known and constant, a small twist of the brush location (in the same direction) will help mitigate the sparking. Interpoles (shown on p. 379) are a better solution. Please note that Fig. 8-11 on p. 374 is for a generator and that  $\omega$  will be in the opposite direction for a motor. The other effect is an overall flux weakening due to core saturation. A few series windings to shore up the flux at high loads can help with this.

## Brush Loss

Sometimes the voltage drop across the brush-commutator connection is also considered. This voltage drop is usually estimated at about 2V for both brushes, regardless of the armature current. (p. 384 in book.)

## Characterizing an Unknown DC motor

For a motor that can be operated as separately excited and as a generator;

**Motor Constant:** Operate the motor as a generator with no load ( $I_A = 0$ ), then  $V_T = E_A$ . Calculate  $K\phi$  from speed and  $E_A$  measurements. You may wish to calculate this at various field currents.

**R<sub>A</sub>:** Hook an electrical load to your still-spinning generator. Adjust input power to return to no-load speed. Measure  $V_T$  and  $I_A$  and calculate  $R_A$ . You may wish to repeat at several loads and take an average.

Alternatively, measure  $V_T$ ,  $I_A$ , and  $\omega$  at 2 different mechanical loads, solve 2 equations for 2 unknowns,  $K\phi$  and  $R_A$ .

$$\begin{aligned} V_{T1} &= I_{A1} \cdot R_A + E_{A1} = I_{A1} \cdot R_A + K \cdot \phi \cdot \omega_1 && \text{You may wish to calculate} \\ V_{T2} &= I_{A2} \cdot R_A + K \cdot \phi \cdot \omega_2 && \text{this at various field currents.} \end{aligned}$$

If you can't measure the rotational speed, but can measure the time required to move something a fixed distance, that time would be inversely proportional to speed:

$$V_{T1} = I_{A1} \cdot R_A + \frac{K \cdot \phi \cdot K_T}{t_1} \qquad V_{T2} = I_{A2} \cdot R_A + \frac{K \cdot \phi \cdot K_T}{t_2} \qquad K_T \text{ is just another constant which is found together with } K\phi \text{ as } K\phi K_T.$$

# ECE 3600 DC Motor Examples

A. Stolp  
11/29/11  
rev 12/1/14

**Ex.1** A 3-hp dc motor has the following nameplate information: 150 V, 1400 rpm, 18 A,  $R_A = 0.8 \Omega$ , and  $R_F = 300 \Omega$ . The field is shunt connected and the 18 A includes the field current. Assume rotational losses are constant.

a) Find the efficiency of the motor at nameplate operation. (Include the field in your calculations)  $1 \text{ hp} = 745.7 \text{ W}$

$$\begin{aligned}
 V_T &:= 150 \text{ V} & n_{FL} &:= 1400 \text{ rpm} & I_{FL} &:= 18 \text{ A} & R_A &:= 0.8 \Omega & R_F &:= 300 \Omega \\
 P_{out} &:= 3 \text{ hp} \cdot \frac{745.7 \text{ W}}{\text{hp}} & P_{out} &= 2.237 \text{ kW} \\
 P_{in} &:= V_T \cdot I_{FL} & P_{in} &= 2.7 \text{ kW} & \eta &= \frac{P_{out}}{P_{in}} = 82.86\%
 \end{aligned}$$

b) Find the rotational losses at nameplate operation.

$$\begin{aligned}
 \text{field current: } I_F &:= \frac{V_T}{R_F} & I_F &= 0.5 \text{ A} \\
 \text{armature full-load current: } I_{AFL} &:= I_{FL} - I_F & I_{AFL} &= 17.5 \text{ A} \\
 E_{AFL} &:= V_T - I_{AFL} \cdot R_A & E_{AFL} &= 136 \text{ V} \\
 P_{conv} &:= E_{AFL} \cdot I_{AFL} & P_{conv} &= 2.38 \text{ kW} \\
 P_{rot} &:= P_{conv} - P_{out} & P_{rot} &= 142.9 \text{ W} & P_{rot} &= 0.192 \text{ hp} \\
 & & & & \text{either answer}
 \end{aligned}$$

c) Find the required current for a developed power of 1.5 hp with  $V_T = 150 \text{ V}$ .

$$\begin{aligned}
 P_{conv} &:= 1.5 \text{ hp} & P_{conv} &= 1.119 \text{ kW} = E_A \cdot I_A \\
 V_T &= E_A + I_A \cdot R_A = \frac{P_{conv}}{I_A} + I_A \cdot R_A & \text{Rearrange} & 0 = R_A \cdot I_A^2 - V_T \cdot I_A + P_{conv} \\
 \text{Solving for } I_A &= \left[ \frac{1}{(2 \cdot R_A)} \cdot \left( V_T \pm \sqrt{V_T^2 - 4 \cdot R_A \cdot P_{conv}} \right) \right] & I_A &:= 7.78 \text{ A} \\
 & & I_S &:= I_A + I_F \\
 & & I_S &= 8.28 \text{ A}
 \end{aligned}$$

d) Find the output power if the developed power is 1.5 hp with  $V_T = 150 \text{ V}$ .

$$P_{out} := P_{conv} - P_{rot} \quad P_{out} = 975.7 \text{ W} \quad P_{out} = 1.308 \text{ hp}$$

e) Find the shaft speed if the developed power is 1.5 hp with  $V_T = 150 \text{ V}$ .

$$\begin{aligned}
 E_A &:= \frac{P_{conv}}{I_A} & E_A &= 143.773 \text{ V} & n &:= \frac{E_A}{E_{AFL}} \cdot n_{FL} & n &= 1480 \text{ rpm} & \text{either answer} \\
 \omega &:= n \cdot \frac{2 \cdot \pi \text{ rad}}{60 \cdot \frac{\text{sec}}{\text{min}} \cdot \text{rev}} & \omega &= 155 \frac{\text{rad}}{\text{sec}}
 \end{aligned}$$

f) A deranged Mouse chews through part of the field winding so that the field current drops and the field flux drops to 40% of its former value. Find the shaft speed if the developed power is still 1.5 hp with  $V_T = 150 \text{ V}$ .

$$\begin{aligned}
 E_A &= K \cdot \phi \cdot \omega & \text{so... } \frac{n}{n_{FL}} &= \frac{\omega}{\omega_{orig}} = \frac{\left( \frac{E_A}{\phi_{new}} \right)}{\left( \frac{E_A}{\phi_{orig}} \right)} = \frac{E_A \cdot \phi_{orig}}{E_A \cdot \phi_{new}} & n_{new} &:= \frac{E_A \cdot 100\%}{E_A \cdot 40\%} \cdot n & n_{new} &= 3700 \text{ rpm} & \text{either answer}
 \end{aligned}$$

g) Find the load torque if the developed power is still 1.5 hp with  $V_T = 150 \text{ V}$ .

$$\tau := \frac{P_{out}}{n_{new} \cdot \left( \frac{2 \cdot \pi \text{ rad}}{60 \cdot \frac{\text{sec}}{\text{min}} \cdot \text{rev}} \right)} \quad \tau = 2.518 \text{ N}\cdot\text{m}$$

## ECE 3600 DC Motor Examples p2

**Ex.2** A dc motor has the following nameplate information: 5-hp, 1200 rpm, Armature: 200 V, 22 A, 1 Ω; Field: 200 V, 1 A

a) Find the rotational losses at nameplate operation.

$$\begin{aligned}
 V_T &:= 200 \cdot \text{V} & n_{FL} &:= 1200 \cdot \text{rpm} & I_{FL} &:= 22 \cdot \text{A} & R_A &:= 1 \cdot \Omega \\
 P_{\text{outFL}} &:= 5 \cdot \text{hp} \cdot \frac{745.7 \cdot \text{W}}{\text{hp}} & P_{\text{outFL}} &= 3.728 \cdot \text{kW} \\
 E_{AFL} &:= V_T - I_{FL} \cdot R_A & E_{AFL} &= 178 \cdot \text{V} \\
 P_{\text{convFL}} &:= E_{AFL} \cdot I_{FL} & P_{\text{convFL}} &= 3.916 \cdot \text{kW} \\
 P_{\text{rotFL}} &:= P_{\text{convFL}} - P_{\text{outFL}} & P_{\text{rotFL}} &= 187.5 \cdot \text{W} & P_{\text{rotFL}} &= 0.251 \cdot \text{hp}
 \end{aligned}$$

b) The load torque is constant (not dependent on speed) and the rotational losses are proportional to speed, find the shaft speed at half the rated armature voltage and full rated field voltage.

$$P = \tau \cdot \omega_m \quad \text{so, if a power is proportional to speed, then the torque is constant.}$$

OR, conversely, if the torque is constant, the power is proportional to speed.

In this case, ALL the power converted is proportional to speed and ALL the the induced torque is constant.

$$P_{\text{conv}} = \frac{n_{\text{new}}}{n_{FL}} \cdot P_{\text{convFL}}$$

One way:  $\tau_{\text{ind}} = K \cdot \phi \cdot I_A$  so, if  $\tau_{\text{ind}}$  and the field current are constant, then  $I_A$  is constant.  $I_A := I_{FL}$

$$\begin{aligned}
 V_T &:= \frac{200 \cdot \text{V}}{2} & E_A &:= V_T - I_A \cdot R_A & E_A &= 78 \cdot \text{V} & n_{\text{new}} &= \frac{E_A}{E_{AFL}} \cdot n_{FL} = 525.8 \cdot \text{rpm}
 \end{aligned}$$

Another solution: recognize that:  $E_A = \frac{n_{\text{new}}}{n_{FL}} \cdot E_{AFL}$  because the field is constant

$$\begin{aligned}
 V_T &= E_A + I_A \cdot R_A = E_A + \frac{P_{\text{conv}}}{E_A} \cdot R_A = E_A + \frac{\frac{n_{\text{new}}}{n_{FL}} \cdot P_{\text{convFL}}}{\frac{n_{\text{new}}}{n_{FL}} \cdot E_{AFL}} \cdot R_A = E_A + \frac{P_{\text{convFL}}}{E_{AFL}} \cdot R_A \\
 E_A &:= \frac{200 \cdot \text{V}}{2} - \frac{P_{\text{convFL}}}{E_{AFL}} \cdot R_A & E_A &= 78 \cdot \text{V} & n_{\text{new}} &= \frac{E_A}{E_{AFL}} \cdot n_{FL} = 525.8 \cdot \text{rpm}
 \end{aligned}$$

c) The torque is constant (like part b)) , find the shaft speed at half the rated voltage for both the armature and field. You may assume that the flux is proportional to the field current.

$$\phi_{100} = \frac{\phi_{200}}{2}$$

One way:  $\tau_{\text{ind}} = K \cdot \phi \cdot I_A$  so, if  $\tau_{\text{ind}}$  is constant and the field current (and flux) is halved, then  $I_A$  is constant at twice the value it used to be.  $I_A := 2 \cdot I_{FL}$   $I_A = 44 \cdot \text{A}$

$$\begin{aligned}
 V_T &:= \frac{200 \cdot \text{V}}{2} & E_A &:= V_T - I_A \cdot R_A & E_A &= 56 \cdot \text{V} & n_{\text{new}} &= \frac{\left( \frac{E_A}{\phi_{100}} \right)}{\left( \frac{E_{AFL}}{\phi_{200}} \right)} \cdot n_{FL} = \frac{2 \cdot E_A}{E_{AFL}} \cdot n_{FL} = 755.1 \cdot \text{rpm}
 \end{aligned}$$

Another solution: recognize that:  $E_A = K \cdot \phi \cdot \omega_m$  is halved because the flux is halved  $E_A = \frac{1}{2} \cdot \frac{E_{AFL}}{n_{FL}} \cdot n_{\text{new}}$

$$\begin{aligned}
 V_T &= E_A + I_A \cdot R_A = E_A + \frac{P_{\text{conv}}}{E_A} \cdot R_A = E_A + \frac{\frac{n_{\text{new}}}{n_{FL}} \cdot P_{\text{convFL}}}{\frac{1}{2} \cdot \frac{n_{\text{new}}}{n_{FL}} \cdot E_{AFL}} \cdot R_A = E_A + 2 \cdot \frac{P_{\text{convFL}}}{E_{AFL}} \cdot R_A \\
 E_A &:= \frac{200 \cdot \text{V}}{2} - 2 \cdot \frac{P_{\text{convFL}}}{E_{AFL}} \cdot R_A & E_A &= 56 \cdot \text{V} & n_{\text{new}} &= \frac{2 \cdot E_A}{E_{AFL}} \cdot n_{FL} = 755.1 \cdot \text{rpm}
 \end{aligned}$$

# ECE 3600 DC Motor Examples p3

d) If the load torque and rotational loss torque are both proportional to speed (most like real life), find the shaft speed when the motor armature is hooked to half the rated voltage. The field is at rated voltage.

$$\tau_{ind} = \frac{n_{new}}{n_{FL}} \cdot \tau_{indFL} \quad P = \tau \cdot \omega_m \quad \text{which leads to:} \quad P_{conv} = \left(\frac{n_{new}}{n_{FL}}\right)^2 \cdot P_{convFL}$$

One way:  $\tau_{ind} = K \cdot \phi \cdot I_A$  so, if  $\tau_{ind}$  is proportional to speed and the field current is constant,

then  $I_A$  is also proportional to speed.  $I_A := \frac{n_{new}}{n_{FL}} \cdot I_{FL}$

$$\begin{aligned} V_T &= E_A + I_A \cdot R_A = E_A + \frac{n_{new}}{n_{FL}} \cdot I_{FL} \cdot R_A = E_A + \frac{n_{new}}{n_{FL}} \cdot I_{FL} \cdot R_A = \frac{n_{new}}{n_{FL}} \cdot E_{AFL} + \frac{n_{new}}{n_{FL}} \cdot I_{FL} \cdot R_A \\ &= \frac{n_{new}}{n_{FL}} \cdot (E_{AFL} + I_{FL} \cdot R_A) = \frac{n_{new}}{n_{FL}} \cdot (200 \cdot V) \quad n_{new} = \frac{100 \cdot V}{200 \cdot V} \cdot n_{FL} = 600 \cdot \text{rpm} \end{aligned}$$

Another solution:  $E_A = \frac{n_{new}}{n_{FL}} \cdot E_{AFL}$  because the field is constant

$$\begin{aligned} V_T &= E_A + I_A \cdot R_A = E_A + \frac{P_{conv}}{E_A} \cdot R_A = E_A + \frac{\left(\frac{n_{new}}{n_{FL}}\right)^2 \cdot P_{convFL}}{\frac{n_{new}}{n_{FL}} \cdot E_{AFL}} \cdot R_A = \frac{n_{new}}{n_{FL}} \cdot E_{AFL} + \frac{\frac{n_{new}}{n_{FL}} \cdot P_{convFL}}{E_{AFL}} \cdot R_A \\ &= \frac{n_{new}}{n_{FL}} \cdot \left( E_{AFL} + \frac{P_{convFL} \cdot R_A}{E_{AFL}} \right) \end{aligned}$$

same as above

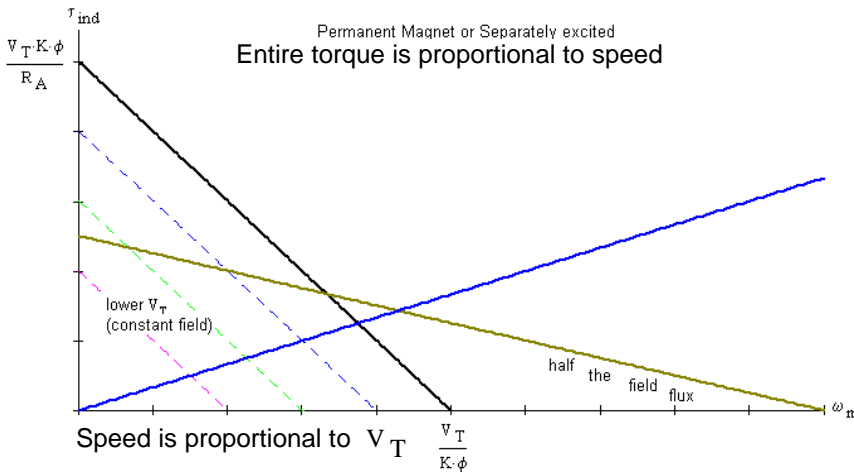

e) If the load torque is proportional to speed and rotational loss torque is constant, find the shaft speed when the motor armature is hooked to half the rated voltage. The field is at rated voltage.

$$\tau_{load} = \frac{n_{new}}{n_{FL}} \cdot \tau_{loadFL} \quad \tau_{loss} = \tau_{lossFL} = \frac{P_{rotFL}}{\omega_{mFL}}$$

$$\tau_{ind} = \frac{n_{new}}{n_{FL}} \cdot \tau_{loadFL} + \tau_{lossFL} = K \cdot \phi \cdot I_A$$

$$I_A = \frac{n_{new}}{n_{FL}} \cdot \frac{\tau_{loadFL}}{K \cdot \phi} + \frac{\tau_{lossFL}}{K \cdot \phi} = \frac{n_{new}}{n_{FL}} \cdot I_{AloadFL} + I_{AlossFL}$$

$$I_{AloadFL} := \frac{P_{outFL}}{E_{AFL}} \quad I_{AloadFL} = 20.947 \cdot A$$

$$I_{AlossFL} := \frac{P_{rotFL}}{E_{AFL}} \quad I_{AlossFL} = 1.053 \cdot A$$

Note:  $I_{AloadFL} + I_{AlossFL} = 22 \cdot A = I_{AFL}$ , exactly as it should be

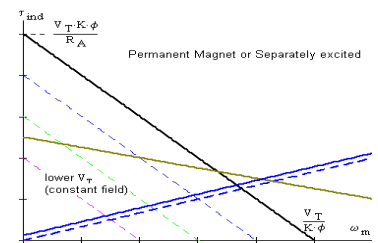

the current can be thought of as composed of two parts

$$V_T = E_A + I_A \cdot R_A = \frac{n_{\text{new}}}{n_{\text{FL}}} \cdot E_{\text{AFL}} + \left( \frac{n_{\text{new}}}{n_{\text{FL}}} \cdot I_{\text{AloadFL}} + I_{\text{AlossFL}} \right) \cdot R_A$$

$$= \frac{n_{\text{new}}}{n_{\text{FL}}} \cdot E_{\text{AFL}} + \frac{n_{\text{new}}}{n_{\text{FL}}} \cdot I_{\text{AloadFL}} \cdot R_A + I_{\text{AlossFL}} \cdot R_A$$

$$V_T - I_{\text{AlossFL}} \cdot R_A = \frac{n_{\text{new}}}{n_{\text{FL}}} \cdot (E_{\text{AFL}} + I_{\text{AloadFL}} \cdot R_A) \quad n_{\text{new}} = \frac{V_T - I_{\text{AlossFL}} \cdot R_A}{E_{\text{AFL}} + I_{\text{AloadFL}} \cdot R_A} \cdot n_{\text{FL}} = 596.8 \cdot \text{rpm}$$

**Ex.3** An unknown, permanent-magnet dc motor is tested at two different loads. In each case the armature voltage is: 24 V.

$$V_T := 24 \cdot \text{V} \quad \text{Load 1: } I_{A1} := 10 \cdot \text{A} \quad n_1 := 163 \cdot \text{rpm} \quad \text{Load 2: } I_{A2} := 30 \cdot \text{A} \quad n_2 := 127 \cdot \text{rpm}$$

a) Find the parameters of this motor.

$$\text{Load 1: } I_{A1} := 10 \cdot \text{A} \quad n_1 := 163 \cdot \text{rpm}$$

$$\omega_1 := n_1 \cdot \left( \frac{2 \cdot \pi \cdot \text{rad}}{60 \cdot \frac{\text{sec}}{\text{min}} \cdot \text{rev}} \right) \quad \omega_1 = 17.069 \cdot \frac{\text{rad}}{\text{sec}}$$

$$V_{T1} = 24 \cdot \text{V} = I_{A1} \cdot R_A + K \cdot \phi \cdot \omega_1$$

$$\text{Load 2: } I_{A2} := 30 \cdot \text{A} \quad n_2 := 127 \cdot \text{rpm}$$

$$\omega_2 := n_2 \cdot \left( \frac{2 \cdot \pi \cdot \text{rad}}{60 \cdot \frac{\text{sec}}{\text{min}} \cdot \text{rev}} \right) \quad \omega_2 = 13.299 \cdot \frac{\text{rad}}{\text{sec}}$$

$$V_{T2} = 24 \cdot \text{V} = I_{A2} \cdot R_A + K \cdot \phi \cdot \omega_2 \quad \text{solve for } R_A = \frac{24 \cdot \text{V} - K \cdot \phi \cdot \omega_2}{I_{A2}}$$

Solve:

$$V_{T1} = 24 \cdot \text{V} = I_{A1} \cdot R_A + K \cdot \phi \cdot \omega_1 \quad \text{substitute in for } R_A$$

$$V_{T1} = 24 \cdot \text{V} = I_{A1} \cdot \left( \frac{24 \cdot \text{V} - K \cdot \phi \cdot \omega_2}{I_{A2}} \right) + K \cdot \phi \cdot \omega_1$$

$$= \frac{I_{A1}}{I_{A2}} \cdot 24 \cdot \text{V} - \frac{I_{A1}}{I_{A2}} \cdot K \cdot \phi \cdot \omega_2 + K \cdot \phi \cdot \omega_1 = \frac{I_{A1}}{I_{A2}} \cdot 24 \cdot \text{V} + K \cdot \phi \cdot \left( \omega_1 - \frac{I_{A1}}{I_{A2}} \cdot \omega_2 \right)$$

$$K \cdot \phi = \frac{24 \cdot \text{V} - \frac{I_{A1}}{I_{A2}} \cdot 24 \cdot \text{V}}{\left( \omega_1 - \frac{I_{A1}}{I_{A2}} \cdot \omega_2 \right)} = 1.266 \cdot \text{V} \cdot \text{sec}$$

$$R_A = \frac{24 \cdot \text{V} - K \cdot \phi \cdot \omega_2}{I_{A2}} = \frac{24 \cdot \text{V} - (1.266 \cdot \text{V} \cdot \text{sec}) \cdot \omega_2}{I_{A2}} = 0.239 \cdot \Omega$$

b) The rotational loss torque is proportional to speed.

Find the parameters of this motor.

Notice that the induced torque is NOT part of the calculation above. Therefore it doesn't matter how it is split between the loss and the load. The calculations are exactly the same.



- A shunt-connected dc motor operates from 24 V and has an armature resistance of 0.30. The armature current is 10 A, the field current is 1 A, and the speed is 1200 rpm. The rotational losses are 5% of the output power.
  - Find the input power.
  - Find the output power in horsepower.
  - Find the efficiency of this motor.
  - Find the machine constant  $K\phi$ .
  - Find the no-load speed in rpm, assuming rotational losses remain approximately the same as at full load..
  - Find the approximate no-load speed in rpm, assuming rotational losses are zero ( $I_A = 0$ ). Is this a good estimate of the actual no-load speed?
- A shunt-excited dc motor has the following nameplate information: 1.5 hp, 1750 rpm, 180 V, 7.3 A armature current, 1.05- $\Omega$  armature resistance, 0.55 A field current. Assume constant rotational losses in this problem.  $V_T := 180\text{-V}$ 
  - Find the rotational losses. (Since they are assumed to be constant, calculate at nameplate operation.)
  - Find the developed torque at full load.
  - Determine the no-load speed.
  - If the field winding connection malfunctioned so that the field flux dropped to a residual value of 15% of the original value, what would be the new no-load shaft speed. Is this speed likely to damage the motor?

## ECE 3600 homework # DC2

Due: Fri, 11/11/22

d2

- A separately excited, dc motor has the following nameplate information: 1.5-hp, 2500 rpm, Armature: 150 V, 9 A,  $R_A = 0.8\ \Omega$ ,  $L_A = 12\text{ mH}$ ; Field:  $V_F = 150\text{ V}$ , and  $R_F = 250\ \Omega$ . Assume rotational losses are constant. Consider the motor to be shunt connected to 150 V for parts a) through e).
  - Find the total losses of the motor at nameplate operation.
  - Find the rotational losses at nameplate operation
  - Find the the developed power if the load drops to 1.2 hp.
  - Find the required current if output power is 1.2 hp.
  - Find the shaft speed if output power is 1.2 hp.
  - Find the required Input voltage for a no-load speed of 2800 rpm.  $V_T = ??$
  - Can you attain a no load speed of 2800 rpm by some other method with  $V_T = 150\text{ V}$ . (Note: You may assume that the field flux is proportional to the field current.)  $V_F = ??$
- A 5-hp, separately excited, 160-V dc motor has 0.25- $\Omega$  armature resistance and 90-W rotational loss at the nameplate speed of 600 rpm. The field is also connected to 160 V and its current is 0.5 A.
  - What is the developed torque at the nameplate output power of 5 hp?
  - What is the efficiency at 5 hp out, including field losses?
  - If the load torque and rotational loss torque are both constant (not dependent on speed), find the shaft speed when the motor armature is hooked to half the rated voltage, 80V. (Field is left connected to 160V.)
  - If the load torque and rotational loss torque are both proportional to speed, find the shaft speed when the motor armature is hooked to half the rated voltage, 80V. (Field is left connected to 160V.)

**Answers**

1. a) 264-W      b) 200-W = 0.268·hp      c) 75.6%      d) 0.167·V·sec      e) 1364-rpm      f) 1371-rpm      yes
2. a) 139-W      b) 6.86·N·m      c) 1820-rpm      d) 12133-rpm      The rotor may fly apart.

**DC2**

1. a) 321-W      b) 167-W      c) 1.06-kW      d) 7.37-A      e) 2523-rpm      f) 161-V      g) Reduce  $V_F$  to 140 V
2. a) 60.8·N·m      b) 92%      c) 288-rpm      d) 300-rpm

1. 17.31. A 12.6-V. permanent-magnet-field dc motor is used to power a window lift in an automobile. The motor requires 10.2 A and runs at 1180 rpm when lifting the window, but requires only 7.6 A and turns at 1220 rpm when lowering the window (with reversed voltage, current, and direction of rotation).
- a) Determine the armature resistance,  $R_A$ . Try to figure this out on your own as a test of your engineering ability to combine basic principles and math to solve a problem. There is a hint down with the answers if you fail your test.  
Ans:  $0.145\Omega$  Avoid looking at the answers below to avoid seeing hints to part b) so you can test yourself again.
- b) Lifting an object at a constant rate, without friction, would require a constant torque from the motor ( $\tau_{\text{lift}}$ ), regardless of speed. Lowering the same object, the motor would turn in the opposite direction and the same torque would look backwards ( $-\tau_{\text{lift}}$ ). It would actually help turn the motor and we would expect the motor to act as a generator and expect a negative  $I_A$ . This system, however, has a lot of friction and rotational losses. Assume friction and rotational losses are proportional to speed and hence can be represented by a constant loss torque ( $\tau_{\text{friction}}$ ). The motor has to provide this torque regardless of direction. In each direction the motor torque ( $\tau_{\text{ind}}$ ) is simply the sum of these two torques.

Determine the torque required to lift the window ( $\tau_{\text{lift}}$ ), excluding the effects of friction. Hints by the answers, if needed.

2. 17.35. An engineer purchased a dc motor with a permanent-magnet field. The nameplate gives 90 V and 9.2 A but does not give the rated power. The engineer applied 90 V to the unloaded motor and measured the input current (0.5 A) and speed (1843 rpm). The engineer then loaded the motor mechanically until the current reached 9.2 A and measured the speed (1750 rpm), voltage was maintained at 90 V. The engineer assumed that rotational losses were constant, and determined from these data the output power at nameplate load. What was the result? Hints by the answers, if needed.

3. 17.37. The circuit at right shows a series-excited motor. Ignore rotational losses. Hints by the answers, if needed.

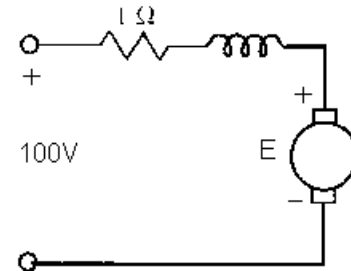

- a) Find the current for 1 hp out.
- b) If the load torque is decreased by a factor of 2, what is the new current, assuming no magnetic saturation?
4. The following measurements are taken on a series-wound (series-excited) AC/DC motor.
- a) A number of static measurements are taken with an ohmmeter as the rotor is moved to different positions. Because of the brushes, these measurements vary a bit. Take the average to get  $R_{AS}$ .
- 2.21- $\Omega$     1.96- $\Omega$     1.88- $\Omega$     2.13- $\Omega$     2.20- $\Omega$     1.92- $\Omega$     1.90- $\Omega$     2.04- $\Omega$
- b) At  $V_T := 10\text{-V}$  and locked rotor  $\tau_{\text{max}} := 01.56\text{-N}\cdot\text{m}$  Find  $K\cdot c$   
Hints by the answers, if needed.
- c) At  $V_T := 100\text{-V}$  and no load, the motor spins at a maximum speed of  $n_{\text{max}} := 1000\text{-rpm}$   
If torque lost due to friction is proportional to speed:  $\tau_{\text{frict}} = \text{fric}\cdot\omega_m$  find the constant:  $\text{fric}$   
Hints by the answers, if needed.
- d) Use Matlab, a spreadsheet, or the program or method of your choice to calculate and plot the shaft torque-speed curve of this motor. The horizontal scale should be in rpm, vertical in Nm.  $V_T := 100\text{-V}$   
Make sure your plotting method can accommodate added lines in the next problem.  
Make sure the scaling is appropriate to see both ends of the plot. Suggested scale: 0-160Nm and 0-1000rpm.  
Print your plot and attach it to your homework.

## ECE 3600 homework DC3 p.2

5. a) The motor of the previous problem is coupled to a constant-power load.  $P_{load} := 1 \cdot hp$        $P_{load} = 745.7 \cdot W$

Replot your torque-speed curve from previous problem and add the load's torque-speed curve. If you have a "divide by zero" problem it is probably just one point on the load line, you may skip plotting that point or just substitute a large number, above the scale of your plot.

Keep the same x-y scaling you used in the previous problem, but you may want to print a larger plot so that you can more accurately see where the lines cross. The crossing points are typically stable steady-state operation points.

b) If the motor were allowed to spin up to it's no-load speed before applying the load, what speed and torque would the system settle on? Find the torque and speed numbers from your graph as best you can. Show this point on your paper print. I suggest you just do this by hand.

c) If the load were connected to the motor before the motor started, what speed and torque would the system settle on? Find the numbers and show the point, like you did before.

d) Is this a realistic load? If yes, give an example of a load where the torque is inversely proportional to speed.

6. On the next page.

### Answers

1. a) Hint: write  $V_T = E_A + I_A \cdot R_A$  for both cases, giving you 2 equations & 3 unknowns ( $E_{Aup}$ ,  $E_{Adn}$ , and  $R_A$ ).

Then use the fact that  $E_A$  is proportional to speed for the 3rd equation.      ans:  $0.145 \cdot \Omega$

b) Hints:  $\tau_{up} = \tau_{lift} + \tau_{friction} = \frac{P_{convup}}{\omega_{up}}$        $\tau_{dn} = -\tau_{lift} + \tau_{friction}$        $\tau_{lift} = \frac{\tau_{up} - \tau_{dn}}{2} = 0.117 \cdot Nm$       ans:

2. Hints: First find  $R_A$  as in problem 1a),  $P_{rot} = P_{conv}$  at no load.      ans:  $739 \cdot W = 0.991 \cdot hp$ ,  
 3. a) Hint: Found the same way as regular DC motor.      ans:  $8.12 \cdot A$        $741 \cdot W$  if you estimate  $E_{Anl} = V_{tnl}$ ,  $R_A$  not needed.

b) Hint: Torque is proportional to the current squared      ans:  $5.74 \cdot A$

4. a)  $2.03 \cdot \Omega$

b) Hints: See the DC motor notes, Series-Excited motors, torque - speed curve.  $\omega = 0$       ans:  $0.0643 \cdot \frac{N \cdot m}{\Lambda^2}$

c) Hints: See the DC motor notes, Series-Excited motors, 2<sup>nd</sup> torque - speed curve.  $\tau_{shaft} = 0$       ans:  $0.08 \cdot N \cdot m \cdot sec$

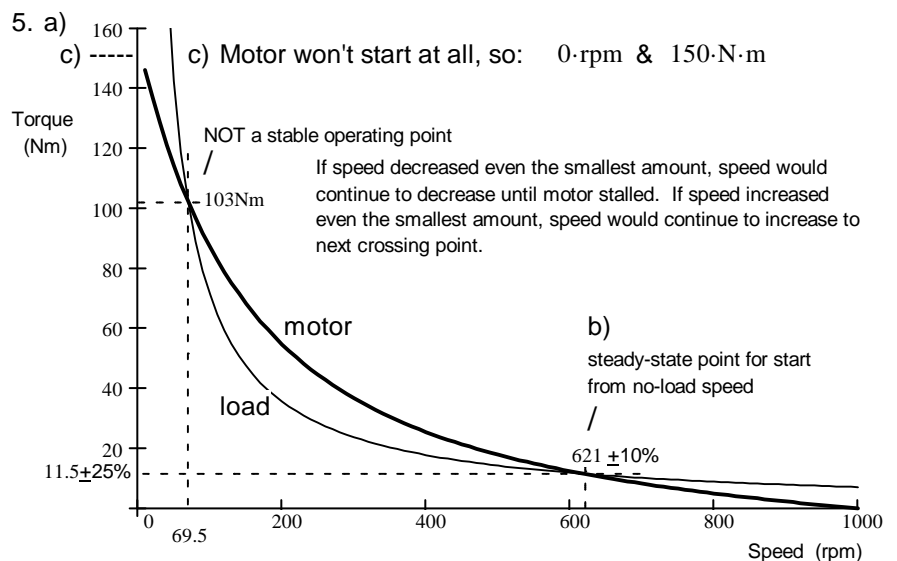
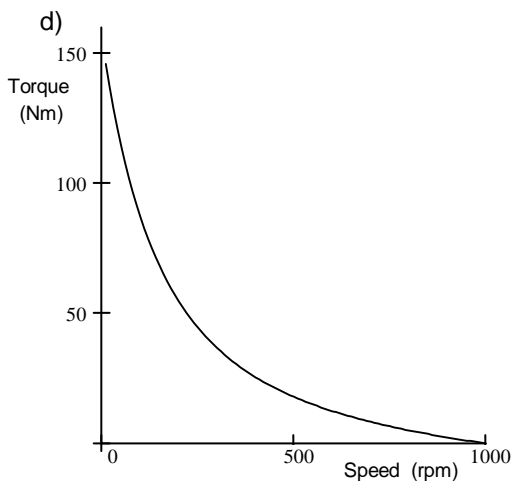

6. a) Load 1 280-rpm 2.2-N·m Constant-torque, power proportional to speed. Ex: lift object without friction.

Load 2 238-rpm 3.3-N·m Torque proportional to speed, power proportional to speed squared. Ex: simple friction, no lift.

Load 3 155-rpm 6.5-N·m Mix of two types above. Ex: elevator, crane, etc..

Load 4 189-rpm 5-N·m Like load 3, but friction isn't linear. Ex: water pump or fan if initial torque were smaller.

answers could be  $\pm 3rpm$  and/or  $\pm 0.2Nm$

c) Series-excited DC

6. A motor's torque-speed curve is shown below (dark line). Several load curves are also shown

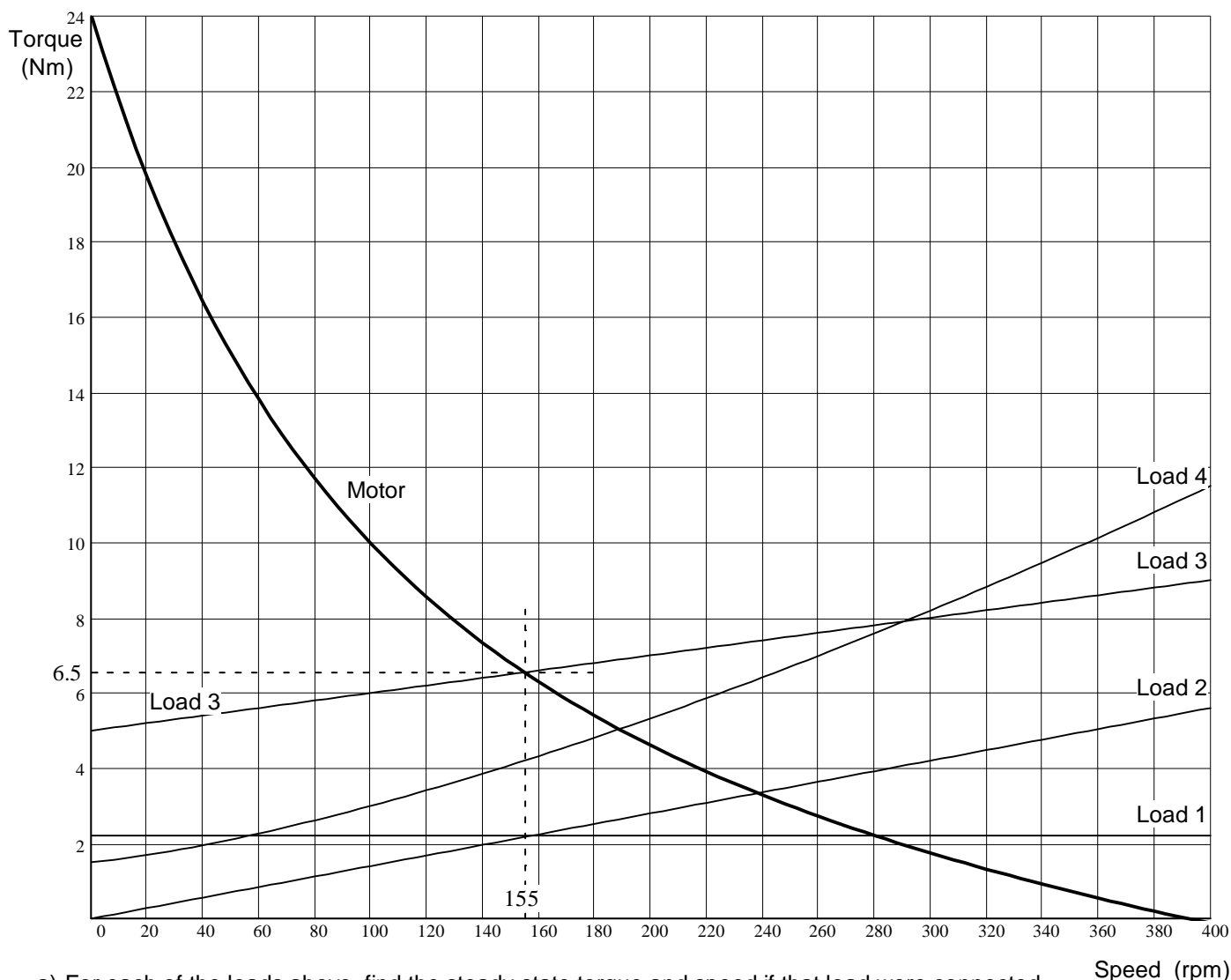

a) For each of the loads above, find the steady-state torque and speed if that load were connected to the motor. Show your work on the plot above and hand it in with your homework. I've found the answers for Load 3.

Load 1 \_\_\_\_\_

Load 2 \_\_\_\_\_

Load 3     155-rpm     6.5·N·m

Load 4 \_\_\_\_\_

b) For each of the loads, say what kind of load it is and/or give an example.

Load 1

Load 2

Load 3

Load 4