

# ECE 3600 Single-Phase Induction Motors

A single-phase winding on the stator of an induction motor.

So, does this motor have a torque-speed curve??

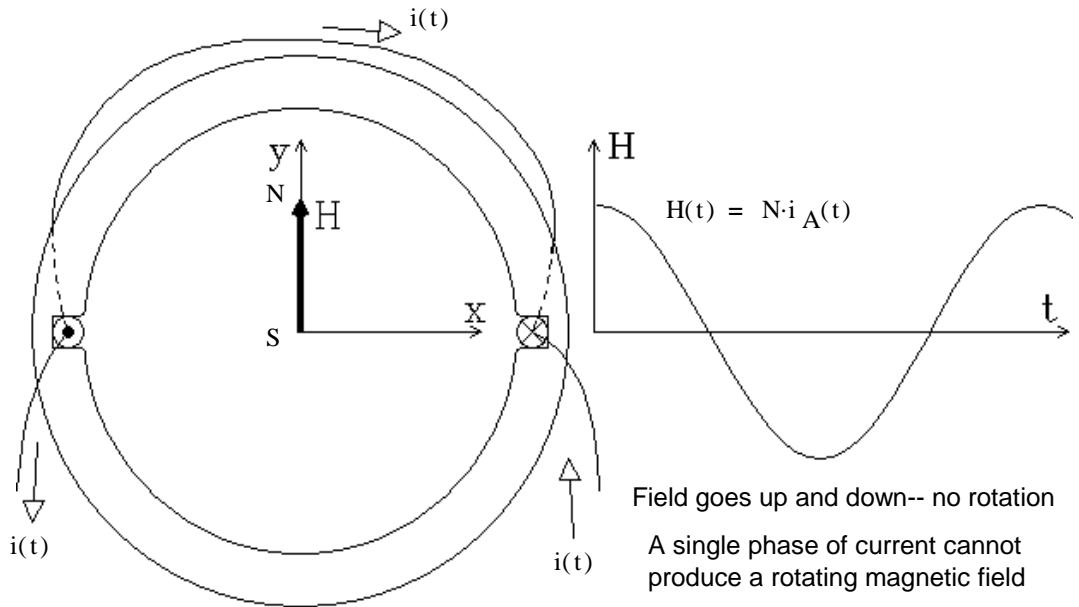

Yes. Think of the magnetic intensity vector,  $H$ , as being made up of two vectors half as large and rotating in opposite directions. The green (CCW) vector and the blue (CW) vectors shown below add up to be the  $H$  vector.

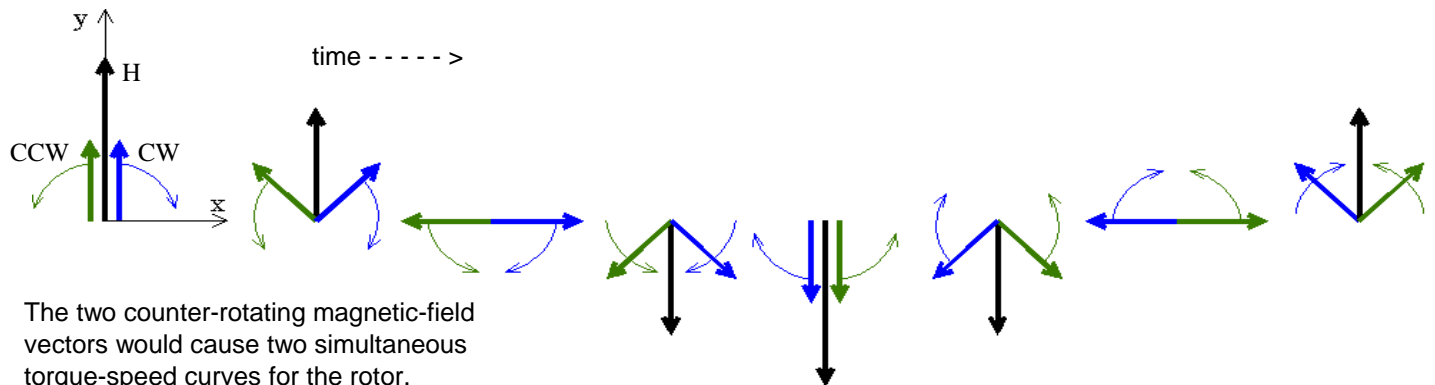

The two counter-rotating magnetic-field vectors would cause two simultaneous torque-speed curves for the rotor.

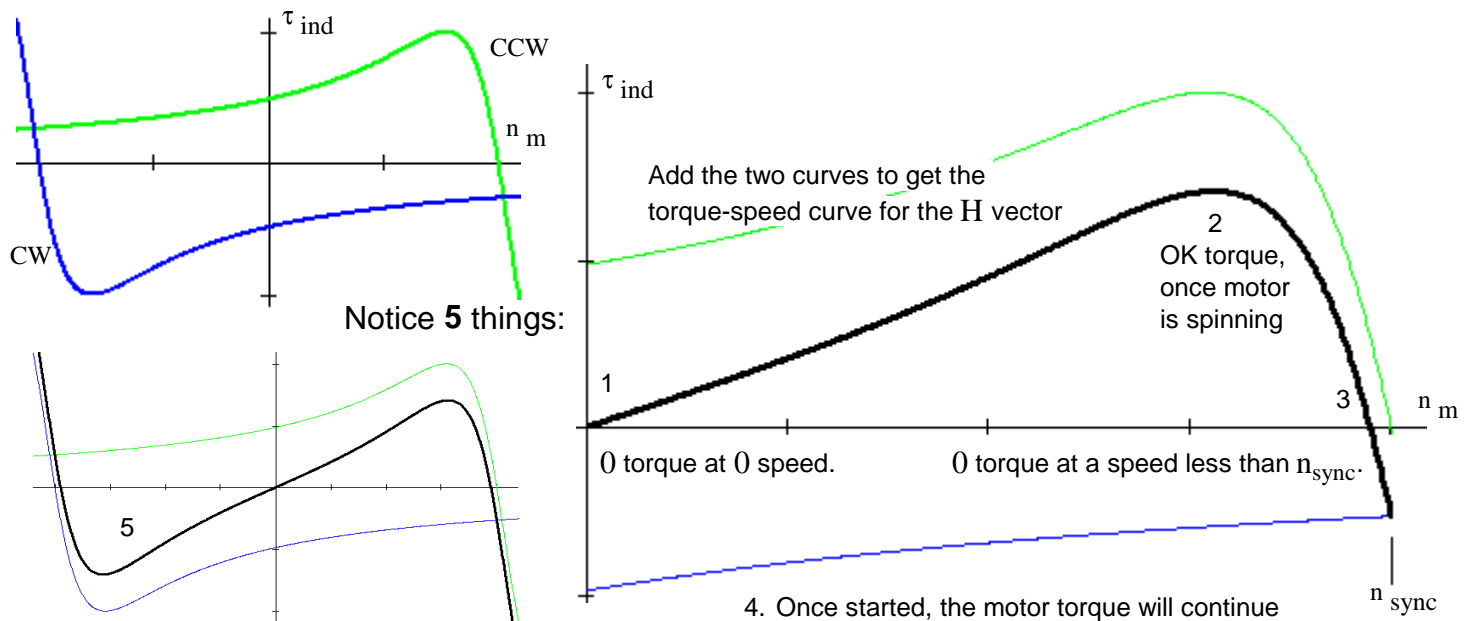

5. Motor will spin equally well in reverse, if you can just get it started that way.

Think back to the first lab. Isn't that exactly what we saw in that lab?

So, how can we get this motor started?

Adding a second winding might help, but only if the timing (phase) of  $i(t)$  and  $i_2(t)$  are not the same. If the phase of  $i(t)$  and  $i_2(t)$  are the same, then there is no net field rotation. But, if  $i_2(t)$  can be delayed a little from  $i(t)$ , then there would be some net field rotation in the counter-clockwise (CCW) direction. Alternatively, if  $i_2(t)$  could lead  $i(t)$ , then there would be some net field rotation in the clockwise (CW) direction.

Unless you want to manually start the motor...

The motor NEEDS a second winding to get started, AND the phase of the two currents NEED to be different in order to get some net rotating magnetic field. No net rotating field -- means no starting torque.

Each winding can be modeled in the same way as a single phase of a 3-phase winding.

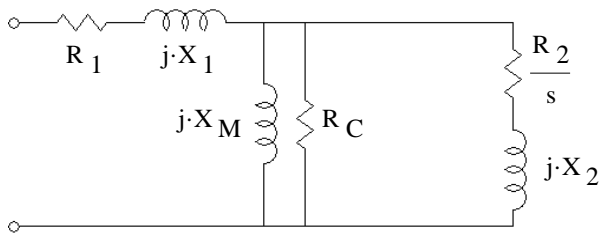

Sometimes the windings may be shown as something that looks like a single inductor, but it MUST have both resistance AND inductance.

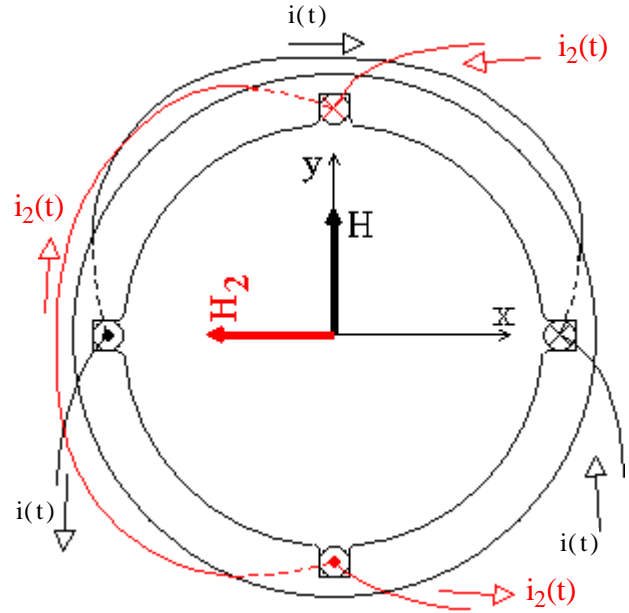

But are often shown as a single resistor and inductor.

The values of the resistor and inductor would only be valid at one value of slip ( $s$ ).

The two windings may also be shown like this, to indicate that they are placed at a  $90^\circ$  angle to one another with respect to the rotor.

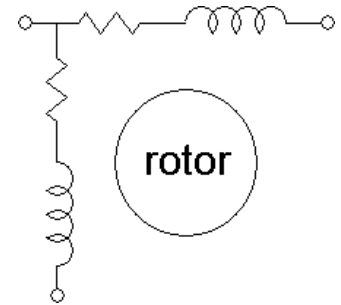

(Note: the actual angle would be less if it's not a 2-pole motor)

### Capacitor-Run Motor

A capacitor is hooked up in series with one winding of the motor.

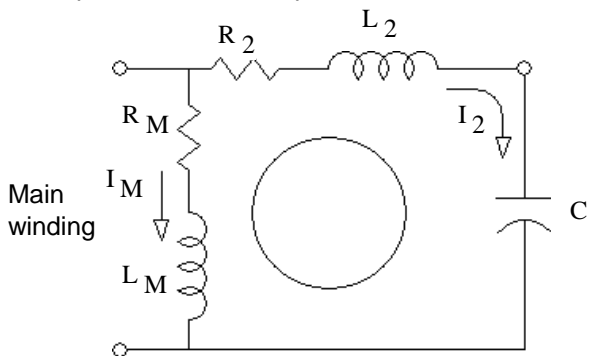

Ideally, choose a capacitor so that the current through the second winding ( $I_2$ ) leads the current through the main winding ( $I_M$ ) by  $90^\circ$ . Unfortunately, that will only be possible at one motor speed (or slip).

A better, but more complex and expensive system.

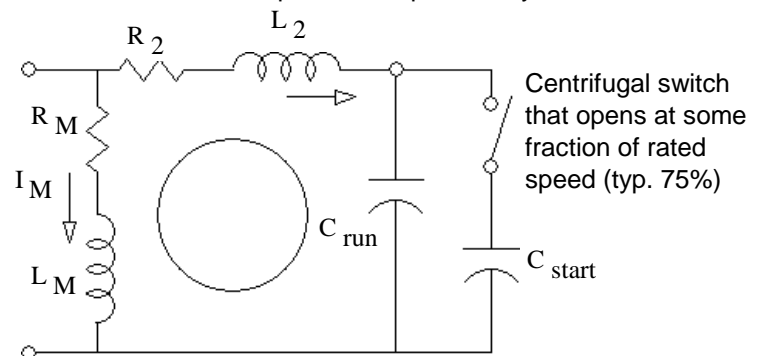

Now choose  $C_{run}$  to be ideal at normal operation and  $C_{run} + C_{start}$  to be ideal at startup.

## Capacitor-Start Motor

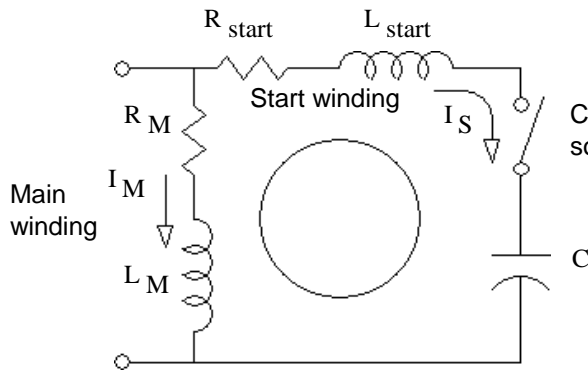

Centrifugal switch that opens at some fraction of rated speed (typ. 75%)

Ideally, choose a capacitor so that the current through the second winding ( $I_S$ ) leads the current through the main winding ( $I_M$ ) by  $90^\circ$  at startup ( $s = 1$ ).

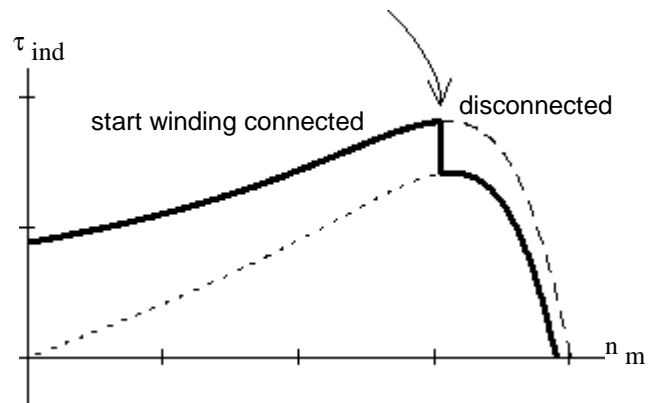

## Capacitor Calculation For a specific slip

$$Z_M = R_M + j \cdot \omega L_M$$

$$I_M = \frac{V_T}{Z_M}$$

$V_T$  is the terminal voltage

$$Z_S = R_S + j \cdot \omega L_S$$

$$I_S = \frac{V_T}{Z_S}$$

$$\phi = \angle I_{SC} - \angle I_M = \arg(I_{SC}) - \arg(I_M)$$

$$Z_S + Z_C = R_S + j \cdot \left( \omega L_S - \frac{1}{\omega C} \right)$$

$$I_{SC} = \frac{V_T}{Z_S + Z_C}$$

$$= \arg(Z_M) - \arg(Z_S + Z_C)$$

$$= \operatorname{atan} \left( \frac{\omega L_M}{R_M} \right) - \operatorname{atan} \left[ \frac{\omega L_S - \frac{1}{\omega C}}{R_S} \right]$$

Where  $\phi$  is the angle difference between the currents (or impedances).

## Motor Starting Torque

Proportional to the current magnitudes and the sine of the phase angle difference between the winding currents.

$$(I_M \cdot I_S \cdot \sin(\phi))$$

## Split-Phase Motor

The run winding has a large inductance and little resistance.

The start winding has little inductance and lots of resistance.

Cheap, but can only get about  $30^\circ$  of phase difference between currents

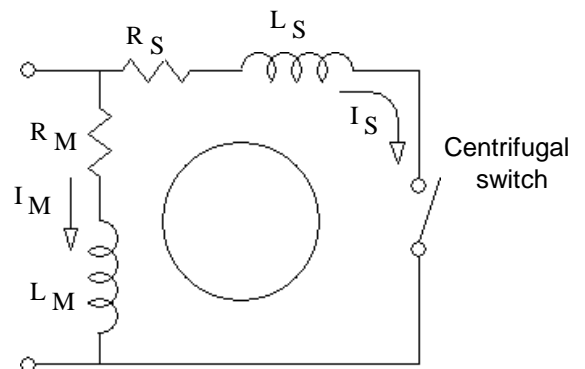

**Start Direction:** Reverse the leads to either of the windings to get the motor to start in the opposite direction.

## ECE 3600 Single-Phase Induction Motor Examples

A.Stolp  
11/18/19  
rev

**Ex. 1** From Fin F11. A Single-phase, 1/3-hp, 120-V split-phase motor draws 5 A in its main winding, and 3 A in its start winding when it is first switched on. The two currents lag the supply voltage by 40° and 15° respectively.

a) Find the initial start-up current (magnitude) and power.

$$\omega := 377 \frac{\text{rad}}{\text{sec}}$$

$$\mathbf{I}_{\mathbf{L}} := 5 \cdot \text{A} \cdot e^{-j \cdot 40 \cdot \text{deg}} + 3 \cdot \text{A} \cdot e^{-j \cdot 15 \cdot \text{deg}} \quad |\mathbf{I}_{\mathbf{L}}| = 7.822 \cdot \text{A} \quad \arg(\mathbf{I}_{\mathbf{L}}) = -30.672 \cdot \text{deg}$$

$$P_{\text{start}} := 120 \cdot \text{V} \cdot |\mathbf{I}_{\mathbf{L}}| \cdot \cos(\arg(\mathbf{I}_{\mathbf{L}})) \quad P_{\text{start}} = 807.36 \cdot \text{W}$$

b) To improve this motor, you want to add a capacitor in series with the start winding so that currents will be 90° out of phase with each other. Find the value of the required capacitor.

The original: 
$$\mathbf{Z}_{\text{start}} := \frac{120 \cdot \text{V}}{3 \cdot \text{A} \cdot e^{-j \cdot 15 \cdot \text{deg}}} \quad \mathbf{Z}_{\text{start}} = 38.637 + 10.353j \cdot \Omega$$

The start winding current should now lead the voltage by 50°.

$$X_{\text{start}} + X_{\text{C}} = -38.637 \cdot \Omega \cdot \tan(50 \cdot \text{deg}) = -46.046 \cdot \Omega$$

$$X_{\text{C}} := -46.046 \cdot \Omega - 10.353 \cdot \Omega \quad X_{\text{C}} = -56.399 \cdot \Omega = -\frac{1}{\omega \cdot \text{C}} \quad \text{C} := \frac{1}{-X_{\text{C}} \cdot \omega} \quad \text{C} = 47 \cdot \mu\text{F}$$

c) The new start winding current is about 2 A. The motor starting torque is proportional to the sine of the angle between the winding currents. It is also proportional to the magnitudes of the currents. How much bigger is the starting torque with the additional capacitor?

$$\frac{(2 \cdot \text{A}) \cdot (5 \cdot \text{A}) \cdot \sin(90 \cdot \text{deg})}{(3 \cdot \text{A}) \cdot (5 \cdot \text{A}) \cdot \sin(40 \cdot \text{deg} - 15 \cdot \text{deg})} = 1.577$$

**Ex. 2** From Fin F12. A 1/4-hp, 120-V, 60-Hz, single-phase, capacitor-run, induction motor has two identical windings set 90° apart in the motor housing. Each winding draws 3 A at 30° lag when the rotor is locked and 1.5 A at 40° lag when the motor is running at its rated speed.

a) Find the ideal capacitor to place in series with one of the windings at startup.

Note: the ideal capacitor would create the ideal phase difference between the winding currents.

$$\mathbf{Z}_{\text{start}} := \frac{120 \cdot \text{V}}{3 \cdot \text{A} \cdot e^{-j \cdot 30 \cdot \text{deg}}} \quad \mathbf{Z}_{\text{start}} = 34.641 + 20j \cdot \Omega$$

$$X_{\text{start}} + X_{\text{C}} = -34.641 \cdot \Omega \cdot \tan(60 \cdot \text{deg}) = -60 \cdot \Omega$$

$$X_{\text{C}} := -60 \cdot \Omega - 20 \cdot \Omega \quad X_{\text{C}} = -80 \cdot \Omega = -\frac{1}{\omega \cdot \text{C}} \quad \text{C} := \frac{1}{-X_{\text{C}} \cdot \omega} \quad \text{C} = 33.2 \cdot \mu\text{F}$$

b) Find the ideal capacitor to place in series with one of the windings at rated speed.

$$\mathbf{Z}_{\text{run}} := \frac{120 \cdot \text{V}}{1.5 \cdot \text{A} \cdot e^{-j \cdot 40 \cdot \text{deg}}} \quad \mathbf{Z}_{\text{run}} = 61.284 + 51.423j \cdot \Omega$$

$$X_{\text{run}} + X_{\text{C}} = -61.284 \cdot \Omega \cdot \tan(50 \cdot \text{deg}) = -73.035 \cdot \Omega$$

$$X_{\text{C}} := -73.035 \cdot \Omega - 51.423 \cdot \Omega \quad X_{\text{C}} = -124.458 \cdot \Omega = -\frac{1}{\omega \cdot \text{C}} \quad \text{C} := \frac{1}{-X_{\text{C}} \cdot \omega} \quad \text{C} = 21.3 \cdot \mu\text{F}$$

c) Find a compromise capacitor to place in series with one of the windings. Choose this capacitor to make the current magnitude in the two windings exactly the same at rated speed. (Don't worry about the phase angles.)

$$X_{\text{C}} := -2 \cdot 51.423 \cdot \Omega \quad X_{\text{C}} = -102.846 \cdot \Omega = -\frac{1}{\omega \cdot \text{C}} \quad \text{C} := \frac{1}{-X_{\text{C}} \cdot \omega} \quad \text{C} = 25.8 \cdot \mu\text{F}$$

d) Find the input power at rated speed with the compromise capacitor in place.

$$\mathbf{I}_{\mathbf{L}} := 1.5 \cdot \text{A} \cdot e^{-j \cdot 40 \cdot \text{deg}} + 1.5 \cdot \text{A} \cdot e^{j \cdot 40 \cdot \text{deg}} \quad |\mathbf{I}_{\mathbf{L}}| = 2.298 \cdot \text{A} \quad \arg(\mathbf{I}_{\mathbf{L}}) = 0 \cdot \text{deg}$$

$$P_{\text{start}} := 120 \cdot \text{V} \cdot |\mathbf{I}_{\mathbf{L}}| \cdot \cos(\arg(\mathbf{I}_{\mathbf{L}})) \quad P_{\text{start}} = 275.8 \cdot \text{W}$$

Answer the following questions in your textbook, p.348.

- 7-11. Why is it necessary to reduce the voltage applied to an induction motor as electrical frequency is reduced?
- 7-12. Why is terminal voltage speed control limited in operating range?
- 7-13. What are starting code letters? What do they say about the starting current of an induction motor?
- 7-14. What information is learned in a locked-rotor test?
- 7-15. What information is learned in a no-load test?

Solve the following problems in your textbook.

1. 7-1. A DC test is performed on a 460-V,  $\Delta$ -connected, 100-hp induction motor. If  $V_{DC} = 21V$  and  $I_{DC} = 72A$ , what is the stator resistance  $R_1$ ? Why is this so?

Hint: Think about (draw) a single DC source hooked to a  $\Delta$  connection.

2. 7-18. A 208-V, six-pole, Y-connected, 25-hp, design class B induction motor is tested in the laboratory, with the following results:

No load: 208 V, 22.0A, 1200 W, 60 Hz

Locked rotor: 24.6 V, 64.5 A, 2200W, 15 Hz

DC: 13.5 V, 64A

Find the equivalent circuit of this motor, ~~and plot its torque-speed characteristic curve.~~

3. 7-24. Answer the following questions about a 460-V,  $\Delta$ -connected, two-pole, 100-hp, 60-Hz, starting code letter F, induction motor:
- What is the maximum current current that this machine's controller must be designed to handle?
  - If the controller is designed to switch the stator windings from a  $\Delta$ -connection to a Y-connection during starting, what is the maximum starting current that the controller must be designed to handle? (This means that the motor will start Y-connected and later switch to the normal  $\Delta$ .)
  - If a 1.25:1 step-down autotransformer starter is used during starting, what is the maximum starting current that it must be designed to handle? (This is instead of the Y-connected start)

The following problems are not from your textbook

4. How can you reverse the direction of rotation of a capacitor-start motor? That is, reverse the direction it starts.
- Reverse the leads to the capacitor.
  - Reverse the positions of the capacitor and the start (second) winding.
  - Reverse the leads to the main winding.
  - Reverse the leads to the start winding.
  - Reverse the leads to both the main and the start windings.

Will this also work for a capacitor-run motor?

5. At the instant of starting a 1/4-hp 120-V split-phase motor draws 5 A in its starting winding, and 8 A in its main winding. The two currents lag the supply voltage by  $20^\circ$  and  $45^\circ$ , respectively. At startup, determine:
- the line current and power factor, and
  - the in-phase components of the currents with the supply voltage.
6. A capacitor is added in series with the starting winding of the motor in the previous problem. The starting current in the start winding now leads the voltage by  $40^\circ$ . The main winding remains as is.
- With this added capacitor, determine at the instant of starting the line current and the power factor.
  - Compare the line current to that calculated in problem 4
  - The motor starting torque is proportional to the sine of the angle between the winding currents. It is also proportional to the magnitudes of the currents. How much bigger is the starting torque with the additional capacitor?

### ECE 3600 homework # Ind3 p2

7. Measured at 60 Hz, the two windings of a single-phase motor have the following impedances:

main winding:  $Z_m := (3.1 + 2.9j) \cdot \Omega$

starter winding:  $Z_s := (7.0 + 3.1j) \cdot \Omega$

Find the capacitor size that will produce the phase angle  $\alpha = 90^\circ$ .

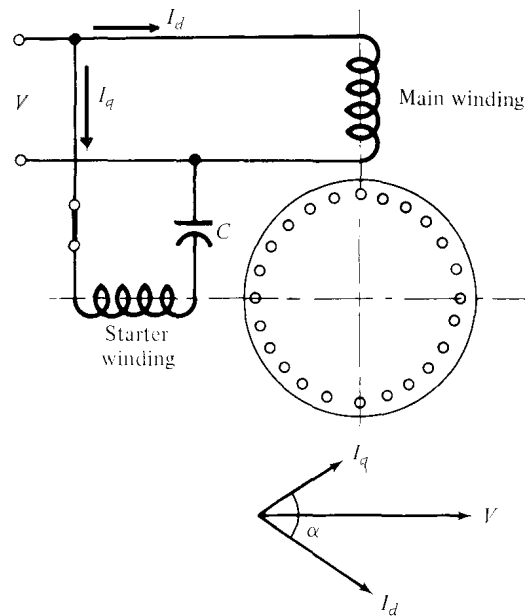

8. A 1/3-hp, 120-V, 60-Hz, single-phase, capacitor-run, single-phase induction motor has two identical windings set  $90^\circ$  apart in the motor housing. Each winding draws 6.8 A at  $20^\circ$  lag when the rotor is locked and 2 A at  $40^\circ$  lag when the motor is running at its rated speed. This is with no added capacitors, so the motor would have to be started by hand.

- Find the ideal capacitor to place in series with one of the windings at startup. Note: the ideal capacitor would create the ideal phase difference between the winding currents.
- Find a different capacitor to replace the capacitor of part a). Choose this capacitor to make the current magnitude in the two windings exactly the same at rated speed. (Don't worry about the phase angles.)
- The ideal capacitor to get  $90^\circ$  phase difference at rated speed is  $28.4 \mu\text{F}$ . What would be a good compromise between the answer of part b) and  $28.4 \mu\text{F}$ ? Choose a nice round number.
- If the motor had a centrifugal switch which opens at half the rated speed, devise a design to achieve approximate conditions of parts a) and c). Find all capacitor values needed. Choose a nice round numbers. (Remember, cap values add when in parallel.)

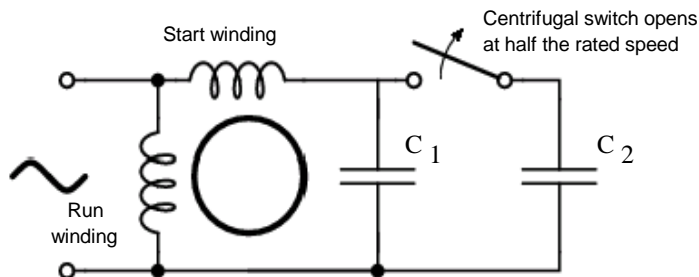

### Answers

1.  $0.437 \cdot \Omega$

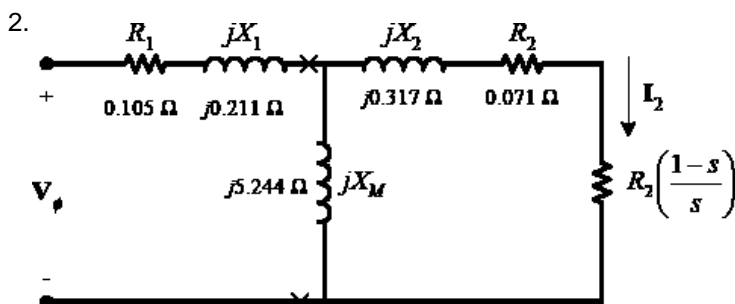

3. a)  $703 \cdot \text{A}$     b)  $234 \cdot \text{A}$     c)  $450 \cdot \text{A}$

4. c & d    yes

5. a)  $12.708 \cdot \text{A}$      $0.815$  lagging

b)  $4.70 \cdot \text{A}$      $5.66 \cdot \text{A}$

6. a)  $9.29 \cdot \text{A}$      $0.945$  lagging

b) Almost 27% less    c) 1.92 times bigger

7.  $251 \cdot \mu\text{F}$     8. a)  $51.41 \cdot \mu\text{F}$     b)  $34.4 \cdot \mu\text{F}$

c)  $30 \cdot \mu\text{F}$     d)  $C_1 := 30 \cdot \mu\text{F}$      $C_2 := 20 \cdot \mu\text{F}$