

Induction Motors

Three-Phase, Rotating Magnetic Field

The magnetic flux inside the motor rotates at the "synchronous" speed.

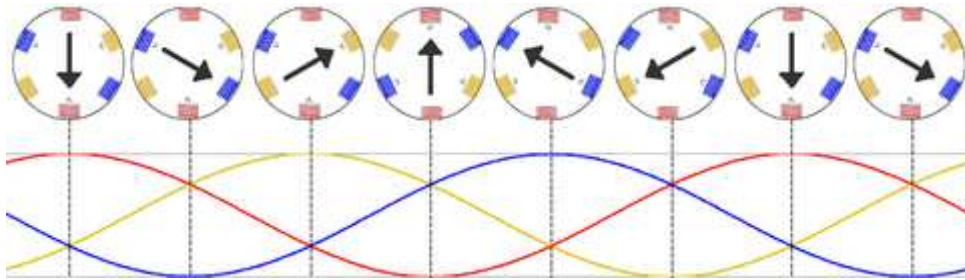

2-pole, 3-phase stator winding and the rotating flux



simplified 2-pole

If you place a rotor with a magnet or electromagnet inside this rotating magnetic flux, it would rotate at the synchronous speed. This is the way a synchronous motor works.

If you place a rotor with wire loops (typically a squirrel-cage winding) inside this rotating magnetic flux, voltages and currents would be induced in these windings as in the secondary of a transformer. These currents would, in turn, create a magnetic field which would tend to follow the rotating magnetic field and cause the rotor to turn. It would NOT rotate at the synchronous speed because the closer it gets, the smaller the induced currents in the rotor windings. (If the rotor ever did turn at the synchronous speed, the induced currents and torque would be zero.) This is the way an induction motor works.

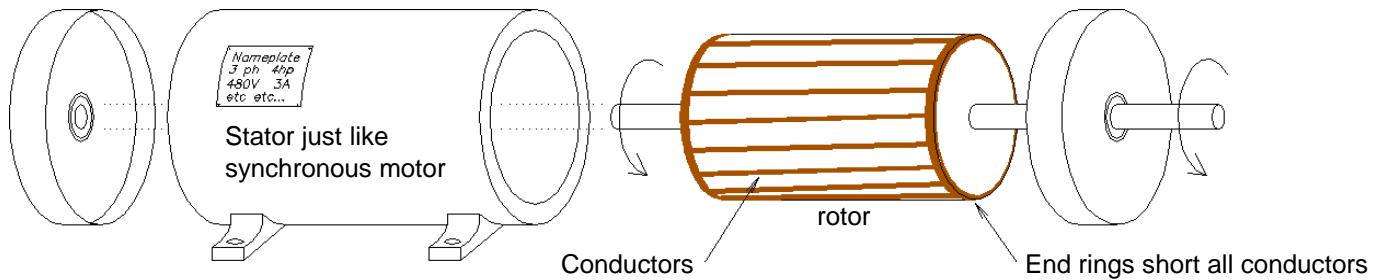

A typical rotor of an induction motor includes a number of thick conductors called "rotor bars". Voltage is induced in these bars because the rotor normally turns at speed which is slower than the synchronous speed (the speed of the rotating flux caused by the stator windings). By Lenz's law, the resulting currents will flow in a direction to oppose the change that caused them. Thus the interaction between the induced current and the rotating flux provides the motor torque.

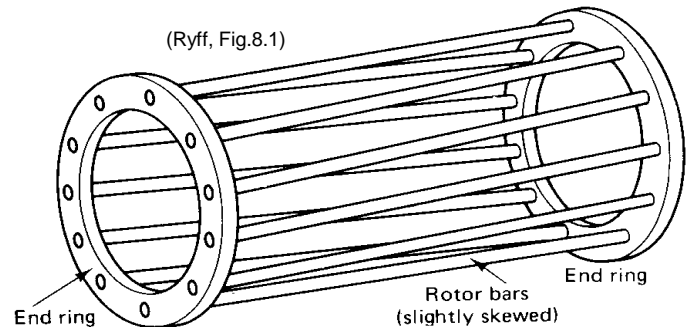

For more pictures of induction motors and a far more detailed description of how they work, see chapter 7 in your textbook.

Slip (s)

The synchronous speed is the speed of the rotating magnetic field caused by the stator windings.

$$\omega_{sync} = \frac{4 \cdot \pi \cdot f}{N_{poles}} \frac{\text{rad}}{\text{sec}} \quad f = \text{electrical frequency (60Hz in US)} \quad \omega = n \cdot \left(2 \cdot \pi \cdot \frac{\text{rad}}{\text{rev}} \right) \cdot \left(\frac{\text{min}}{60 \cdot \text{sec}} \right) \text{ rpm}$$

$$n_{sync} = \frac{120 \cdot f}{N_{poles}} \quad n \text{ denotes rpm}$$

Slip (s) indicates how much slower the rotor is spinning.

$$n_m = \text{the mechanical speed of the rotor} = (1 - s) \cdot n_{sync} \quad n_{slip} = n_{sync} - n_m = s \cdot n_{sync}$$

$$\text{slip } s = \frac{n_{slip}}{n_{sync}} = \frac{n_{sync} - n_m}{n_{sync}}$$

$$f_{rot} = s \cdot 60 \cdot \text{Hz} = \text{frequency of voltages induced on the rotor}$$

A typical torque-speed curve

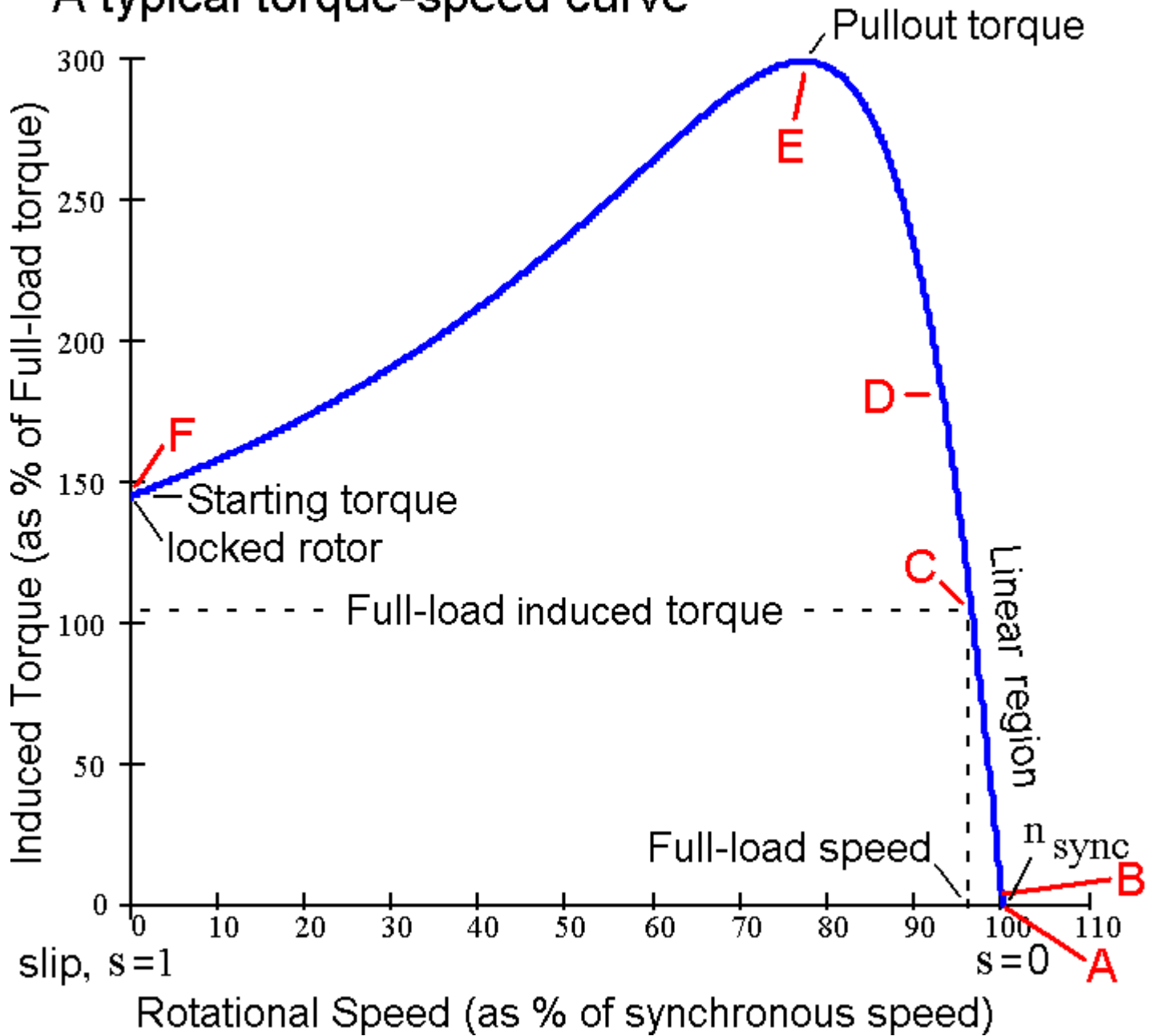

Look at the typical torque-speed curve of an induction motor shown above. It shows induced torque as a function of the rotor speed. Induced torque is the torque produced by the motor internally. It includes both the torque needed to overcome mechanical losses inside the motor and the torque needed to rotate whatever mechanical load may be coupled to the motor shaft (the shaft torque). The internal losses are friction and wind resistance (windage). The windage can be significant since most rotors include some rudimentary fan blades to move cooling air through the motor.

Let's look at some specific points and areas on the curve (Letters A through F, going backwards over the curve):

A The Motor cannot operate here. $n_m = n_{sync}$ $s = 0$ $f_{rot} = 0\text{-Hz}$ $\tau_{ind} = 0\text{-N}\cdot\text{m}$

The rotor is spinning at the synchronous speed, the speed of the rotating magnetic field produced by the stator windings. The rotor conductors do not experience any change in the magnetic field, so have no induced voltage or current and the induced torque on the rotor is zero. The motor CANNOT run at this speed because it cannot overcome the friction within the motor. It MUST run at a slower speed.

B No-load Condition $P_{out} = 0$ $\tau_{shaft} = 0$ $\tau_{ind} = \tau_{mech_loss}$

typical numbers: $n_m > 99\% \cdot n_{sync}$ $s < 0.01$ $f_{rot} < 0.6 \cdot \text{Hz}$

The rotor speed is slightly less than the synchronous speed, typically within 1%. The magnetic field cuts the rotor conductors just fast enough to induce just enough rotor voltage and current to produce just enough torque to overcome friction. There is no additional torque to turn any load with the motor shaft.

C The Full-load Condition $P_{out} = \text{Rated power of motor (often hp)}$ $\tau_{shaft} = \frac{P_{rated}}{\omega_{rated}}$ $\tau_{ind} = \tau_{shaft} + \tau_{mech_loss}$

typical numbers: $n_m > 95\% \cdot n_{sync}$ $s < 0.05$ $f_{rot} < 3 \cdot \text{Hz}$

The rotor spins at the rated speed of the motor, typically still within 5% of the synchronous speed. The magnetic field cuts the rotor conductors fast enough to induce enough rotor voltage and current to deliver the full, rated power to a load *and* overcome friction and windage. Since these ratings are usually shown on the "nameplate" attached to the motor, this is also called "nameplate operation". It is rare that the load will be just right to utilize the motor at its rated power, but we will often use the rated, or nameplate, numbers as a known operation point to make other calculations. Figure 7-37 in your textbook shows a motor nameplate.

B to C Normal Operation $P_{out} = \tau_{shaft} \cdot \omega_m$

The motor is working within its ratings. Its output power is determined by the mechanical load.

A to D The Linear Region

The curve is almost a straight line in this region. If you know one or two points of operation, you can use methods of proportionality to find other points.

E Pullout Torque

If you load down the motor too much, it will eventually stall. This stall will happen suddenly when the shaft torque reaches the pullout torque.

F Locked Rotor or Stall Condition $n_m = 0$ $s = 1$ $f_{rot} < 60 \cdot \text{Hz}$ $\tau_{ind} = \tau_{start}$ $P_{out} = 0$

This is also the starting point of the motor when first turned on, but then it's a transitory condition. The starting current can be very high and, in large motors, may require us to use special starting methods.

E to F Unstable Region

The motor transitions through this region very quickly. Either accelerating when starting or decelerating when stalling. When starting, most of the power converted from electrical to mechanical (P_{conv}) goes to accelerating the mass of the rotor and whatever is attached to it.

A to F The shape of this curve is dictated by the internal electrical workings of the motor and the transformer-like interaction of the stator with the rotor. It is particularly dependent on the resistance and reactance of the rotor. We'll explore this next with the electrical model of the motor.

Recall the non-ideal model of a transformer

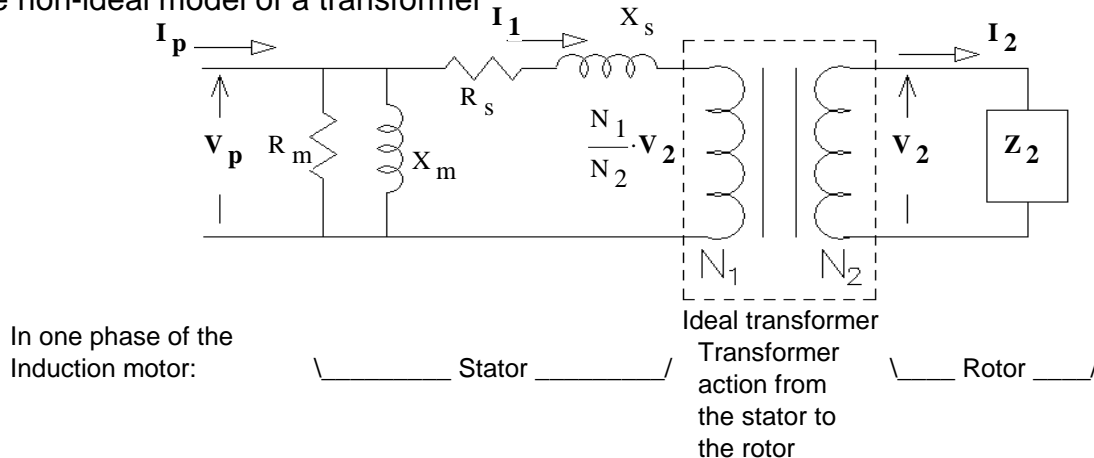

Based on the non-ideal model of a transformer with a number of modifications.

1. X_m and R_m are moved to the right of R_s and X_s because the air gap makes X_m a much smaller value and X_s much larger. Most are renamed.
2. The rotor resistance and reactance are moved to the primary side as R_2 and X_2 .
3. The resistance is shown as R_2/s because the voltage on the rotor depends on the slip but it's easier to think of the resistor as inversely dependent on slip.
4. The reactance would also be inversely dependent on slip, except the rotor reactance itself depends on the electrical frequency on the rotor like: $X_{rot} = \omega_{rot} \cdot L_{rot} = s \cdot \omega_{sync} \cdot L_{rot}$. The two effects cancel each other out.

Of particular interest is the power used by R_2/s because that's the power transferred from the stator to the rotor. It represents both the power needed to turn the rotor and power lost to I^2R losses in the rotor wires.

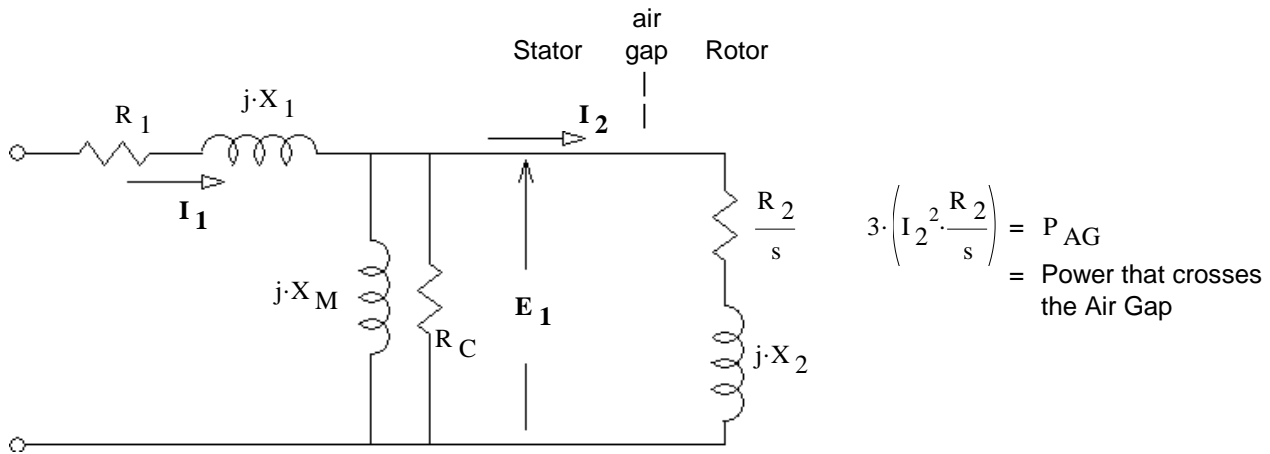

$$3 \cdot \left(I_2^2 \cdot \frac{R_2}{s} \right) = P_{AG}$$

= Power that crosses the Air Gap

= Stator Copper Losses

$$3 \cdot (I_1^2 \cdot R_1) = P_{SCL}$$

$$3 \cdot (I_2^2 \cdot R_2) = P_{RCL}$$

= Rotor Copper Losses

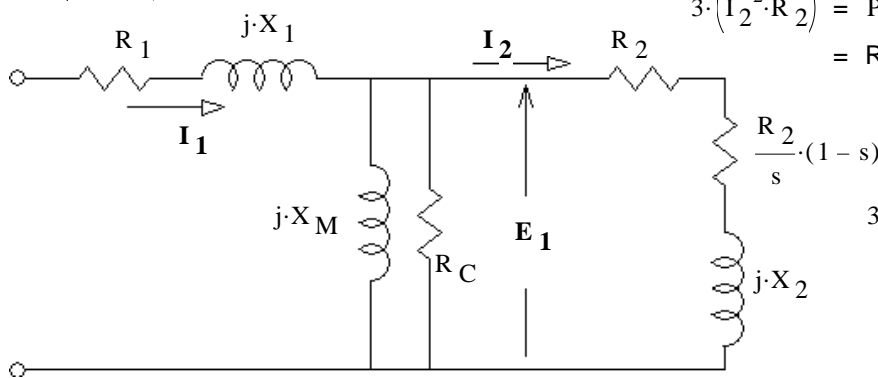

$$3 \cdot \left[I_2^2 \cdot \frac{R_2}{s} \cdot (1-s) \right] = P_{conv}$$

= $(1-s) \cdot P_{AG}$
= power converted to mechanical

$$3 \cdot \frac{E_1^2}{R_C} = P_{core}$$

= core loss

$$P_{out} = P_{conv} - P_{mech} - P_{misc}$$

mechanical losses

induced torque = $\tau_{ind} = \frac{P_{conv}}{\omega_m}$ OR: $\tau_{ind} = \frac{P_{AG}}{\omega_{sync}}$ (N·m)

load torque = $\tau_{load} = \frac{P_{out}}{\omega_m}$

Starting Current (Locked rotor)

$$Z_{eq} = R_1 + jX_1 + \frac{1}{\frac{1}{jX_M} + \frac{1}{R_C} + \frac{1}{jX_2 + R_2}}$$

Starting current: $I_{LR} = \frac{V_\phi}{Z_{eq}}$

Power Flow

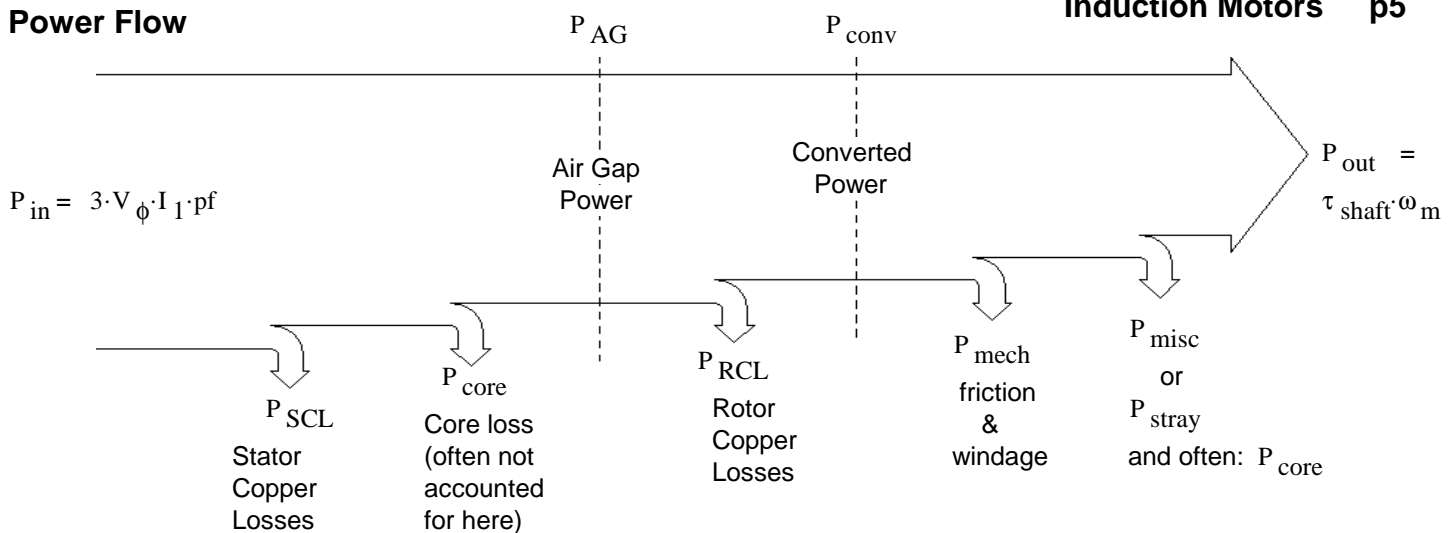

Typical torque-speed and power-speed curves for a 4-pole Induction motor

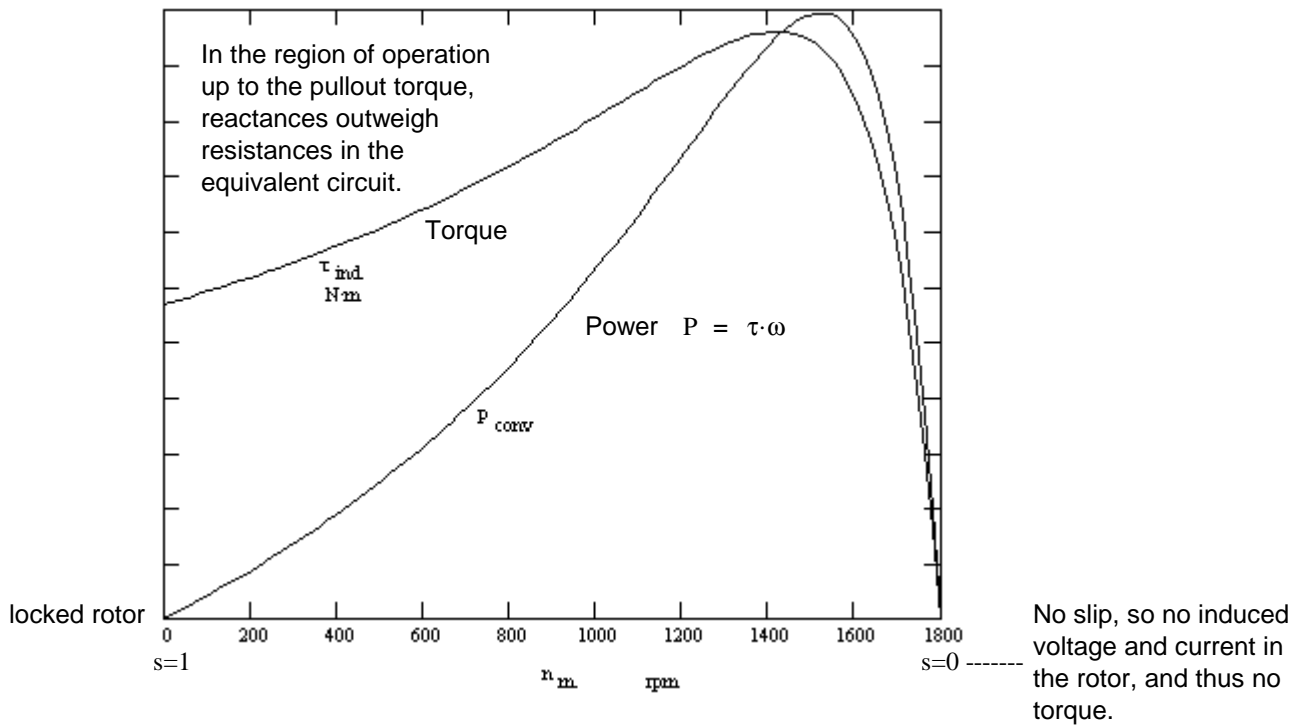

R_2 Affects Curve Shapes

These curves are greatly affected by the rotor resistance (R_2 in our model). See Fig 7-20 in the textbook.

- | | | |
|-------------|---|------|
| Low R_2 : | Higher efficiency at normal running | good |
| | Higher available power | good |
| | Better speed regulation at normal running | good |
| | Lower startup torque | bad |
| | Higher startup current | bad |

- | | | |
|--------------|---------------------------------------|------|
| High R_2 : | Lower efficiency at normal running | bad |
| | Less available power | bad |
| | More speed variance at normal running | bad |
| | Higher startup torque | good |
| | Lower startup current | good |

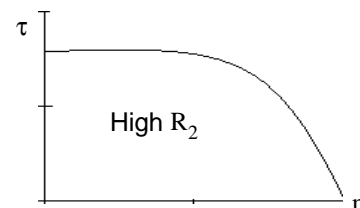
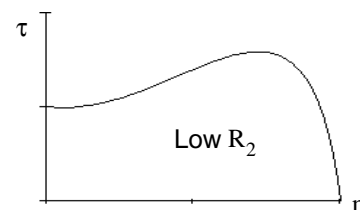

Torque-Speed Characteristics derived from the Model

Remove the resistor that changes with s and create a Thevenin equivalent of the rest of the model.
 Best illustrated with actual numbers

$V_\phi := \frac{208 \cdot V}{\sqrt{3}}$ $R_1 := 0.4 \cdot \Omega$ $R_C := 30 \cdot \Omega$ $R_2 := 0.2 \cdot \Omega$ $N_{poles} := 4$ $n_{sync} := \frac{7200 \cdot rpm}{N_{poles}}$
 $X_1 := 0.3 \cdot \Omega$ $X_M := 16 \cdot \Omega$ $X_2 := 0.4 \cdot \Omega$ $\omega_{sync} := \frac{240 \cdot \pi \cdot rad}{N_{poles} \cdot sec}$

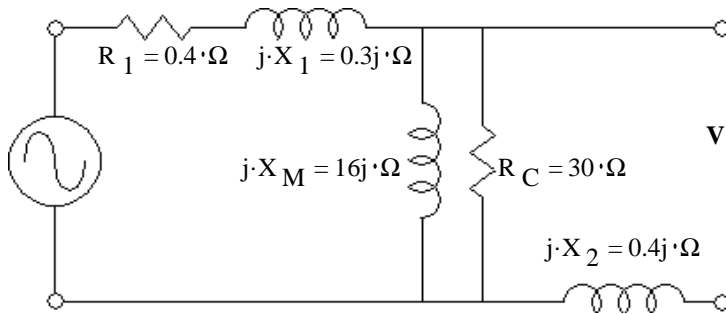

$$V_{Th} := V_\phi \cdot \frac{\left(\frac{1}{j \cdot X_M} + \frac{1}{R_C} \right)}{R_1 + j \cdot X_1 + \left(\frac{1}{j \cdot X_M} + \frac{1}{R_C} \right)}$$

$$V_{Th} = 116.331 + 1.691j \cdot V$$

$$V_{Th} := |V_{Th}| \quad V_{Th} = 116.343 \cdot V$$

$$\arg(V_{Th}) = 0.833 \cdot deg$$

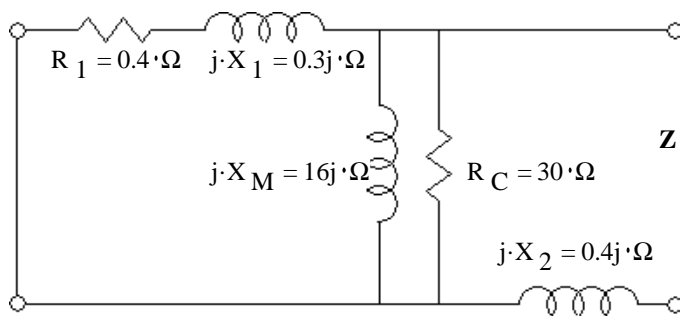

$$Z_{Th} := \frac{1}{\frac{1}{R_1 + j \cdot X_1} + \frac{1}{j \cdot X_M} + \frac{1}{R_C}} + j \cdot X_2$$

$$Z_{Th} = 0.383 + 0.696j \cdot \Omega$$

$$|Z_{Th}| = 0.7948 \cdot \Omega \quad \arg(Z_{Th}) = 61.169 \cdot deg$$

$$R_{Th} := \text{Re}(Z_{Th}) \quad R_{Th} = 0.383 \cdot \Omega$$

Maximum Induced Torque τ_{max}

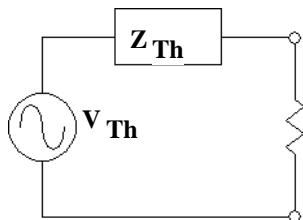

Maximum P_{AG} occurs at the s that makes $\frac{R_2}{s} = |Z_{Th}|$

and since: $\tau_{ind} = \frac{P_{AG}}{\omega_{sync}}$ that's also the s for maximum torque: $s_{max} = \frac{R_2}{|Z_{Th}|} = 0.252$

$$\tau_{max} = \frac{3 \cdot I^2 \cdot \left(\frac{R_2}{s_{max}} \right)}{\omega_{sync}} = \frac{3}{\omega_{sync}} \cdot \left[\frac{V_{Th}}{|Z_{Th} + \frac{R_2}{s_{max}}|} \right]^2 \cdot \left(\frac{R_2}{s_{max}} \right) = \frac{3}{\omega_{sync}} \cdot \left(\frac{V_{Th}}{|Z_{Th} + |Z_{Th}||} \right)^2 \cdot |Z_{Th}|$$

After some messy algebra: $\tau_{max} = \frac{3}{\omega_{sync}} \cdot \frac{V_{Th}^2}{2 \cdot (R_{Th} + |Z_{Th}|)} = 91.437 \cdot N \cdot m$

Starting Torque ($s = 1$)

$$\frac{3 \cdot I^2 \cdot R_2}{\omega_{sync}} = \frac{3}{\omega_{sync}} \cdot \left(\frac{V_{Th}}{|Z_{Th} + R_2|} \right)^2 \cdot R_2 = 52.228 \cdot N \cdot m$$

Maximum Power Converted to Mechanical P_{conv}

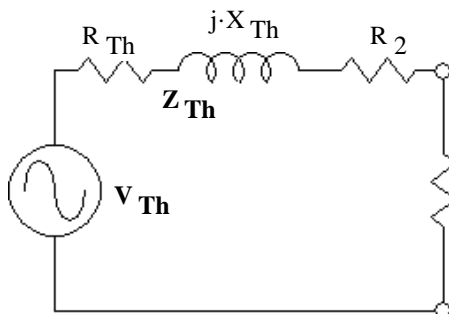

Maximum P_{conv} occurs at the s that makes $\frac{R_2}{s} \cdot (1-s) = |Z_{Th} + R_2|$

$$s_{maxP} = \frac{R_2}{|Z_{Th} + R_2| + R_2} = 0.1805$$

After similar messy algebra... $P_{conv,max} = 3 \cdot \frac{V_{Th}^2}{2 \cdot (R_{Th} + R_2 + |Z_{Th} + R_2|)} = 13.613 \cdot kW$

Now to get plots, let s change over a range $i := 0..1100$

$s_i := \frac{i}{500} - .995$ Notice it's not allowed to be 0

$s_{\max\tau} := \frac{R_2}{|Z_{Th}|}$ $n_{\max\tau} := (1 - s_{\max\tau}) \cdot n_{\text{sync}}$

$\tau_{\max} := \frac{3}{\omega_{\text{sync}}} \cdot \frac{V_{Th}^2}{2 \cdot (R_{Th} + |Z_{Th}|)}$

$s_{\max P} := \frac{R_2}{|Z_{Th} + R_2| + R_2}$ $n_{\max P} := (1 - s_{\max P}) \cdot n_{\text{sync}}$

$P_{\text{conv.max}} := 3 \cdot \frac{V_{Th}^2}{2 \cdot (R_{Th} + R_2 + |Z_{Th} + R_2|)}$

$n_{m_i} := (1 - s_i) \cdot n_{\text{sync}}$ $I_{2_i} := \frac{V_{Th}}{Z_{Th} + \frac{R_2}{s_i}}$ $P_{AG_i} := 3 \cdot \left[\left(|I_{2_i}| \right)^2 \cdot \frac{R_2}{s_i} \right]$ $\tau_{\text{ind}_i} := \frac{P_{AG_i}}{\omega_{\text{sync}}}$ $P_{\text{conv}_i} := (1 - s_i) \cdot P_{AG_i}$

Torque-speed curve

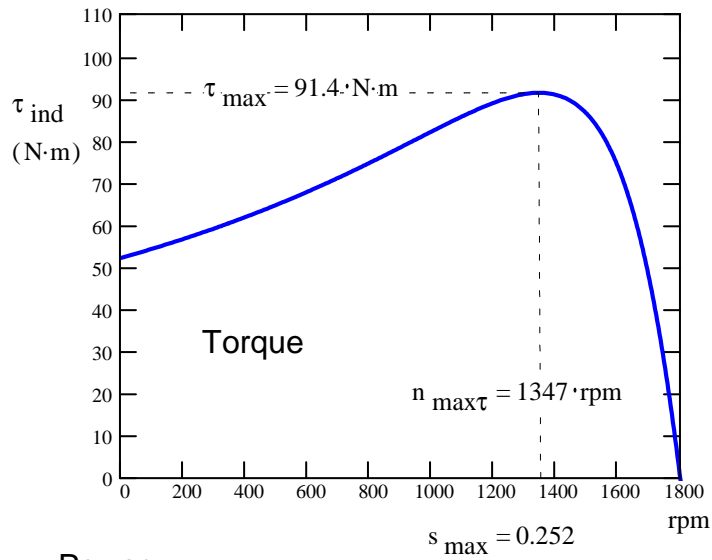

Power-speed curve

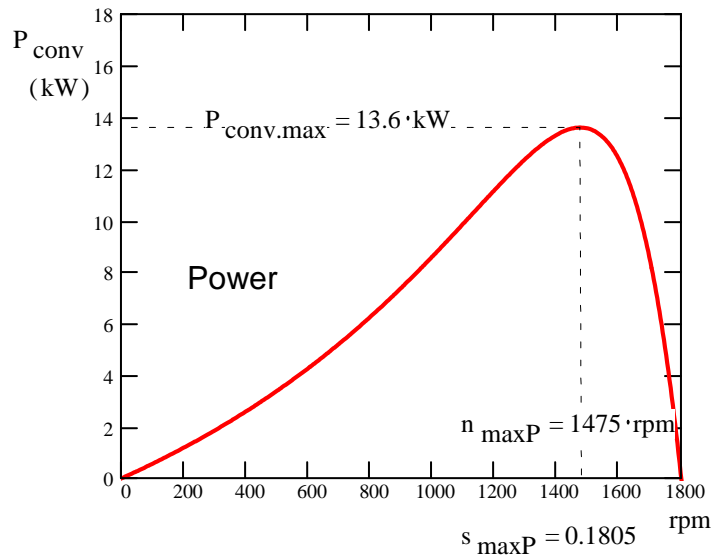

Power

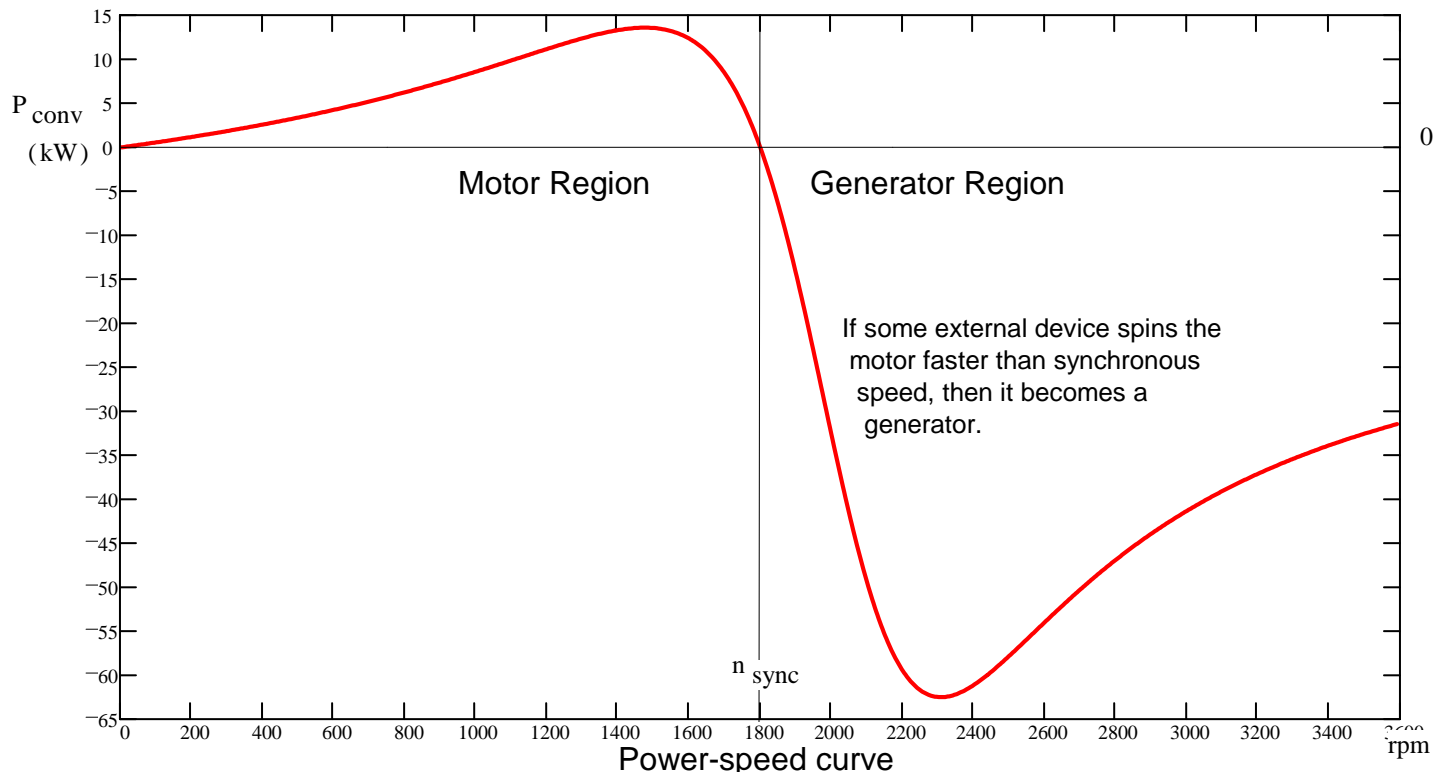

Power-speed curve

Induction Motors p8

By manipulating the design of the rotor cage, you can mix some of the benefits of both small and large R_2 values.

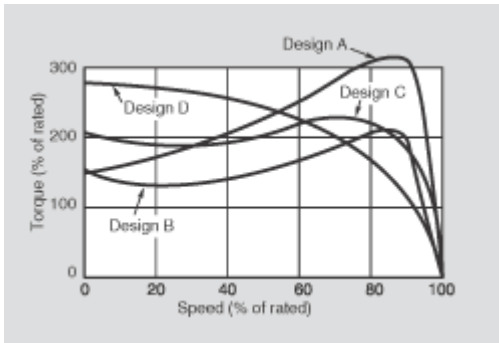

NEMA Designs, A, B, C, D

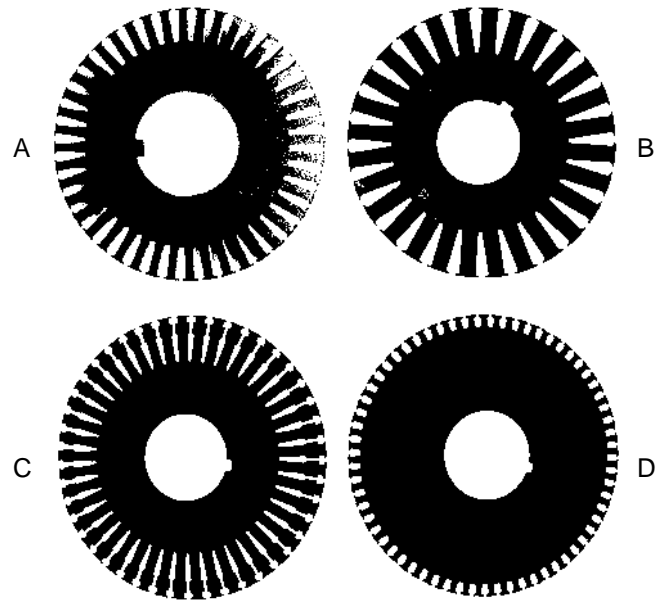

Rotor cross-sections

For more information about these different designs and how this works, see section 7.6 in your textbook.

Wound-Rotor See Figures 7-4 and 7-5 in your textbook

The squirrel-cage winding allows no control over the ever-important R_2 once the motor has been constructed. Another way to build an induction motor is to replace the few thick conductors of the squirrel-cage with many repeated thinner conductors wound on the rotor. Then you could allow that smaller current to flow through some slip rings to additional resistance outside of the motor. This is the wound-rotor induction motor. Added resistance would reduce the starting current and increase the starting torque-- both improvements. Shorting the added resistance once the motor has reached operating speed would improve the motor's efficiency, power, and speed regulation. You could achieve similar results right on the rotor with one or more centrifugal switches.

Starting Induction Motors

Starting an induction motor from a stopped condition can require enormous surge currents. Much of the fuss over R_2 comes from starting issues. All sorts of methods have been used to limit the starting current. Most involve starting at a lower voltage and then switching to a higher voltage once the motor is near its operating speed. The initial lower voltage can be achieved by adding resistance, using transformers or autotransformers, or using a Y connection at starting and a Δ connection at run. All involve switches like those shown in Figure 7-28 in your textbook. (Please note that the symbols we might take for capacitors are actually switch contacts.)

All these methods that require switches and relays are losing popularity now that Variable-Frequency Drives (VFDs) are becoming cheaper and more reliable. See the next section.

Speed Control of Induction Motors

There is really only one good method to control the speed of an induction motor-- the Variable-Frequency Drive (VFD). A VFD takes in AC power, rectifies it to make DC, and then creates a different frequency using power electronics. This effectively changes the n_{sync} .

At lower frequencies than the motor is rated for, the VFD must also decrease the voltage to avoid saturating the motor core.

At higher frequencies than the motor is rated for, the VFD doesn't increase the voltage to avoid damaging the motor insulation. Centrifugal forces can also damage the motor at higher than rated speed.

Figure 7-29c (p334) in your textbook shows a family of torque-speed curves for a 4-pole motor controlled by a VFD. Also, watch the animation presented in class.

Variable-Frequency Drives are becoming so affordable and reliable that you will see more and more of them, even just to limit the starting current.

VFDs are so effective that induction motors are now routinely used in place of DC motors where speed control is essential. DC motors used to be the only practical choice for those applications.

Determining Circuit Model Parameters

Standard Circuit Model or one phase of an induction motor.

How do we find R_1 R_C R_2
 X_1 X_M X_2
 from measurements ??

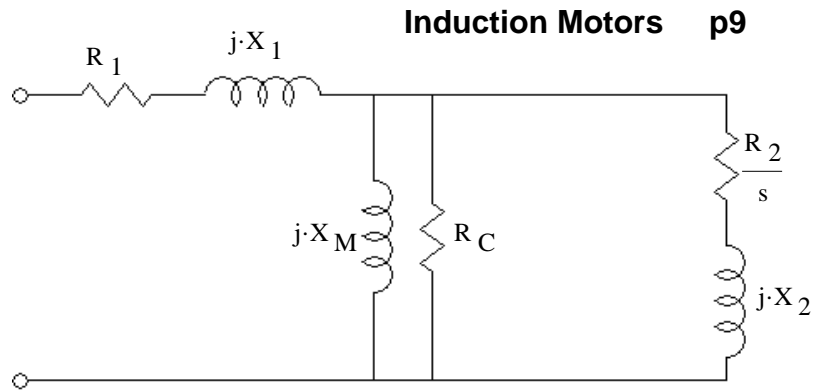

Turn to section 7.9 in your textbook. Follow along as we go through this section.

Refer to IEEE Standard 112 for more information if you ever have to make these measurements for real.

DC test to find R_1

Use DC voltage and current to find R_1 . With DC input, the model reduces to:

The book recommends making this measurement at rated current, so that the winding will be close to normal temperature. Be mindful of the connection that you have to the motor.

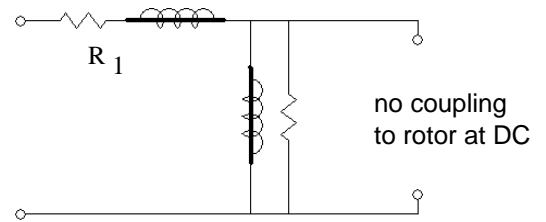

If it isn't a Y-connected motor with an available neutral connection, like this:

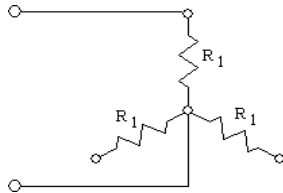

Then you may be measuring $2 \cdot R_1$

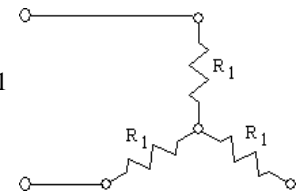

For actual Y-connected motor or Y-model of a Δ -connected motor.

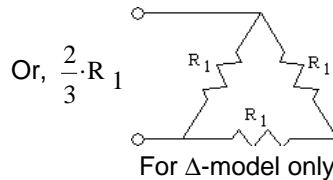

Note: All of the calculations made in section 7.9 assume a Y-connected motor (or a Y-model of a Δ -connected motor).

Measuring 3-phase Power with Two Wattmeters (Balanced)

With the wattmeters connected as shown in Figure 7-33:

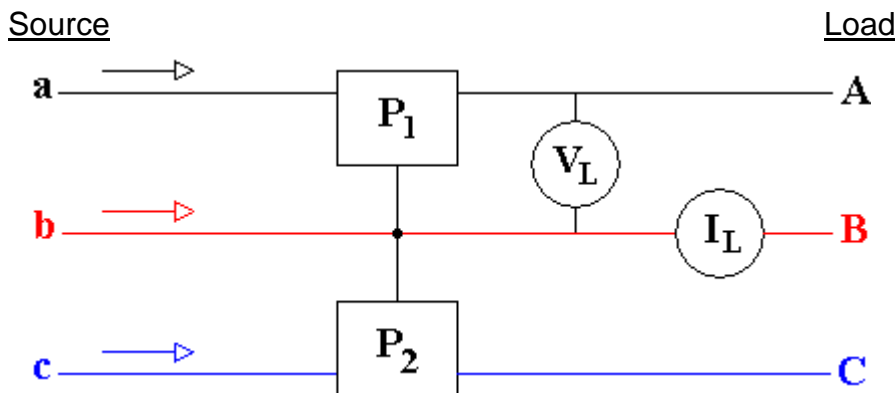

$$P_{3\phi} = P_1 + P_2 = \sqrt{3} \cdot V_L \cdot I_L \cdot \cos(\theta)$$

$$Q_{3\phi} = \sqrt{3} \cdot (P_2 - P_1) = \sqrt{3} \cdot V_L \cdot I_L \cdot \sin(\theta)$$

$$S_{3\phi} = \sqrt{P_{3\phi}^2 + Q_{3\phi}^2} = \sqrt{3} \cdot V_L \cdot I_L$$

No-Load Test Shaft is free-running--not coupled to any load.

Run motor at rated voltage,
Measure: $P_{3\phi}$, I_{ϕ} , and V_{ϕ}

After several steps of simplification, see Fig. 7-33

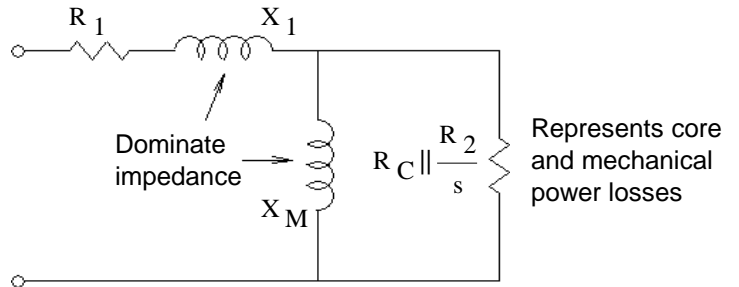

$$P_{3\phi} = P_{SCL} + P_{core} + P_{FW} + P_{misc}$$

$$P_{SCL} = 3 \cdot I_{\phi}^2 \cdot R_1$$

Find $P_{rot} = P_{core} + P_{FW} + P_{misc}$
 P_{FW} = Power lost to friction and windage

And approximate $X_1 + X_M \approx \frac{V_{\phi}}{I_{\phi}}$

Locked-Rotor Test

Shaft is not allowed to turn

This test is often performed at 10 or 15 Hz (f_{test}) rather than the normal 60 Hz (f_{rated}).

The motor is subjected to a very short test at rated current,

Measure: $P_{3\phi}$, I_{ϕ} , and V_{ϕ} to find Z_{LR}

After simplification, see Fig. 7-34

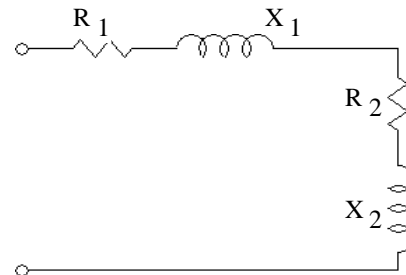

Determine $Z_{LR} = (R_1 + R_2) + X'_{LR} \cdot j$ which yields R_2 since R_1 is known from the DC test.

$$(X_1 + X_2) \approx \frac{f_{rated}}{f_{test}} \cdot X'_{LR}$$

separate into X_1 and X_2 using the table below (or Figure 7-35 in text)

Rotor Design	Split of $X_1 + X_2$	
	X_1	X_2
Wound rotor	$0.5 \cdot (X_1 + X_2)$	$0.5 \cdot (X_1 + X_2)$
Design A	$0.5 \cdot (X_1 + X_2)$	$0.5 \cdot (X_1 + X_2)$
Design B	$0.4 \cdot (X_1 + X_2)$	$0.6 \cdot (X_1 + X_2)$
Design C	$0.3 \cdot (X_1 + X_2)$	$0.7 \cdot (X_1 + X_2)$
Design D	$0.5 \cdot (X_1 + X_2)$	$0.5 \cdot (X_1 + X_2)$

Then use X_1 and the value of $X_1 + X_M$ from the no-load test to find X_M .

ECE 3600 Induction Motor Examples

A. Stolp
11/7/11
rev 11/2/18,
10/12/22

Ex. 1 A 480-V, six-pole, 60-Hz, Δ -connected, 3-phase induction motor is rated at 60 hp.
Its equivalent circuit components are

$R_1 := 0.480 \cdot \Omega$	$R_2 := 0.6 \cdot \Omega$	$R_C := \infty \cdot \Omega$
$X_1 := 0.50 \cdot \Omega$	$X_2 := 0.60 \cdot \Omega$	$X_M := 30 \cdot \Omega$
$P_{\text{mech}} := 600 \cdot \text{W}$	$P_{\text{misc}} := 150 \cdot \text{W}$	$P_{\text{core}} := 200 \cdot \text{W}$
$N_{\text{poles}} := 6$	$V_\phi := 480 \cdot \text{V}$	$V_\phi = 480 \cdot \text{V}$

For a slip of 0.04 $s := 4\%$, find:

a) The line current (magnitude)

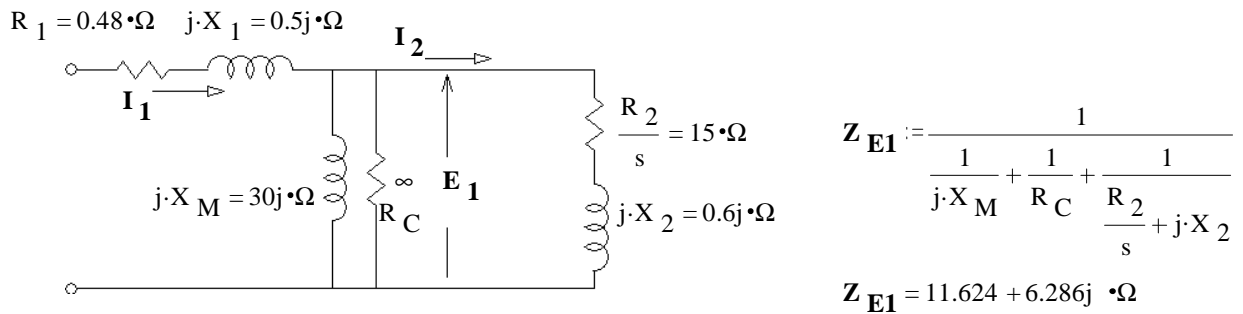

$$Z_{\text{eq}} := R_1 + j \cdot X_1 + Z_{E1} \quad Z_{\text{eq}} = 12.104 + 6.786j \cdot \Omega$$

$$I_1 := \frac{V_\phi}{Z_{\text{eq}}} \quad I_1 = 30.171 - 16.916j \cdot \text{A}$$

$$|I_1| = 34.59 \cdot \text{A} \quad \arg(I_1) = -29.278 \cdot \text{deg} \quad \Delta\text{-connected} \quad I_L = |I_1| \cdot \sqrt{3} = 59.91 \cdot \text{A}$$

b) The stator copper losses $P_{\text{SCL}} := 3 \cdot [(|I_1|)^2 \cdot R_1] \quad P_{\text{SCL}} = 1.723 \cdot \text{kW}$

c) The air-gap power P_{AG}

$$E_1 := I_1 \cdot Z_{E1} \quad E_1 = 457.06 - 6.966j \cdot \text{V}$$

$$I_2 := \frac{E_1}{j \cdot X_2 + \frac{R_2}{s}} \quad P_{\text{AG}} := 3 \cdot [(|I_2|)^2 \cdot \frac{R_2}{s}] \quad P_{\text{AG}} = 41.72 \cdot \text{kW}$$

$$P_{\text{AG}} = 55.95 \cdot \text{hp}$$

d) The power converted from electrical to mechanical form

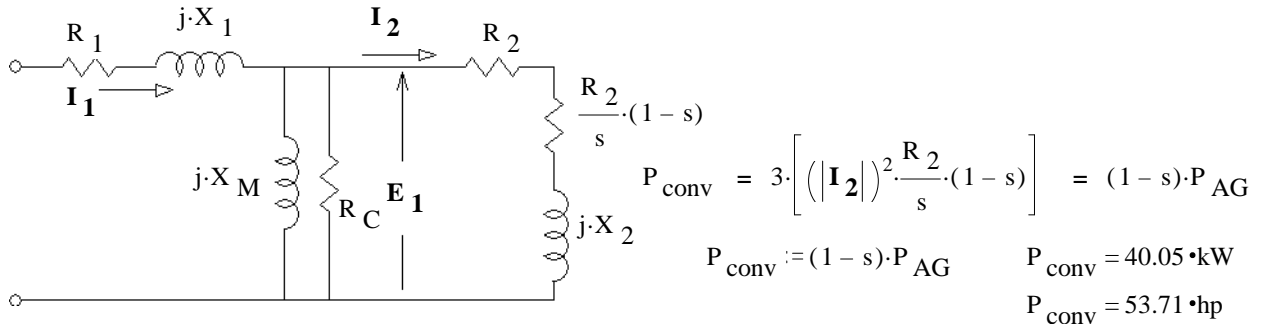

e) The motor speed in revolutions per minute and radians per second

$$n_{\text{sync}} := \frac{7200 \cdot \text{rpm}}{N_{\text{poles}}} \quad n_{\text{sync}} = 1200 \cdot \text{rpm} \quad \omega_{\text{sync}} := n_{\text{sync}} \cdot \left(2 \cdot \pi \cdot \frac{\text{rad}}{\text{rev}} \right) \cdot \left(\frac{\text{min}}{60 \cdot \text{sec}} \right) \quad \omega_{\text{sync}} = 125.7 \cdot \frac{\text{rad}}{\text{sec}}$$

$$n_m := (1-s) \cdot n_{\text{sync}} \quad n_m = 1152 \cdot \text{rpm} \quad \omega_m := (1-s) \cdot \omega_{\text{sync}} \quad \omega_m = 120.6 \cdot \frac{\text{rad}}{\text{sec}}$$

ECE 3600 Induction Motor Examples p2

f) The induced torque $\tau_{ind} := \frac{P_{conv}}{\omega_m}$ OR: $\tau_{ind} := \frac{P_{AG}}{\omega_{sync}}$ (easier) $\tau_{ind} = 332 \cdot \text{N}\cdot\text{m}$

g) The load torque τ_{load}

Use P_{core} here. Lump it in with the mechanical losses, P_{misc} and P_{mech} . Read the last 2 paragraphs on p.302.

$$P_{out} := P_{conv} - P_{core} - P_{mech} - P_{misc} \quad P_{out} = 39.105 \cdot \text{kW}$$

$$\tau_{load} := \frac{P_{out}}{\omega_m} \quad \tau_{load} = 324.152 \cdot \text{N}\cdot\text{m}$$

h) The overall machine efficiency $\eta := \frac{P_{out}}{3 \cdot V_{\phi} \cdot \text{Re}(\mathbf{I}_1)}$ $\eta = 90.006\%$

Ex. 2 For the motor in Example 1,

a) what is the slip at the pullout torque?

Create a Thevenin equivalent of the model with $(R_2/s + X_2)$ as the load.

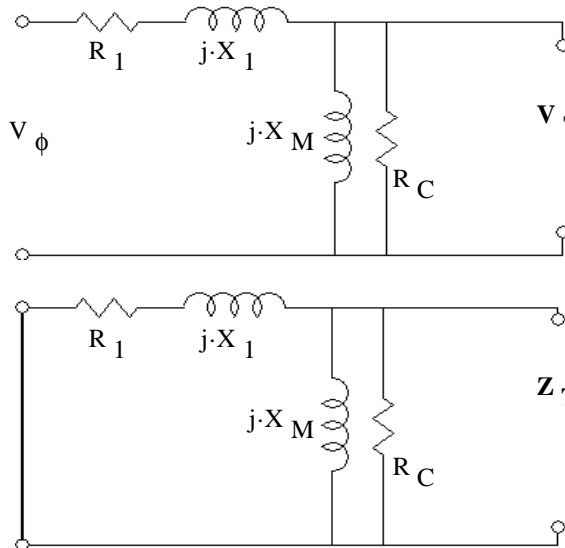

$$\mathbf{V}_{TH} := V_{\phi} \cdot \frac{j \cdot X_M}{R_1 + j \cdot X_1 + j \cdot X_M}$$

$$\mathbf{V}_{TH} = 472.014 + 7.428j \cdot \text{V}$$

$$|\mathbf{V}_{TH}| = 472.073 \cdot \text{V}$$

$$\mathbf{Z}_{TH} := \frac{1}{\frac{1}{R_1 + j \cdot X_1} + \frac{1}{j \cdot X_M}}$$

$$\mathbf{Z}_{TH} = 0.464 + 0.499j \cdot \Omega$$

$$|\mathbf{Z}_{TH}| = 0.6817 \cdot \Omega \quad \arg(\mathbf{Z}_{TH}) = 47.07 \cdot \text{deg}$$

At max P_{AG} $\frac{R_2}{s} = |\mathbf{Z}_{TH} + j \cdot X_2| = 1.193 \cdot \Omega$ $s := \frac{R_2}{|\mathbf{Z}_{TH} + j \cdot X_2|}$ $s = 50.287\%$

b) What is the pullout torque of this motor?

$$n_m := (1 - s) \cdot n_{sync} \quad n_m = 596.553 \cdot \text{rpm} \quad \omega_m := n_m \cdot \left(2 \cdot \pi \cdot \frac{\text{rad}}{\text{rev}}\right) \cdot \left(\frac{\text{min}}{60 \cdot \text{sec}}\right) \quad \omega_m = 62.471 \cdot \frac{\text{rad}}{\text{sec}}$$

$$\mathbf{I}_2 := \frac{\mathbf{V}_{TH}}{\mathbf{Z}_{TH} + j \cdot X_2 + \frac{R_2}{s}} \quad P_{AG} := 3 \cdot \left[(|\mathbf{I}_2|)^2 \cdot \frac{R_2}{s} \right] \quad P_{AG} = 201.686 \cdot \text{kW}$$

$$P_{conv} := (1 - s) \cdot P_{AG} \quad P_{conv} = 100.264 \cdot \text{kW}$$

$$\tau_{max} := \frac{P_{conv}}{\omega_m} \quad \tau_{max} = 1605 \cdot \text{N}\cdot\text{m}$$

ECE 3600 Induction Motor Examples p3

Ex. 3 A 3-phase, Y-connected, induction motor has the following equivalent circuit components:

currently running at $n := 3500\text{-rpm}$
 current air-gap power $P_{AG} := 7.5\text{-kW}$

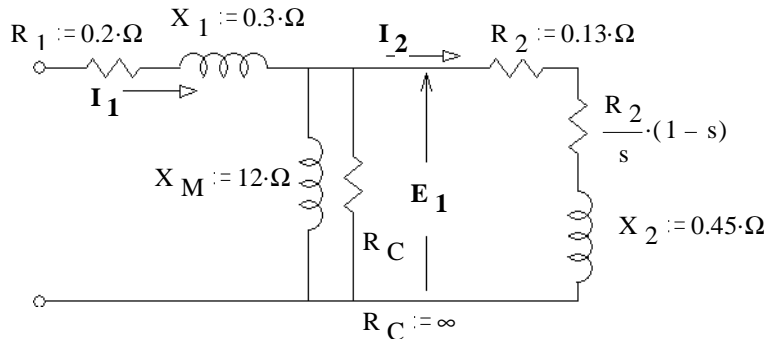

a) Find $|I_2|$

This has to be a 2-pole motor, so $n_{sync} := 3600\text{-rpm}$ and $s := \frac{3600 - 3500}{3600} = 2.778\%$

$$\frac{P_{AG}}{3} = I_2^2 \cdot \frac{R_2}{s} \quad I_2 := \sqrt{\frac{P_{AG} \cdot s}{3 \cdot R_2}} \quad I_2 = 23.113 \cdot A$$

b) Find the rotor copper losses $P_{RCL} := 3 \cdot I_2^2 \cdot R_2 \quad P_{RCL} = 208.333 \cdot W$

c) The output shaft torque is $\tau_{load} := 19 \cdot N \cdot m$

Find the output power $P_{out} := \tau_{load} \cdot n \cdot \frac{2 \cdot \pi \cdot \text{rad}}{\text{rev}} \cdot \frac{\text{min}}{60 \cdot \text{sec}} \quad P_{out} = 6.964 \cdot kW$

d) Find the mechanical power losses (all lumped together).

$$P_{mech} := P_{AG} - P_{RCL} - P_{out} \quad P_{mech} = 327.803 \cdot W$$

e) Find the line current. Note: Don't try any shortcuts here. You need to do your math with full complex numbers.

$|I_L| = ?$ I advise you to assume the phase angle of I_2 is 0° .

$$E_1 := I_2 \cdot \left(\frac{R_2}{s} + j \cdot X_2 \right) \quad E_1 = 108.167 + 10.401j \cdot V$$

$$I_L := I_2 + \frac{E_1}{j \cdot X_M} \quad |I_L| = 25.617 \cdot A$$

$$V_\phi := E_1 + I_L \cdot (R_1 + j \cdot X_1) \quad |V_\phi| = 116.7 \cdot V$$

NOT asked for

f) The stator copper losses $P_{SCL} := 3 \cdot (|I_L|)^2 \cdot R_1 \quad P_{SCL} = 393.75 \cdot W$

g) The overall machine efficiency $\eta = \frac{P_{out}}{P_{SCL} + P_{AG}} = 88.22\%$

Ex. 4

A 480-V, four-pole, 60-Hz, Y-connected, induction motor is rated at 20 hp. Its equivalent circuit components are:

$$\begin{array}{lll} N_{\text{poles}} := 4 & R_1 := 1 \cdot \Omega & R_2 := 0.6 \cdot \Omega \\ & X_1 := 2 \cdot \Omega & X_2 := 2 \cdot \Omega & X_M := 75 \cdot \Omega \\ & P_{\text{mech}} := 300 \cdot \text{W} & P_{\text{misc}} := 0 \cdot \text{W} & P_{\text{core}} := 0 \cdot \text{W} \end{array}$$

For a slip of 0.06, the following values have been calculated for you: $s := 0.06$

$$\mathbf{E}_1 := (234.208 - 32.217 \cdot j) \cdot \text{V} \quad |\mathbf{E}_1| = 236.413 \cdot \text{V} \quad \text{The line current magnitude: } I_L := 24 \cdot \text{A}$$

Find the following:

a) The stator copper losses

$$P_{\text{SCL}} := 3 \cdot (I_L^2 \cdot R_1) \quad P_{\text{SCL}} = 1.728 \cdot \text{kW}$$

b) The air-gap P_{AG}

$$I_2 := \frac{|\mathbf{E}_1|}{\sqrt{X_2^2 + \left(\frac{R_2}{s}\right)^2}} \quad P_{\text{AG}} := 3 \cdot \left(I_2^2 \cdot \frac{R_2}{s}\right) \quad P_{\text{AG}} = 16.122 \cdot \text{kW}$$

c) The power converted from electrical to mechanical form

$$P_{\text{conv}} := (1 - s) \cdot P_{\text{AG}} \quad P_{\text{conv}} = 15.155 \cdot \text{kW}$$

d) The motor speed in revolutions per minute and radians per second

$$\begin{array}{lll} n_{\text{sync}} := \frac{7200 \cdot \text{rpm}}{N_{\text{poles}}} & n_{\text{sync}} = 1800 \cdot \text{rpm} & \omega_{\text{sync}} := n_{\text{sync}} \cdot \left(2 \cdot \pi \cdot \frac{\text{rad}}{\text{rev}}\right) \cdot \left(\frac{\text{min}}{60 \cdot \text{sec}}\right) \\ & & \omega_{\text{sync}} = 188.496 \cdot \frac{\text{rad}}{\text{sec}} \quad \text{OR} \quad \frac{377}{2} = 188.5 \cdot \frac{\text{rad}}{\text{sec}} \end{array}$$

$$\begin{array}{lll} n_m := (1 - s) \cdot n_{\text{sync}} & n_m = 1692 \cdot \text{rpm} & \omega_m := n_m \cdot \left(2 \cdot \pi \cdot \frac{\text{rad}}{\text{rev}}\right) \cdot \left(\frac{\text{min}}{60 \cdot \text{sec}}\right) \\ & & \omega_m = 177.186 \cdot \frac{\text{rad}}{\text{sec}} \end{array}$$

e) The induced torque τ_{ind}

$$\tau_{\text{ind}} := \frac{P_{\text{conv}}}{\omega_m} \quad \text{OR:} \quad \tau_{\text{ind}} := \frac{P_{\text{AG}}}{\omega_{\text{sync}}} \quad \tau_{\text{ind}} = 85.533 \cdot \text{N} \cdot \text{m}$$

f) The load torque τ_{load}

$$\begin{array}{lll} P_{\text{out}} := P_{\text{conv}} - P_{\text{core}} - P_{\text{mech}} - P_{\text{misc}} & & P_{\text{out}} = 14.855 \cdot \text{kW} \\ & & P_{\text{out}} = 19.921 \cdot \text{hp} \\ & \tau_{\text{load}} := \frac{P_{\text{out}}}{\omega_m} & \tau_{\text{load}} = 83.839 \cdot \text{N} \cdot \text{m} \end{array}$$

g) The overall machine efficiency $\eta = \frac{P_{\text{out}}}{P_{\text{SCL}} + P_{\text{AG}}} = 83.22 \cdot \%$

h) Is this motor running close to it's rated output?

Yes, $P_{\text{out}} = 19.921 \cdot \text{hp}$ rating is 20 hp

Name _____ ECE 3600 homework Ind1

Answer the following questions in your textbook, starting on p.347.

7-1. What are slip speed and slip in an induction motor?

7-3. Why is it impossible for an induction motor to operate at synchronous speed?

7-4 Sketch and explain the shape of a typical induction motor torque-speed characteristic curve.

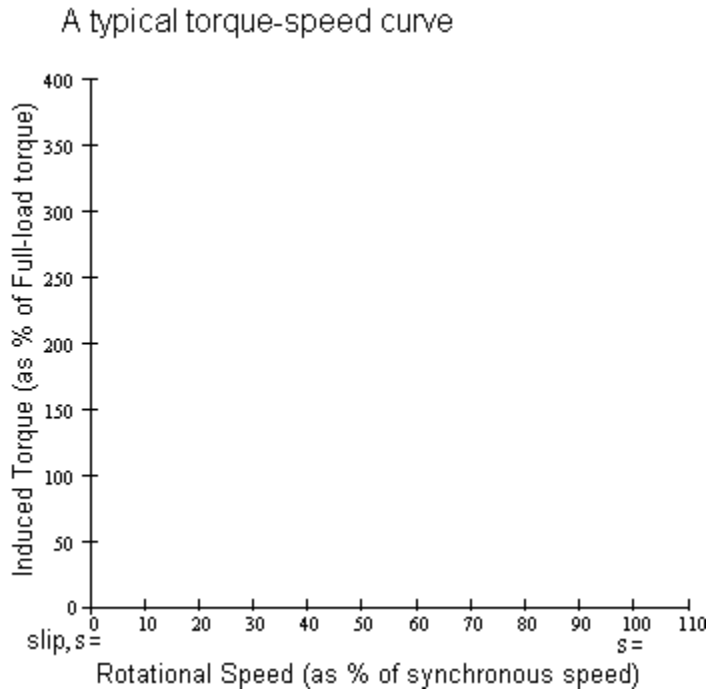

7-5. What equivalent circuit element has the most direct control over the speed at which the pullout torque occurs?

7-9. Why is the efficiency of an induction motor (wound rotor or squirrel cage) so poor at high slips?

7-16. Two 480-V, 100-hp induction motors are manufactured. One is designed for 50-Hz operation. and one is designed for 60-Hz operation, but they are otherwise similar. Which of these machines is larger?

7-17. An induction motor is running at the rated conditions. If the shaft load is now increased, how do the following quantities change?

- a. Mechanical speed _____
- b. Slip _____
- c. Rotor induced voltage _____
- d. Rotor current _____
- e. Rotor frequency _____
- f. Synchronous speed _____

Solve the following problems in your textbook, starting on p.348.

1. 7-3 A 480-V three-phase four-pole 60-Hz induction motor is running at a slip of 0.025. Find:

- a) The speed of the magnetic fields in revolutions per minute
- b) The speed of the rotor in revolutions per minute
- c) The slip speed of the rotor
- d) The rotor frequency in hertz

2. 7-4 A three-phase 60-Hz induction motor runs at 710 rpm at no load and at 670 rpm at full load.
- How many poles does this motor have?
 - What is the slip at rated load?
 - What is the speed at one-quarter of the rated shaft torque?
(You may assume the torque-speed curve is linear in this region).
 - What is the rotor's electrical frequency at one-quarter of the rated shaft torque?
3. 7-5 A 50-kW 440-V 50-Hz two-pole induction motor has a slip of 6 percent when operating at full-load conditions. At full-load conditions, the friction and windage losses are 520 W, and the core losses are 500 W. Find the following values for full-load conditions:
- The shaft speed n_m
 - The output power in watts
 - The load torque load τ_{load} in newton-meters
 - The induced torque τ_{ind} in newton-meters
 - The rotor frequency in hertz
4. A three-phase 60-Hz two-pole induction motor runs at a no-load speed of 3580 rpm and a full-load speed of 3440 rpm. Calculate the slip and the electrical frequency of the rotor at no-load and full-load conditions. What is the speed regulation of this motor [Equation (4-57)]?

Answers

- | | | | | |
|----------------|-------------|------------|------------|---------|
| 1. a) 1800·rpm | b) 1755·rpm | c) 45·rpm | d) 1.5·Hz | |
| 2. a) 10 | b) 6.94·% | c) 700·rpm | d) 1.67·Hz | |
| 3. a) 2820·rpm | b) 50·kW | c) 169·N·m | d) 173·N·m | e) 3·Hz |
| 4. 0.56·% | 0.33·Hz | 4.44·% | 2.67·Hz | 4.1·% |

Name _____ ECE 3600 homework Ind2

Solve the following problems in your textbook, starting on p.348.

1. 7-7. A 208-V. four-pole, 60-Hz, Y-connected, wound-rotor induction motor is rated at 15 hp.

Its equivalent circuit components are

$$N_{\text{poles}} := 4$$

$$R_1 := 0.220 \cdot \Omega$$

$$R_2 := 0.127 \cdot \Omega$$

$$X_1 := 0.430 \cdot \Omega$$

$$X_2 := 0.430 \cdot \Omega$$

$$X_M := 15 \cdot \Omega$$

$$P_{\text{mech}} := 300 \cdot \text{W}$$

$$P_{\text{misc}} := 0 \cdot \text{W}$$

$$P_{\text{core}} := 200 \cdot \text{W}$$

For a slip of 0.05, find

a) The line current To get the book answers (which are the answers that I gave you), Do not include P_{core} in your calculation of the line current. Assume there is no R_C in the equivalent circuit.

b) The stator copper losses

c) The air-gap P_{AG}

d) The power converted from electrical to mechanical form

e) The induced torque τ_{ind}

f) The load torque τ_{load}

Use P_{core} here. Lump it in with the mechanical losses, P_{misc} and P_{mech} . Read the last 2 paragraphs on p.302.

g) The overall machine efficiency

h) The motor speed in revolutions per minute and radians per second

2. 7-8. For the motor in Problem 7-7,

a) what is the slip at the pullout torque? Find V_{Th} and Z_{Th} as part of your solution, you will need them again in problem 3, which you may want to read before finding these by hand.

b) What is the pullout torque of this motor?

ECE 3600 homework Ind2 p3

3. 7-9 Use Matlab, a spreadsheet, or the program or method of your choice to:

- a) Calculate and plot the torque-speed characteristic of the motor in Problem 7-7.
- b) Calculate and plot the converted power versus speed curve of the motor in Problem 7-7.

Attach Plots as separate pages

4. 7-10. For the motor of Problem 7-7, how much additional resistance (referred to the stator circuit) would it be necessary to add to the rotor circuit to make the maximum torque occur at starting conditions (when the shaft is not moving)? Plot the torque-speed characteristic of this motor with the additional resistance inserted.

5. 7-11 (partial) If the motor in Problem 7-7 is to be operated on a 50-Hz power system, what must be done to its supply voltage? Why?

Answers

1. a) $42.3 \cdot A \angle -25.7 \cdot \text{deg}$ b) 1180·W c) 12.54·kW d) 11.92·kW e) 66.5·N·m f) 63.8·N·m

g) 83.2·% h) 1710·rpm $179 \cdot \frac{\text{rad}}{\text{sec}}$

2. a) 14.5·% b) 100·N·m

4. 0.749·Ω more

Plot looks like R_s plot on Fig 7-31, peaking at about 100Nm

5. Decrease applied voltage to 5/6th of value at 60Hz. Otherwise core will saturate.

3. a)

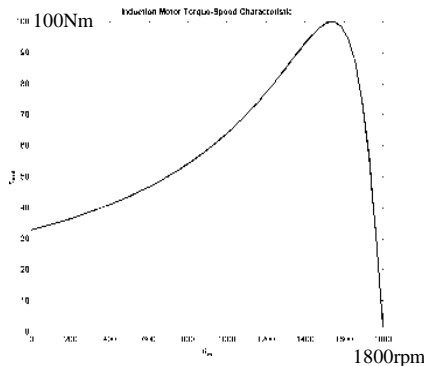

b)

