

Simplified Drawing of a Motor or Generator (Exploded view)

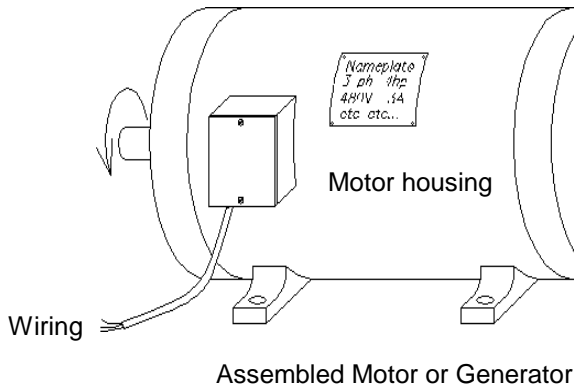
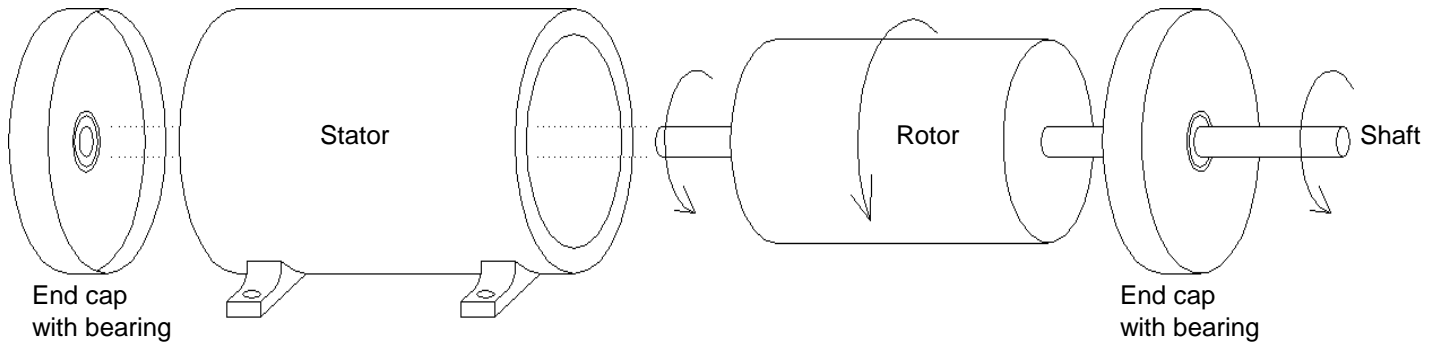

Torque  $T$  or  $\tau$ , N·m

Angular Velocity  $\omega$ ,  $\frac{\text{rad}}{\text{sec}}$  or  $n$ ,  $\frac{\text{rev}}{\text{min}}$  or rpm

Angular Acceleration  $\alpha$ ,  $\frac{\text{rad}}{\text{sec}^2}$

Mechanical Power  $P_{\text{shaft}}$  or  $P_{\text{out}}$  W or hp (horse power)

$= \tau \cdot \omega$

Generator: Torque as shown would come from some other rotating device, the *prime-mover* (not shown). The mechanical, shaft power would be into the generator.

Motor: Torque as shown would be caused by the motor overcoming a mechanical *load* resisting the motor's rotation (not shown). The mechanical, shaft power would be out of the motor. If the shaft were not coupled to some mechanical load the motor would spin freely (the no-load condition).

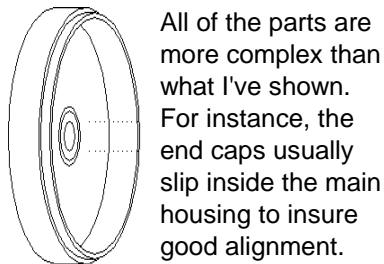

Many drawings of motors, especially those designed to show how the motor works, show the motor from one end and only show the most important parts.

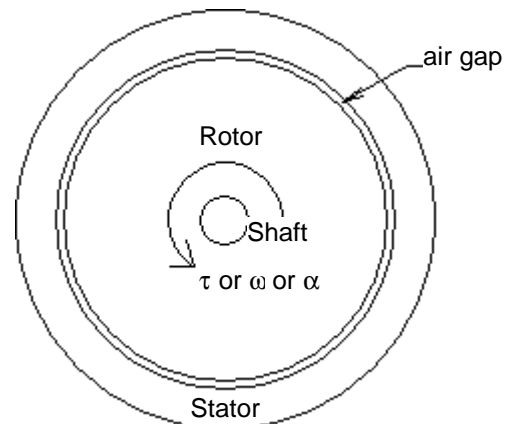

This is, of course, an electrical device, so it needs some wiring,

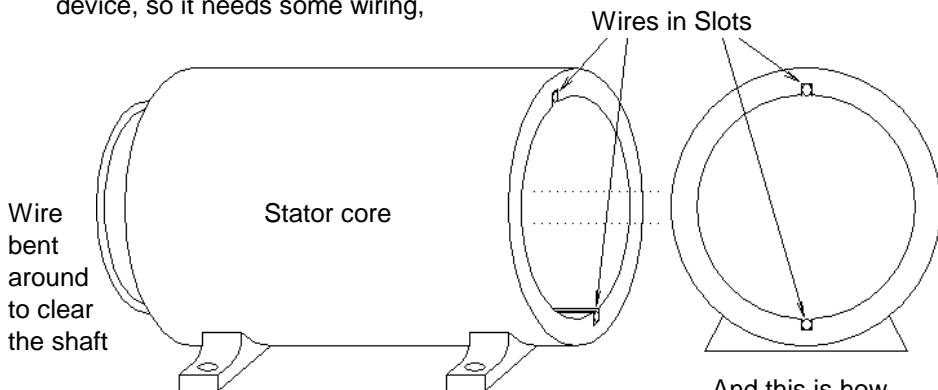

And this is how details will be shown

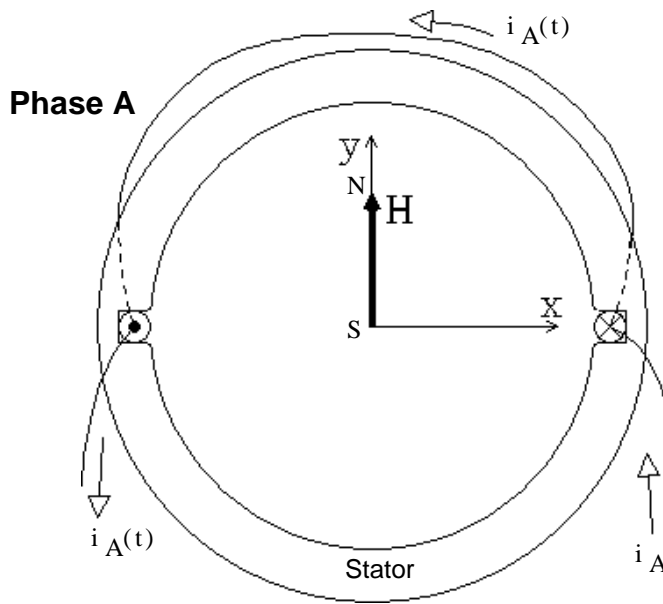

This is also an electromagnetic device  
Establishing a Rotating Magnetic Field

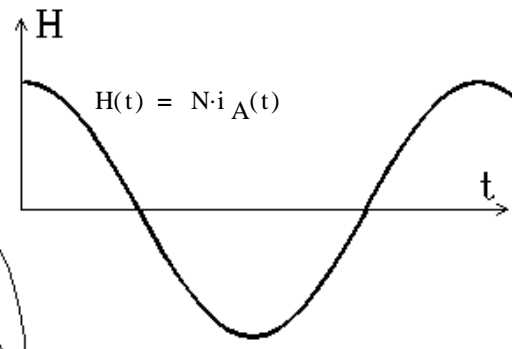

Field goes up and down, but no rotation

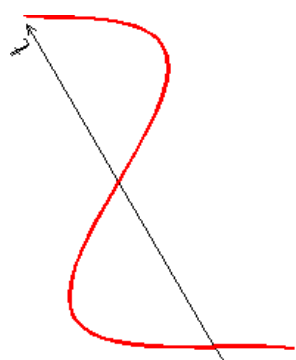

**Phase B**

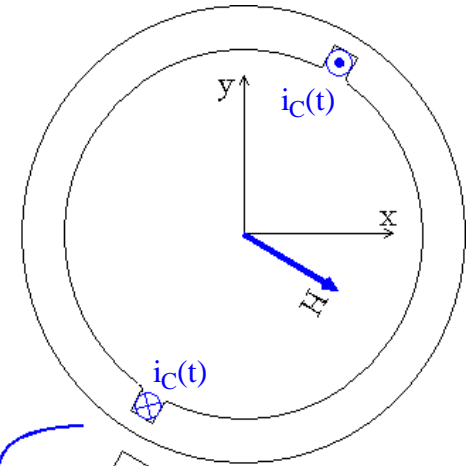
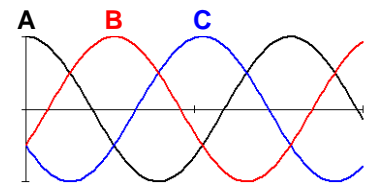
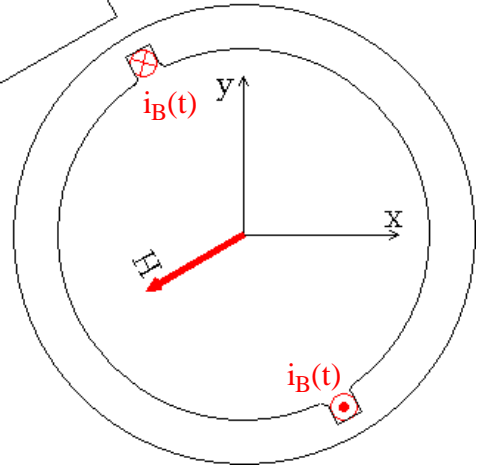

**Phase C**

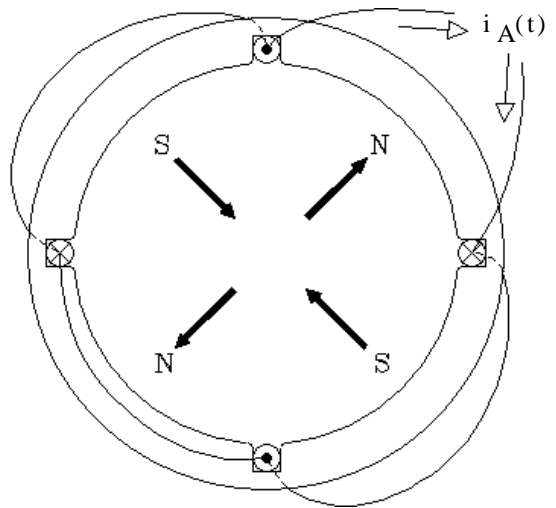
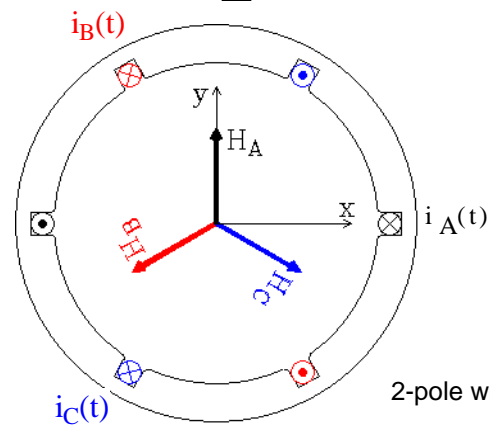
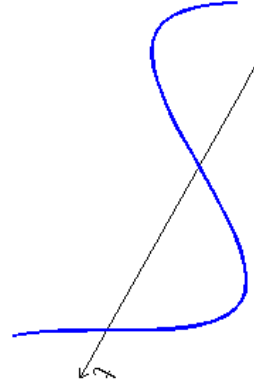

Phase A of a 4-pole winding

All 3 phases create a counterclockwise rotating magnetic field.

Speed of the Rotating Magnetic Field

Depends on the number of poles  $\omega = \frac{4 \cdot \pi \cdot f}{N_{\text{poles}}} = \frac{2 \cdot \left( 377 \cdot \frac{\text{rad}}{\text{sec}} \right)}{N_{\text{poles}}}$  for 60Hz systems

OR,  $n_m$  or  $n_{\text{sync}} = \frac{f \cdot \frac{2 \cdot \text{poles} \cdot 60 \cdot \text{sec}}{\text{cyc min}}}{N_{\text{poles}}} = \frac{7200 \cdot \text{rpm}}{N_{\text{poles}}}$  for 60Hz systems

The same stator windings are used for 3-phase Synchronous Machines and for Induction Motors.

In Synchronous Machines the stator is often called the "armature".

## Synchronous Generators & Motors

**Rotor** The rotors in Synchronous Machines are magnets which want to follow the rotating magnetic fields, usually DC electromagnets. The DC current usually flows through brushes and slip rings to reach the moving rotor. Sometimes the field current is generated and rectified right on the rotor. This DC field current is called the field current ( $I_f$ ).

Two types of rotors:

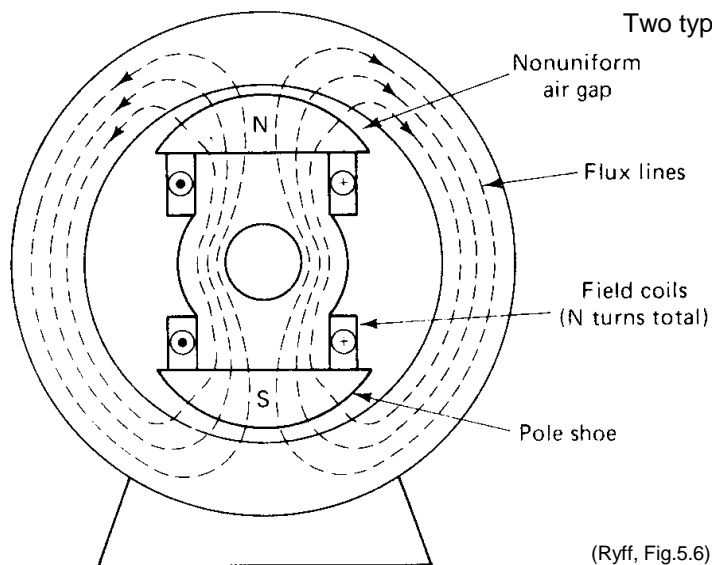

**2 Salient poles**

Common for a motor or generator with many poles

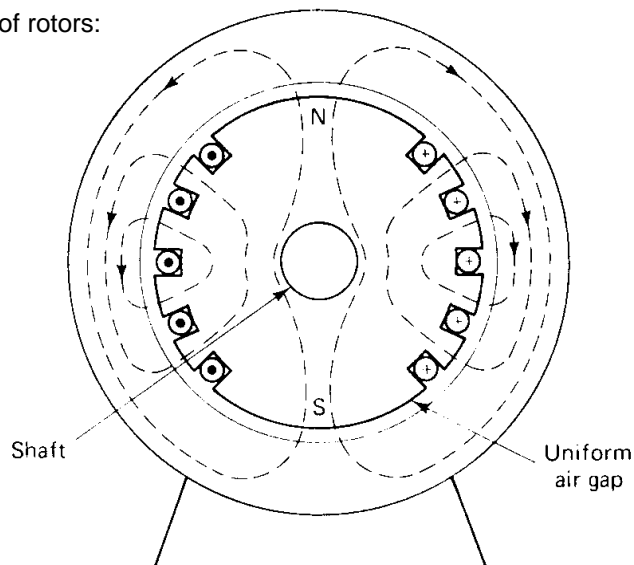

**2 Non-salient poles, Cylindrical rotor**

Common for a motor or generator with few poles

10-pole example

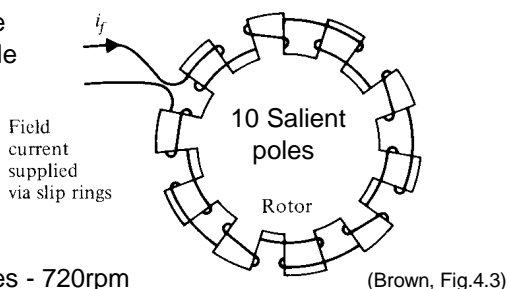

10-poles - 720rpm  
(fast for hydro)

Typically low-speed motor or water turbine driven generator. Typically short in length and large in diameter. (typ diameter is 1.5xlength)

(Brown, Fig.4.3)

Sometimes shown this way:

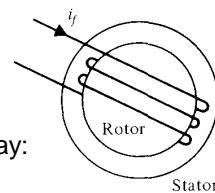

(Brown, Fig.4.2)

Typically high-speed motor or steam turbine driven generator, long and small diameter. (typ length is 3xdiameter)

2-poles - 3600rpm      4-poles - 1800rpm

## Motor

If the stator currents flow in from a 3-phase power source and the rotor is a magnet, the rotor will follow the rotating magnetic field at the synchronous speed (in sync with the rotating field). That would be a synchronous motor. However, when the magnetic rotor is spinning within the stator windings it will induce voltages on those windings, just like a generator. The induced voltages (called the back EMF,  $E_A$ ) will oppose the input voltages that caused the original currents to flow.

When the motor shaft is connected to a mechanical load (spins something which resists spinning), the rotor tries to slow down, but it only succeeds in lagging behind the rotating magnetic field a little (unless the motor is overloaded). When the rotor lags behind the field, the induced voltages ( $E_A$ )s will also lag the input voltages.

# Generator

If, instead of a mechanical load, the shaft of this same device is connected to a source of mechanical power which tries to make it spin faster than the synchronous speed, it will act as a generator. If the generator is connected to the power grid (as they usually are) the only way the mechanical power source (the prime mover) can increase the speed would be to push the frequency of the entire grid higher than 60 Hz -- not likely. So all it succeeds in doing is to make the rotor lead the rotating magnetic field a little and along with it the induced voltages ( $E_A$ )s will also lead the grid voltages..

Phasor diagrams of one phase.

We usually consider the the terminal or phase voltage ( $V_\phi$ ) be set and held constant by the entire power grid.

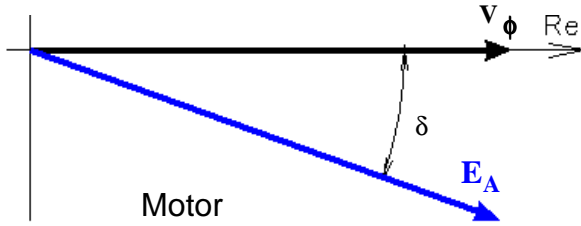

When operated as a motor, the induced armature voltage ( $E_A$ ) lags the terminal voltage,  $V_\phi$ .

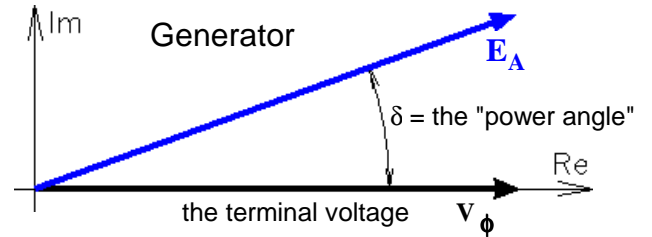

When operated as a generator, the induced armature voltage ( $E_A$ ) leads the terminal voltage,  $V_\phi$ .

The magnitude of the induced armature voltages ( $E_A$  for our phase) depends on the field current,  $I_f$ .  $I_f$  causes the field flux (called **excitation**). The DC current may come from an external supply or it may be generated on the rotor. Either way there are usually brushes and slip rings, if not for DC current, then for control of that current.

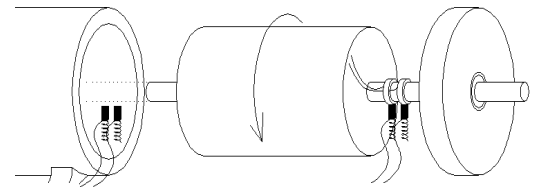

Slip rings and brushes used to connect a DC supply to the rotor. (brushes shown twice)

## Synchronous Generators

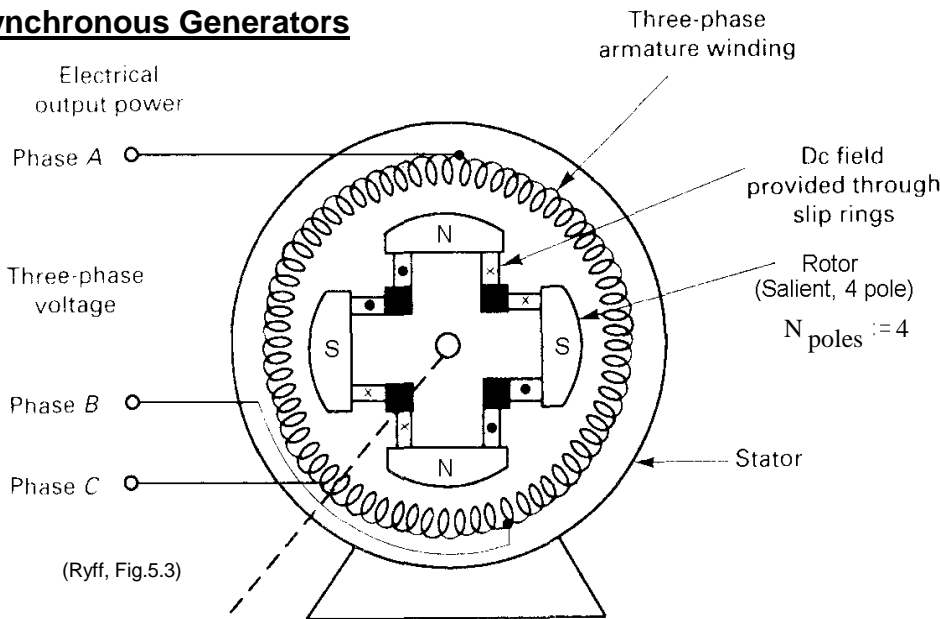

$$\omega = \frac{377 \cdot \frac{\text{rad}}{\text{sec}}}{2} = 188.5 \cdot \frac{\text{rad}}{\text{sec}}$$

$$n = \frac{7200 \cdot \text{rpm}}{4} = 1800 \cdot \text{rpm}$$

Mechanical input power = Torque x  $\omega$   
Prime mover (mechanical input power)

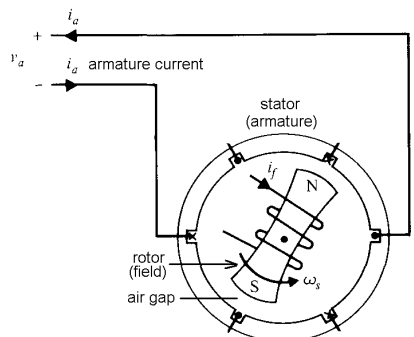

Stator (armature) winding

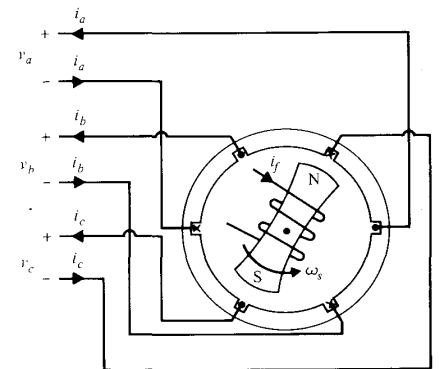

2-pole, 3-phase synchronous generator

(Brown, Fig.4.1)

## Electrical analysis on a per-phase basis

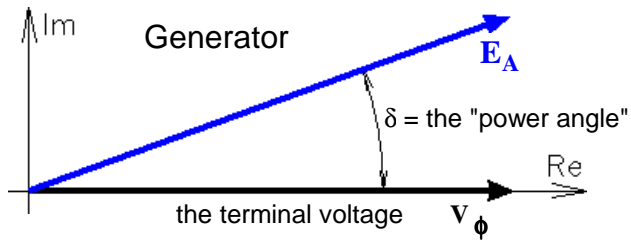

When operated as a generator, the induced armature voltage ( $E_A$ ) leads the terminal voltage,  $V_\phi$ .

The magnitude  $E_A$  depends on the DC field current,  $I_f$ .

### The electrical model of an armature winding

$X_s$  is the armature inductance  
(armature windings and leakage  
(magnetization))

$R_s$  is the armature winding resistance

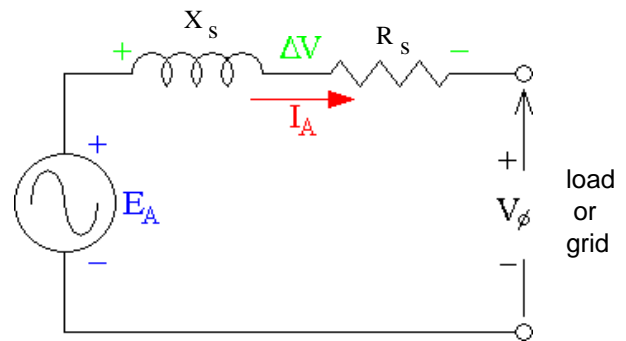

This is almost always simplified to this:  
(Especially in our class)

$$E_A = I_A \cdot j \cdot X_s + V_\phi$$

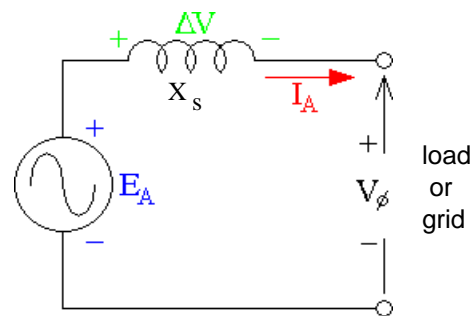

### Low, or Under-excited ( $\theta > 0$ )

Low DC field current

Low  $E_A$

Makes -Q

"Uses" Q like an  
inductive load

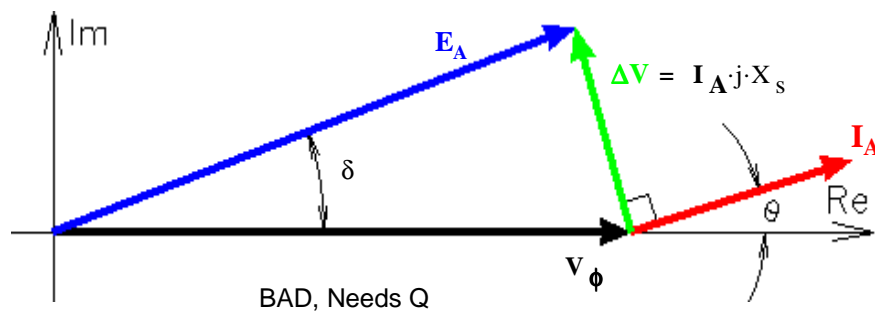

The **under-excited** condition, the current leads the terminal voltage,  $V_\phi$ . The generator supplies -Q (-VARs), that is, it absorbs +Q (+VARs), just like an inductive load. Usually not desirable.

### High, or Over-excited ( $\theta < 0$ )

Higher DC field current

High  $E_A$

Makes Q

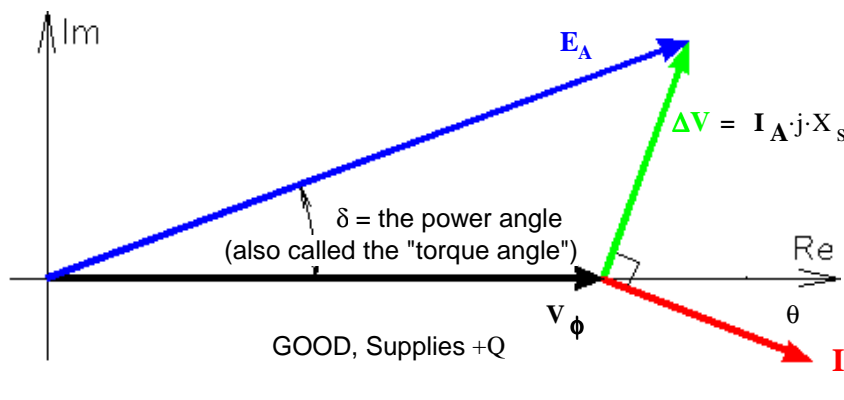

$$I_A = \frac{\Delta V}{j \cdot X_s} \quad \text{current lags, matching the need of most loads}$$

The **over-excited** condition, the current lags the terminal voltage,  $V_\phi$ . The generator supplies +Q (+VARs), that is, it absorbs -Q (-VARs), just like a capacitive load. Usually desirable.

## Important relations

Note: Voltages and currents are magnitudes, not complex numbers

The **signs** of the angles are **important!**

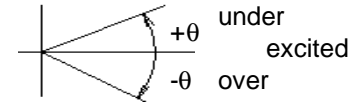
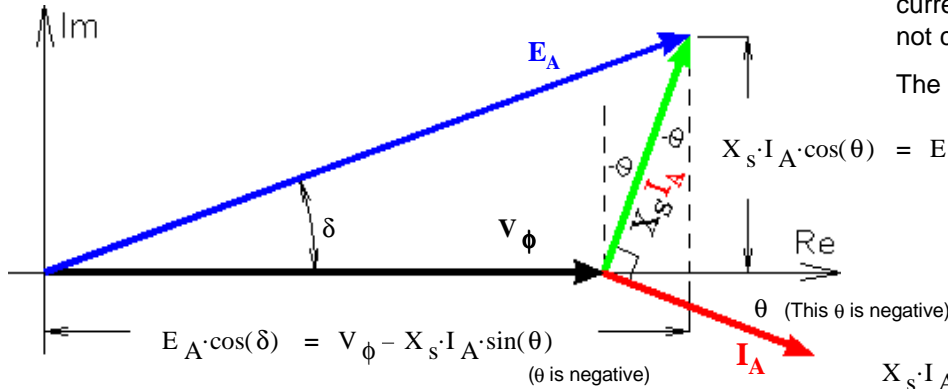

$$E_A \cdot \cos(\delta) = V_\phi - X_s \cdot I_A \cdot \sin(\theta)$$

( $\theta$  is negative)

$$X_s \cdot I_A \cdot \cos(\theta) = E_A \cdot \sin(\delta)$$

$$X_s \cdot I_A \cdot \cos(\theta) = E_A \cdot \sin(\delta)$$

$$-I_A \cdot \sin(\theta) = \frac{E_A \cdot \cos(\delta) - V_\phi}{X_s}$$

$$I_A \cdot \cos(\theta) = \frac{E_A \cdot \sin(\delta)}{X_s}$$

$$Q_{1\phi} = -V_\phi \cdot I_A \cdot \sin(\theta)$$

$$P_{1\phi} = V_\phi \cdot I_A \cdot \cos(\theta)$$

Important Equations

$$Q_{1\phi} = \frac{V_\phi \cdot E_A \cdot \cos(\delta) - V_\phi^2}{X_s}$$

$$P_{1\phi} = \frac{V_\phi \cdot E_A \cdot \sin(\delta)}{X_s}$$

$$E_A = V_\phi + I_A \cdot j \cdot X_s$$

$$\delta = \text{asin}\left(\frac{P_{1\phi} \cdot X_s}{V_\phi \cdot E_A}\right)$$

$$E_A = \sqrt{(V_\phi - X_s \cdot I_A \cdot \sin(\theta))^2 + (X_s \cdot I_A \cdot \cos(\theta))^2}$$

Be careful with the sign of  $\theta$ .

$$\text{asin} = \sin^{-1}$$

### Pullout power

If  $\delta$  reaches  $90^\circ$ , the generator will lose synchronization.

Pullout power is the maximum power a generator can produce for a given excitation, at  $\delta := 90\text{-deg}$

$$P_{po} = \frac{E_A \cdot V_\phi}{X_s} \cdot \sin(90\text{-deg}) = \frac{E_A \cdot V_\phi}{X_s}$$

### To Bring a Synchronous Generator "On Line"

1. Bring speed to the correct rpm so that the generator frequency matches the line frequency.
2. Adjust the field current,  $I_f$  so that the generator voltage matches the line voltage.
3. Readjust speed if necessary, check that the phases are in the correct sequence if necessary.
4. Wait until the phases align (0 volts difference between generator terminal and the line phase). Connect to the line at just the right moment.
5. Increase input torque to produce real electrical power and field current to produce reactive power.

Most (~99%) of the world's electrical energy is produced by 3-phase synchronous generators.

### Mechanical speed, torque, and power

$$\text{Shaft speed in rad/sec} \quad \omega_{\text{mech}} = \frac{4 \cdot \pi \cdot f}{N_{\text{poles}}} = \frac{2 \cdot \left(377 \cdot \frac{\text{rad}}{\text{sec}}\right)}{N_{\text{poles}}} \quad \text{for 60Hz systems}$$

$$\text{Shaft speed in rev/min} \quad n = \frac{f \cdot \frac{2 \cdot \text{poles} \cdot 60 \cdot \text{sec}}{\text{cyc} \cdot \text{min}}}{N_{\text{poles}}} = \frac{7200 \cdot \text{rpm}}{\text{poles}} \quad \text{for 60Hz systems}$$

$$\tau_{\text{mech}} \cdot \omega_{\text{mech}} = P_{3\phi} \quad (\text{electrical}) \quad \text{neglecting losses}$$

$$\tau_{\text{mech}} = \text{mechanical torque}$$

**Synchronous Motors**

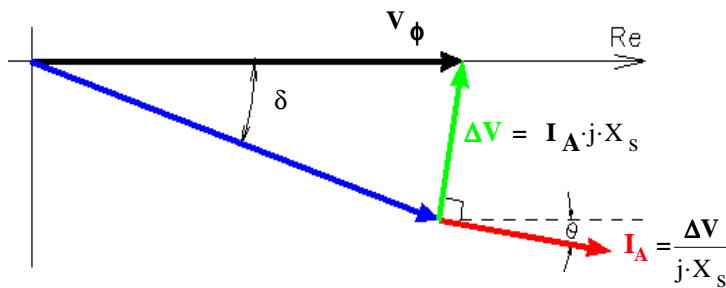
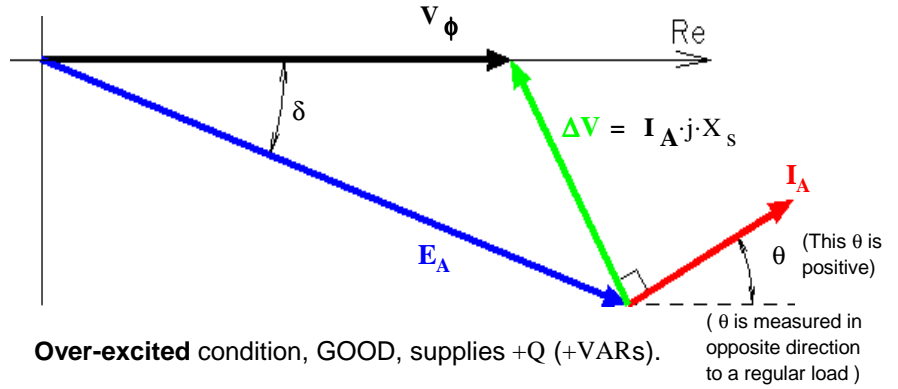
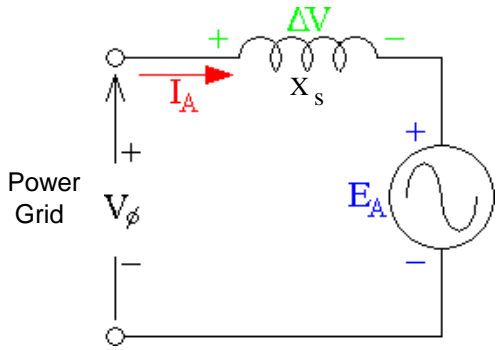

**Under-excited condition, BAD, absorbs +Q (+VARs).**

Important relations

$$E_A \cdot \sin(|\delta|) = X_s \cdot I_A \cdot \cos(\theta)$$

$$P_{1\phi} = \frac{E_A \cdot V_\phi}{X_s} \cdot \sin(|\delta|)$$

$$Q_{1\phi} = \frac{V_\phi^2 - E_A \cdot V_\phi \cdot \cos(\delta)}{X_s}$$

$$= V_\phi \cdot I_A \cdot \sin(-\theta)$$

$$Q_{1\phi} = V_\phi \cdot I_A \cdot \sin(-\theta)$$

( Bigger  $E_A$  makes Q negative (good) )

**Synchronous Condenser (Capacitor)**

A special case of the over-excited motor with no mechanical load (and neglecting friction)

An under-excited motor with no mechanical load (and neglecting friction) will look like an inductor. Called synchronous reactance.

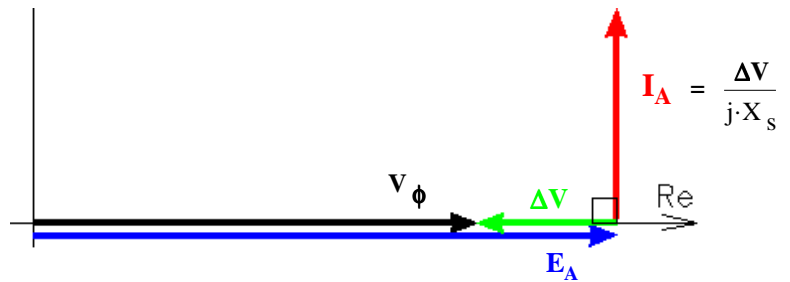
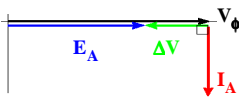

**Motor Connections and Changing the Direction of Rotation**

DO NOT alter the manufacturer's wiring within the motor, other than to change from Y to  $\Delta$  or reverse. And then follow directions carefully. Otherwise something like this could happen:

It is OK to change the connections between the power panel and the motor as long as you don't mess with the neutral and/or ground connections. Swapping any two phases from the power panel will reverse the direction of rotation. Works for both Y and  $\Delta$  connections

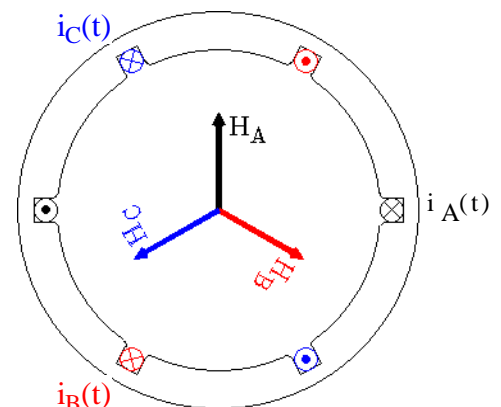
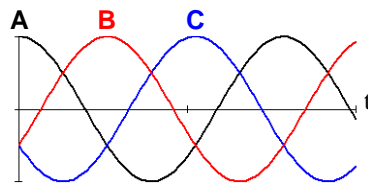
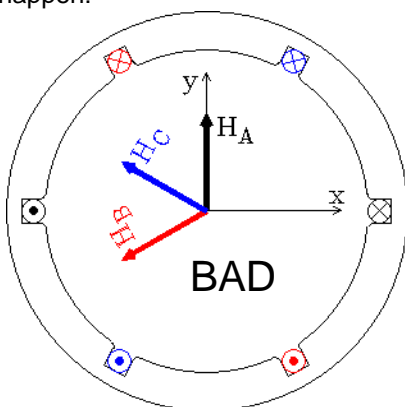

In steady-state synchronous operation, the rotor of a synchronous machine does not experience a changing magnetic flux so there are no core losses in the rotor and it can be made of solid ferromagnetic material. The stator, on the other hand, *does* experience a changing magnetic flux (at 60 Hz) so there are both hysteresis and eddy-current core losses in the stator. The stator is constructed of laminated, siliconized material to minimize the eddy currents.

### Stator windings in practice

The nonlinearity of the stator core also causes the stator current to be nonsinusoidal, including a significant third-harmonic (just like in a transformer). To reduce the harmonics, the phase windings are designed to overlap each other a little and don't always span exactly 180° of flux.

### Effect on the network (grid)

Our analysis regularly assumes that the generator feeds an "infinite" network bus. Then we can assume the network voltage, or the terminal voltage, is constant in magnitude, frequency and phase (The slack-bus idea). In reality, large generators *do* affect the network (the larger the generator, the larger the effect). Increasing the prime-mover torque will raise the network voltage (especially in the local area) and slightly increase the entire network frequency. Matching the generation of reactive power to the local needs will help to optimize the network power flow.

### Damper Bars

The rotor of an *induction* motor includes a number of thick conductors called "rotor bars". Current is induced in these bars because the rotor normally turns at speed which is slower than the synchronous speed (the speed of the rotating flux caused by the stator windings). The interaction between the induced current and the rotating flux provides the motor torque.

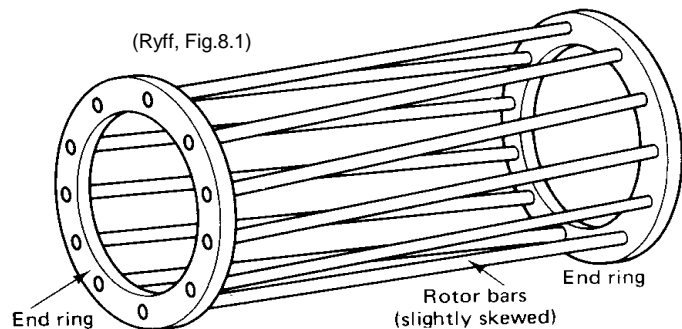

Synchronous machines usually have very similar bars in their rotors. In steady-state synchronous operation, they have no effect. The purpose of these bars is to resist, or dampen, transients. Currents will be induced in these windings when the stator current magnitudes change or when the input rotational shaft speed changes. By Lenz's law, those currents will be induced in a direction to oppose the change that caused them. In solid iron rotors, the eddy currents have the same effect. Without damping, the shaft speed can oscillate.

See textbook section 5.11, p.243 for more details.

See also textbook  
fig 5.41, p.245

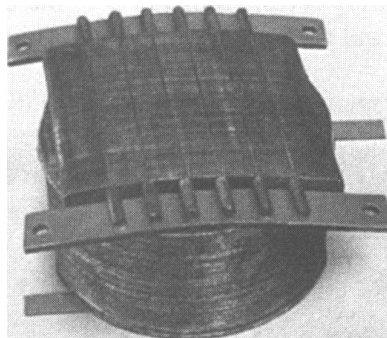

(Ryff, Fig.10.3)

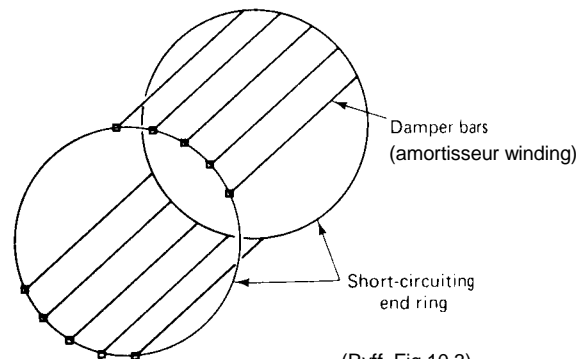

(Ryff, Fig.10.3)

Note: These notes and Chapter 5 of our textbook assumes that the DC supply of the field current is robust enough to withstand high voltage transients. It also assumes the source resistance and the field winding resistance are so small that the field winding itself can perform the transient damping function. It is more reasonable to assume that the synchronous machine is constructed with damper bars, but the results of the different assumptions is about the same.



Transient Conditions

The armature currents normally create a rotating flux in sync with the rotor motion and the flux through the rotor is constant. These steady-state currents see large synchronous reactances ( $X_s$ ) due in large part to the low reluctance of the rotor.  $X_s$  can be 1 per-unit based on the machine's bases. When armature current magnitudes change, the armature flux has to change as well. A rotor with damping bars (or other low-resistance windings or eddy current paths), will strongly resist any changes in flux through the rotor, so much of the changing flux will go around the rotor, taking a much higher reluctance path. A higher reluctance path results in a lower inductance and a lower reactance.

$X_s$  = steady-state synchronous reactance, nearly all flux goes through rotor

$X''_s$  = sub transient synchronous reactance, no additional flux goes through rotor  
first few cycles only

$$= \frac{X_s}{10} \text{ to } \frac{X_s}{4}$$

$X'_s$  = transient synchronous reactance, some additional flux goes through rotor  
after first few cycles until new steady-state.

$$\simeq 2 \cdot X''_s$$

Variations of the magnetizing reactance in salient pole machines

A large part of the synchronous reactance ( $X_s$ ) is the magnetizing reactance ( $X_m$ ) and arises from the rotating magnetic flux produced by the armature current. Our analysis up to this point, assumes that the rotating flux depends proportionally on the current magnitude alone. That, in turn, assumes that the magnetic reluctance is the same for all angles of the rotor. This is a bad assumption for a salient-pole rotor. The reluctance along the "direct" or "d"-axis of the rotor is less than the reluctance along the "quadrature" or "q"-axis.

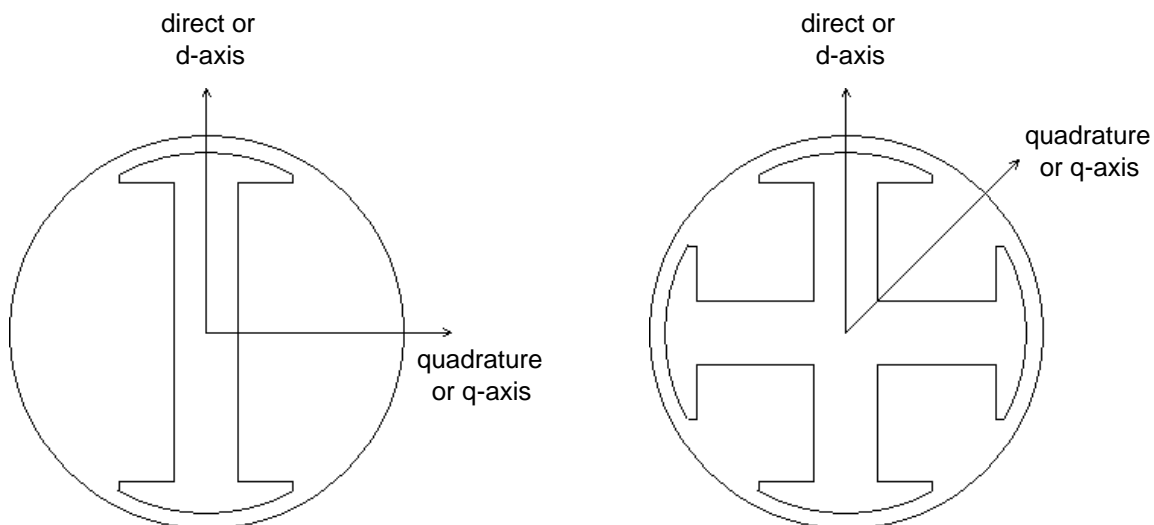

To fully analyze the salient-pole machine, the armature magnetizing reactance ( $X_m$ ) needs to be broken up into  $X_{md}$  and  $X_{mq}$ , corresponding to the direct and quadrature axes. The armature voltages and currents are then also broken up into  $v_d$  and  $v_q$ , and  $i_d$  and  $i_q$ , respectively. This is beyond the scope of our class.

# ECE 3600 Synchronous Generator & Motor Examples

A. Stolp  
10/25/11  
rev10/9/14,  
10/3/22

## Ex. 1

(F08 E2) A 60 Hz, 4-pole, 3-phase synchronous generator supplies 90 kW of power to a 4 kV bus. The synchronous reactance is 50 Ω/phase. The generator emf is 3 kV. Find the following.

a) The power angle,  $\delta$ .

givens  $f := 60 \cdot \text{Hz}$        $N_{\text{poles}} := 4$       Assume Y-connected:  $V_{\phi} := \frac{4 \cdot \text{kV}}{\sqrt{3}}$   
 Otherwise  $E_A$  would be very low.  
 $X_s := 50 \cdot \Omega$        $E_A := 3 \cdot \text{kV}$        $P_{3\phi} := 90 \cdot \text{kW}$

$$P_{1\phi} := \frac{P_{3\phi}}{3} \quad P_{1\phi} = 30 \cdot \text{kW} = \frac{V_{\phi} \cdot E_A \cdot \sin(\delta)}{X_s} \quad \delta := \text{asin}\left(\frac{P_{1\phi} \cdot X_s}{V_{\phi} \cdot E_A}\right) \quad \delta = 12.5 \cdot \text{deg}$$

b) The total reactive power generated.

$$Q_{1\phi} = \frac{V_{\phi} \cdot E_A \cdot \cos(\delta) - V_{\phi}^2}{X_s} \quad Q_{3\phi} = 3 \cdot \frac{V_{\phi} \cdot E_A \cdot \cos(\delta) - V_{\phi}^2}{X_s} = 85.83 \cdot \text{kVAR}$$

c) Find a new magnitude of the generator emf so that  $Q := 45 \cdot \text{kVAR}$

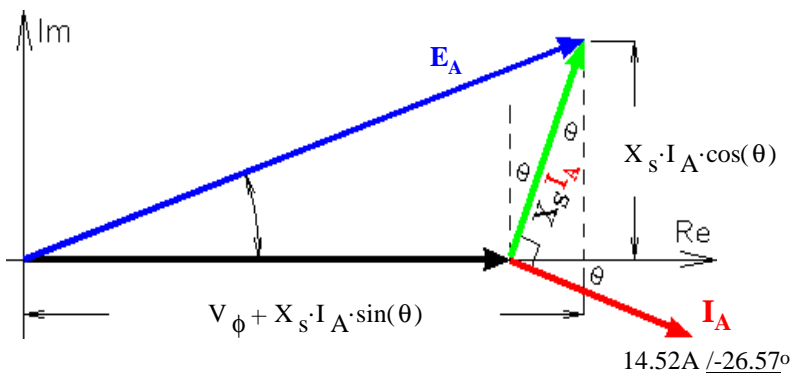

$$Q_{1\phi} := \frac{Q}{3} \quad S_{1\phi} := \sqrt{P_{1\phi}^2 + Q_{1\phi}^2}$$

$$I_A := \frac{S_{1\phi}}{V_{\phi}} \quad I_A = 14.52 \cdot \text{A}$$

$$\theta := \text{atan}\left(\frac{Q_{1\phi}}{P_{1\phi}}\right) \quad \theta = 26.57 \cdot \text{deg}$$

Notice that  $\theta$  is positive in the downward direction, contrary to the notes. Also notice how that affects the figure at left. Know what you're doing, don't just use formulas!

by Pythagorean theorem:  $E_A := \sqrt{(V_{\phi} + X_s \cdot I_A \cdot \sin(\theta))^2 + (X_s \cdot I_A \cdot \cos(\theta))^2}$        $E_A = 2.713 \cdot \text{kV}$

OR  $I_A := I_A \cdot e^{-j\theta}$        $E_A := V_{\phi} + I_A \cdot (j \cdot X_s)$        $E_A = |E_A| = 2713 \cdot \text{V}$        $\delta = \arg(E_A) = 13.851 \cdot \text{deg}$

d) The shaft speed.

$$n := \frac{7200 \cdot \text{rpm}}{N_{\text{poles}}} \quad n = 1800 \cdot \text{rpm} \quad \omega_m := n \cdot \frac{2 \cdot \pi \cdot \text{rad}}{\text{rev}} \cdot \left(\frac{\text{min}}{60 \cdot \text{sec}}\right) \quad \omega_m = 188.496 \cdot \frac{\text{rad}}{\text{sec}}$$

$$\text{OR} \quad \omega_m = \frac{\left(\frac{377 \cdot \text{rad}}{\text{sec}}\right)}{\left(\frac{N_{\text{poles}}}{2}\right)} = 188.5 \cdot \frac{\text{rad}}{\text{sec}}$$

e) The shaft torque.

Often called the "Prime-mover torque"

$$P_{3\phi} = \omega T \quad T := \frac{P_{3\phi}}{\omega_m} \quad T = 477.5 \cdot \text{N} \cdot \text{m}$$

f) The shaft torque is decreased to half the value found in part e). What is the new P and Q?

$$P'_{3\phi} := \frac{1}{2} \cdot P_{3\phi} \quad P'_{3\phi} = 45 \cdot \text{kW} \quad \delta := \text{asin}\left(\frac{P'_{3\phi} \cdot X_s}{3 \cdot V_{\phi} \cdot E_A}\right) \quad \delta = 6.87 \cdot \text{deg}$$

$$Q_{3\phi} = 3 \cdot \frac{V_{\phi} \cdot E_A \cdot \cos(\delta) - V_{\phi}^2}{X_s} = 53.23 \cdot \text{kVAR}$$

Ex. 2

(F09 Fin) You make the following measurements on a 3-phase, Y-connected, synchronous generator.

$P_{3\phi} := 120 \cdot \text{kW}$        $V_{LL} := 480 \cdot \text{V}$        $I_L := 160 \cdot \text{A}$        $X_s := 1.2 \cdot \Omega$

Unfortunately, you don't know the phase angle of current.

a) Draw a phasor diagram of one of the two possible interpretations of these numbers.

Find the induced armature voltage ( $E_{af}$ ) and the power angle,  $\delta$ .       $E_A = ?$        $\delta = ?$

My first assumption:  $I_L$  leads  $V_T$

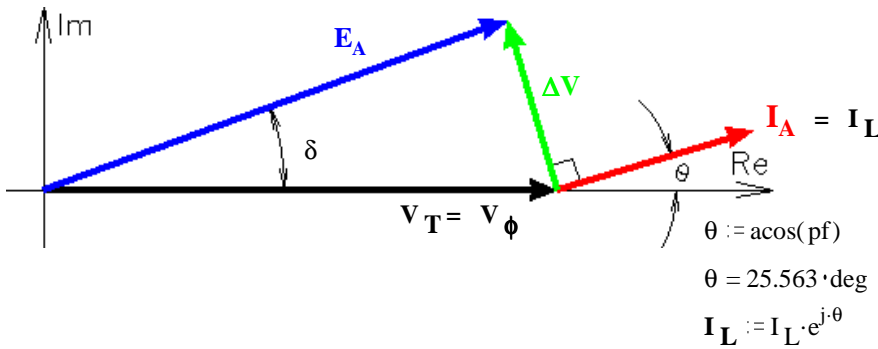

$V_T := \frac{V_{LL}}{\sqrt{3}}$        $V_T = 277.13 \cdot \text{V} = V_\phi$   
 $P_{1\phi} := \frac{P_{3\phi}}{3}$        $P_{1\phi} = 40 \cdot \text{kW}$   
 $\text{pf} := \frac{P_{1\phi}}{I_L \cdot V_T}$        $\text{pf} = 0.902$

$E_A := V_T + I_L \cdot (j \cdot X_s)$        $E_A = |E_A| = 260.28 \cdot \text{V}$        $\delta = \arg(E_A) = 41.718 \cdot \text{deg}$

b) Draw a phasor diagram of other possible interpretation of these numbers.

Find the induced armature voltage ( $E_{af}$ ) and the power angle,  $\delta$ .       $\delta = ?$

My second assumption:  $I_L$  lags  $V_T$

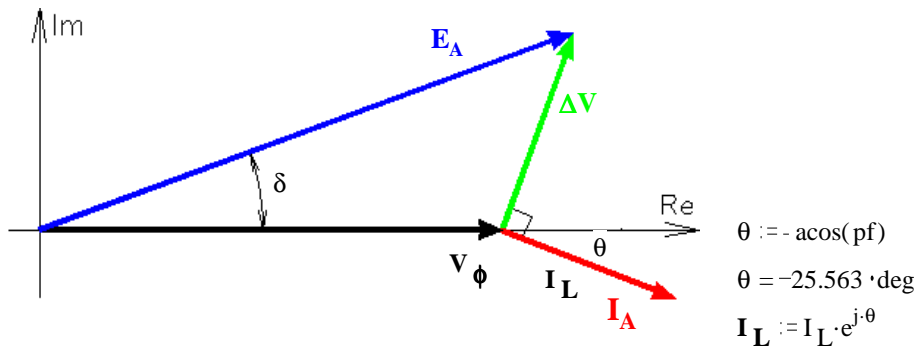

$E_A := V_T + I_L \cdot (j \cdot X_s)$        $E_A = |E_A| = 399.48 \cdot \text{V}$        $\delta = \arg(E_A) = 25.695 \cdot \text{deg}$

c) A traveling carnival uses a combination of this generator and the local power company to run its load, mainly induction motors. When the generator is connected to the carnival's power distribution network, it supplies half of the required power, but the current from the power company only decreases by about 30%. Which of the calculations above is most likely correct?

Assumption in a)

Give me the reasoning behind your answer (no calculations required).

The induction motors represent a lagging pf load, they use lots of VARs. If the local generator were supplying those VARs, then the current would go down by about half and quite possibly more. The small reduction in current implies that the generator also consumes VARs (creates negative VARs). That is condition a).

d) What do you change at the generator to reduce the current flow from the power company?

Tell me what you adjust and if you turn it up or down.

Turn up the field current.

**Ex. 3**

**ECE 3600 Synchronous Mach. Examples p3**

A 60 Hz, 2-pole, Y-connected, 3-phase synchronous generator supplies 15 MW of power to a 18 kV bus. The synchronous reactance is 6 Ω/phase. The magnitude of the generator emf equals the magnitude of the bus voltage.

givens  $V_\phi := \frac{18 \cdot \text{kV}}{\sqrt{3}}$   $V_\phi = 10.392 \cdot \text{kV}$   $X_s := 6 \cdot \Omega$   $P_{1\phi} := \frac{15 \cdot \text{MW}}{3}$   $P_{1\phi} = 5 \cdot \text{MW}$   
 $E_A := V_\phi$

Find:  
 a) The power angle,  $\delta$ .  $P_{1\phi} = \frac{E_A \cdot V_\phi}{X_s} \cdot \sin(\delta)$   $\delta := \text{asin}\left(\frac{P_{1\phi} \cdot X_s}{E_A \cdot V_\phi}\right)$   $\delta = 16.13 \cdot \text{deg}$

b) The complex phase current, (Assume the bus voltage phase angle is 0°).

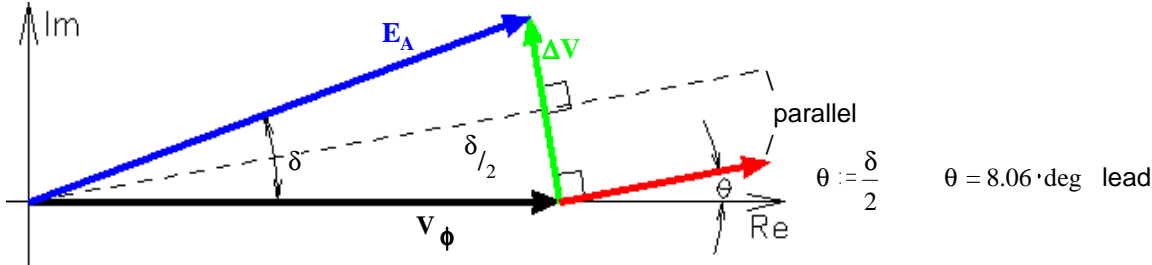

$P_{1\phi} = V_\phi \cdot I_A \cdot \cos(\theta)$   $I_A := \frac{P_{1\phi}}{V_\phi \cdot \cos(\theta)}$   $I_A = 485.9 \cdot \text{A}$

c) The magnitude and direction of reactive power.

$Q_{3\phi} := 3 \cdot V_\phi \cdot I_A \cdot \sin(-\theta)$   $Q_{3\phi} = -2.125 \cdot \text{MVAR}$

Since the current leads the voltage, this generator absorbs reactive power (produces -VARs)

**Ex. 4**

A 60-Hz, three-phase, 6-pole, Δ-connected synchronous motor is connected to 480 V and produces 80 hp. The motor draws minimum current with an excitation voltage of  $E_A = 520 \text{ V}$  per phase. Mechanical losses are 5hp .

givens  $N_{\text{poles}} := 6$   $V_\phi := 480 \cdot \text{V}$   $P_{3\phi} := 80 \cdot \text{hp} + 5 \cdot \text{hp}$   $E_A := 520 \cdot \text{V}$   
 $P_{1\phi} := \frac{85 \cdot \text{hp} \cdot 745.7 \cdot \text{W}}{3 \cdot \text{hp}}$   $P_{1\phi} = 21.1 \cdot \text{kW}$

Determine the following:

a) The current.

Minimum current implies  $\text{pf} := 1$  so...

$I_A := \frac{P_{1\phi}}{V_\phi}$   $I_A = 44.02 \cdot \text{A}$

b) The line current.  $I_L := \sqrt{3} \cdot I_A$   $I_L = 76.24 \cdot \text{A}$

c) The synchronous reactance.

by Pythagorean theorem:  $I_A \cdot X_s = \sqrt{E_A^2 - V_\phi^2}$   $X_s := \frac{\sqrt{E_A^2 - V_\phi^2}}{I_A}$   $X_s = 4.544 \cdot \Omega$

d) The torque.

$\omega_{\text{mech}} := \frac{4 \cdot \pi \cdot f}{N_{\text{poles}}}$   $T_{\text{mech}} = \frac{80 \cdot \text{hp} \cdot 745.7 \cdot \text{W}}{\omega_{\text{mech}}} = 475 \cdot \text{N} \cdot \text{m}$

e) The rotor power angle.

$\delta = \text{acos}\left(\frac{V_\phi}{E_A}\right) = 22.62 \cdot \text{deg}$

f) The maximum power this motor could provide at this excitation voltage.

$\delta := 90 \cdot \text{deg}$   $P_{3\phi} = 3 \cdot \frac{E_A \cdot V_\phi}{X_s} \cdot \sin(\delta) \cdot \frac{1 \cdot \text{hp}}{745.7 \cdot \text{W}} - 5 \cdot \text{hp} = 216 \cdot \text{hp}$  Note: The current rating of the motor may be exceeded at this load.

### Ex. 5

### ECE 3600 Synchronous Mach. Examples p4

(F09 E2, p4) An industrial plant is powered from a 480-V, 3-phase bus and currently draws 60 kW at a power factor of 0.8 lagging. A new mill is to be added at the plant. This mill requires a shaft torque of 600 Nm at 1200 rpm. Your job is to specify a motor which will run the mill and correct the plant power factor at the same time. Be sure to specify the type of motor including the number of poles. Tell me how the motor should be connected to the bus (This is an arbitrary decision here, but it will affect many of your other answers). Specify its minimum hp, voltage, and current ratings. Tell me what the back emf should be. You may assume the synchronous reactance is 1 Ω/phase and that losses are negligible.

$$\begin{aligned} \text{Plant, as is: } P_{3\phi} &:= 60 \cdot \text{kW} & P_{1\phi} &:= \frac{P_{3\phi}}{3} & P_{1\phi} &= 20 \cdot \text{kW} & \text{pf} &:= 0.8 \\ S_{1\phi} &:= \frac{P_{1\phi}}{\text{pf}} & S_{1\phi} &= 25 \cdot \text{kVA} & Q_{1\phi} &:= \sqrt{S_{1\phi}^2 - P_{1\phi}^2} & Q_{1\phi} &= 15 \cdot \text{kVAR} \end{aligned}$$

Motor basics

$$\begin{aligned} N_{\text{poles}} &:= \frac{7200}{1200} & N_{\text{poles}} &= 6 & \omega_{\text{mech}} &:= \frac{4 \cdot \pi \cdot f}{N_{\text{poles}}} & \omega_{\text{mech}} &= 125.7 \cdot \frac{\text{rad}}{\text{sec}} & \left( \frac{377}{3} \right) \end{aligned}$$

Use a 6-pole synchronous motor

$$T_{\text{mech}} := 600 \cdot \text{N} \cdot \text{m} \quad \text{motor power} = P_{m3\phi} = T_{\text{mech}} \cdot \omega_{\text{mech}} = 75.398 \cdot \text{kW} \quad 1 \cdot \text{hp} = 745.7 \cdot \text{W}$$

$$T_{\text{mech}} \cdot \omega_{\text{mech}} \cdot \frac{1 \cdot \text{hp}}{745.7 \cdot \text{W}} = 101.111 \cdot \text{hp} = \text{min hp rating}$$

$$P_{m1\phi} := \frac{T_{\text{mech}} \cdot \omega_{\text{mech}}}{3} \quad P_{m1\phi} = 25.133 \cdot \text{kW}$$

$$\text{To fix the plant pf, } Q_{m1\phi} := -Q_{1\phi} \quad Q_{m1\phi} = -15 \cdot \text{kVAR}$$

$$\text{Phase angle of the current: } \theta := \text{atan} \left( \frac{-Q_{m1\phi}}{P_{m1\phi}} \right) \quad \theta = 30.83 \cdot \text{deg}$$

$$\text{If you select Y-connected } V_{\phi} := \frac{480 \cdot \text{V}}{\sqrt{3}} \quad V_{\phi} = 277.1 \cdot \text{V} = \text{min voltage rating}$$

$$\text{Current per phase: } I := \frac{\sqrt{P_{m1\phi}^2 + Q_{m1\phi}^2}}{V_{\phi}} \quad I = 105.61 \cdot \text{A} = \text{min current rating}$$

$$X_s := 1 \cdot \Omega \quad \Delta V := I \cdot e^{j\theta} \cdot X_s \cdot j \quad \Delta V = -54.127 + 90.69j \cdot \text{V}$$

$$\text{motor back emf } E_A := V_{\phi} - \Delta V \quad E_A = 331.255 - 90.69j \cdot \text{V} \quad |E_A| = 343.44 \cdot \text{V} = \text{required motor emf}$$

$$\delta = \arg(E_A) = -15.311 \cdot \text{deg} \quad (\text{unneeded})$$

$$\text{If you select } \Delta\text{-connected } V_{\phi} := 480 \cdot \text{V} \quad V_{\phi} = 480 \cdot \text{V} = \text{min voltage rating}$$

$$\text{Current per phase: } I := \frac{\sqrt{P_{m1\phi}^2 + Q_{m1\phi}^2}}{V_{\phi}} \quad I = 60.98 \cdot \text{A} = \text{min current rating}$$

$$X_s := 1 \cdot \Omega \quad \Delta V := I \cdot e^{j\theta} \cdot X_s \cdot j \quad \Delta V = -31.25 + 52.36j \cdot \text{V}$$

$$\text{motor back emf } E_A := V_{\phi} - \Delta V \quad E_A = 511.25 - 52.36j \cdot \text{V} \quad |E_A| = 513.92 \cdot \text{V} = \text{required motor emf}$$

1. a) List at least 3 different synchronous motor speeds in the US, in rpm. b

b) List at least 3 different synchronous motor speeds in a country with 50-Hz power, in rpm.

c) Could a motor designed to operate from 60-Hz power safely operate at 50 Hz? If yes, should you modify other operational parameters of the motor? Specify what parameters should also change and by how much.

2. Generators are designed differently depending on the mechanical power source.

a) Name 2 mechanical power sources typically used to drive 2-pole generators?

1. 2.

b) Name a mechanical power source typically used to drive 4-pole generators?

c) Name a mechanical power source typically used to drive 10-pole generators?

3. In a 6-pole machine, what are the 6 poles?  
Show them on as magnetic field vectors.

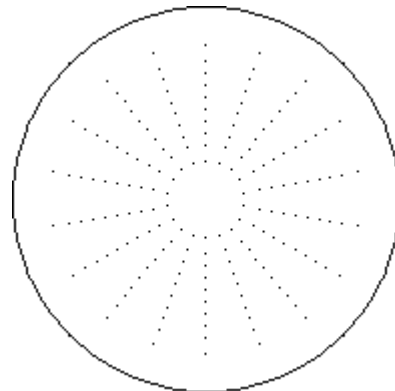

4. A hydro-electric turbine and generator is 90% efficient. The "head" is 100 ft. That means the surface height of water is 100 ft (30.48m) above the turbine. How much water must flow through the turbine to produce 10MW of electrical power?

$$P_{\text{out}} := 10 \cdot \text{MW} \quad 100 \cdot \text{ft} = 30.48 \cdot \text{m} \quad g = 9.807 \cdot \frac{\text{m}}{\text{sec}^2} \quad \text{Density of water} = \rho := 1 \cdot \frac{\text{kg}}{\text{liter}} \quad 1 \cdot \text{ft}^3 = 28.317 \cdot \text{liter}$$

$$\text{watt} = 1 \cdot \frac{\text{joule}}{\text{sec}} = 1 \cdot \frac{\text{N} \cdot \text{m}}{\text{sec}}$$

## ECE 3600 homework SG1 p2

5. Your 2-pole generator is producing 120MW of electrical power. Assume it's ideal, so there are no mechanical or electrical power losses in the generator.

a) Find the shaft speed in both rad/sec and rpm.      givens    $f := 60\text{-Hz}$     $N_{\text{poles}} := 2$     $P_{3\phi} := 120\text{-MW}$

b) how many hp does the mechanical power source provide?

c) How much torque is being applied to the input shaft?

d) Find the required shaft diameter for a 2x factor of safety. Material & mechanical properties are given below.

Yield strength of high-quality carbon steel =  $\sigma_{\text{yield}} := 400000000 \cdot \frac{\text{N}}{\text{m}^2}$

Shear yield stress =  $\tau_{\text{yield}} := 75\% \cdot \sigma_{\text{yield}}$     $\tau_{\text{yield}} = 3 \cdot 10^8 \cdot \frac{\text{N}}{\text{m}^2}$

For a 2x factor of safety, do not exceed  $1.5 \cdot 10^8 \cdot \frac{\text{N}}{\text{m}^2}$

Moment of Inertia of cylindrical shaft =  $J = \frac{\pi \cdot r^4}{2}$        $r = \text{radius of the shaft (in meters)}$        $1 \cdot \text{m} = 39.37 \cdot \text{in}$

Shear stress  $\tau = \frac{T_{\text{mech}} \cdot r}{J}$       For a 2x factor of safety, do not exceed  $\tau = 1.5 \cdot 10^8 \cdot \frac{\text{N}}{\text{m}^2}$

e) The prime mover of this generator is a steam turbine. The turbine is part of a 40% efficient Rankine cycle  
How much natural gas are you burning per hour (in cubic feet)?

A "therm" is approximately equivalent to 100 cubic feet of gas and provides about 100,000 BTU .

1 BTU = 1055 ·joule (British Thermal Unit)

**ECE 3600 homework SG1 p3**

f) Natural gas costs about \$3 per decatherm (ten therm) or MMBtu (one million BTU).  
How much are you spending on natural gas per hour? Per day?

e) If you sell the electrical power for 6 cents per kWh (1000 Watt-hours), what is your gross revenue per day?

g) How much heat energy must you get rid of every hour?

h) According to the Pacific Gas and Electric Company emissions rate, burning natural gas produces on average 13.446 pounds (6.099 kg) of carbon dioxide per therm. How many pounds of CO<sub>2</sub> are you producing each hour?

**Answers**

1. a)  $\frac{3600 \cdot \text{rpm}}{\text{any\_integer}}$       b)  $\frac{3000 \cdot \text{rpm}}{\text{any\_integer}}$       c) Yes, but derate voltage and motor power by factor of  $\frac{5}{6}$

2. a) Gas-turbine      Steam-turbine      b) Internal combustion engine      c) Hydro-turbine

3. N, S, N, S, N, S

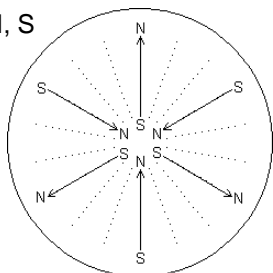

4.  $37.2 \cdot \frac{\text{k-liter}}{\text{sec}} = 1300 \cdot \text{cfs} = 2600 \cdot \frac{\text{acre} \cdot \text{ft}}{\text{day}}$

5. a)  $377 \cdot \frac{\text{rad}}{\text{sec}}$       3600-rpm      b) 161,000-hp      c) 32-kN·m

d) 8.7-in      e) million  $\cdot \frac{\text{ft}^3}{\text{hour}}$       f) \$3.1k/hour      \$74k/day

e) \$173k/day      g) 614-M·BTU      h) 138-k



Name \_\_\_\_\_ ECE 3600 homework SG2 Due: Wed, 2/29/23

1. A 60 Hz, 4-pole, 3-phase synchronous generator supplies 90 kW of power to a 4 kV bus. The synchronous reactance is  $50 \Omega$ /phase. The generator emf is 3 kV. Find the following.

d

a) The power angle,  $\delta$ .

b) The total reactive power generated.

c) Find a new magnitude of the generator emf so that  $Q := 45 \cdot \text{kVAR}$

## ECE 3600 homework SG2 p2

2. A 3-phase synchronous generator operates onto a grid bus of voltage 12 kV (line value). The synchronous reactance is  $5 \Omega/\text{phase}$ . The magnitude of the generator emf equals the magnitude of the bus voltage.

The machine delivers 18 MW to the grid. Find:

a) The power angle,  $\delta$ .

b) The complex phase current, (Assume the bus voltage phase angle is  $0^\circ$ ).

c) The magnitude and direction of reactive power.

3. A 60 Hz, 2-pole, 3-phase synchronous generator supplies power to a 12.5 kV bus. The synchronous reactance is  $4 \Omega/\text{phase}$ . The generator emf is  $7 \text{ kV} \angle 20^\circ$  (the angle is referenced to the terminal voltage). Find the following.

a) The total power generated.

b) The total reactive power generated.

**ECE 3600 homework SG2 p3**

c) The shaft torque from the prime mover, neglecting friction.

d) Increase the magnitude of the generator emf so that  $Q := 0 \cdot \text{VAR}$ . The prime mover torque does not change.

Note: If the prime mover torque doesn't change, neither does  $P$ .  $\delta$  can change.

e) The new power angle,  $\delta$ .

f) Increase the magnitude of the generator emf so that  $Q := 9 \cdot \text{MVAR}$ .

g) The new power angle,  $\delta$ .

## ECE 3600 homework SG2 p4

4. A 3-phase, synchronous generator is not electrically connected to anything. The prime mover is spinning the generator at 3600 rpm. The input torque is 30 Nm. When the field current is 10 A, DC, the terminal voltage is 1100 V.

The field current is raised to 20 A, and the terminal voltage goes up to 2200 V.

The generator is now Y-connected to a 3.6 kV, 60 Hz, bus. The line current is measured at 4 A.

The input torque is still 30 Nm, just enough to overcome rotational losses.

a) What is the power angle and/or how much power is being generated?

b) Find the synchronous reactance.  $X_s = ?$

c) Find the total reactive power generated.

d) The prime mover torque is increased to  $\tau_{in} := 530 \cdot \text{N} \cdot \text{m}$  Find the generated electrical power  $P = ?$

The prime mover torque is held at this value for the rest of the problem.

e) Find the power angle.  $\delta = ?$

f) Find the total reactive power generated.

g) The generator operator is told to produce 30 kVAR , no change in real power. Find the required  $E_A$ .

h) What does the operator change to get this new  $E_A$ , and to what new value.  
Hint: reread the initial problem statement.

i) Did the power angle change with the the previous change?  
If yes, say whether it increased or decreased. No calculation is required.

### Answers

1.  $\pm 15.8$  kVAR    2. a)  $38.68\text{-deg}$     b)  $918\text{-A}$  /  $19.34\text{-deg}$     c)  $-6.32\text{-MVAR}$   
 3. a)  $12.96\text{-MW}$     b)  $-3.459\text{-MVAR}$     c)  $3.437\cdot 10^4\text{-N}\cdot\text{m}$     d)  $7.604\text{-kV}$     e)  $18.35\text{-deg}$     f)  $9.197\text{-kV}$     g)  $15.1\text{-deg}$   
 4. a)  $0^\circ$     b)  $0\text{-W}$     c)  $30.38\text{-}\Omega$     d)  $24.94\text{-kVAR}$     e)  $188.5\text{-kW}$     f)  $24.68\text{-deg} - 16.1\text{-deg}$     g)  $2407\text{-V}$   
 h) The operator changes the field current to:  $21.9\text{-A}$     i) decreased

Name \_\_\_\_\_

a

1. 4.39 Refer to the per-phase phasor diagram at right.

It is for a 12-pole, three-phase synchronous machine.

a) Is the machine operating as a motor or a generator?

b) What is the voltage and apparent power into/out of the machine?

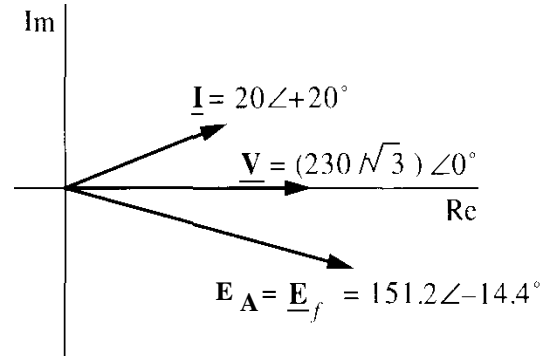

c) Determine the synchronous reactance of the machine.

d) For the same real power, what magnitude of excitation voltage yields unity power factor?

2. 4.41. A cylindrical-rotor, 60-Hz, Y-connected, three-phase, 12-pole synchronous motor operates from 2300 V and produces 500 hp. The motor operates with unity power factor with an excitation voltage of  $E_A = 1620$  V per phase. Neglect losses. Determine the following:

a) The current.

b) The synchronous reactance.

c) The torque.

d) The rotor power angle.

3. 4.43. The per-phase phasor diagram for a three-phase, 60-Hz, 8-pole synchronous motor is shown. Note that all sides and two angles of the triangle are shown. The current/phase is 21 A

a) Is the motor overexcited or underexcited?

e) Determine the output power and torque, neglecting mechanical losses.

b) What is the rotor power angle?

c) What is the power factor and is it leading or lagging?

d) Determine the synchronous reactance per phase.

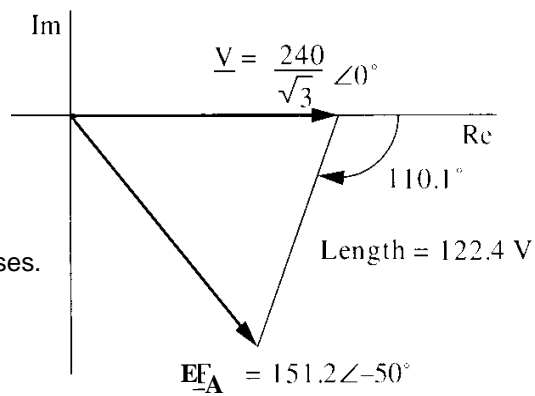

**Answers**

- |                    |            |                  |              |                           |
|--------------------|------------|------------------|--------------|---------------------------|
| 1. a) motor        | b) 132.8·V | 7.97·kVA         | c) 2·Ω       | d) E <sub>A</sub> = 138·V |
| 2. a) 93·6·A       | b) 9.92·Ω  | c) 5934·N·m      | d) 34.95·deg |                           |
| 3. a) underexcited | b) -50·deg | c) 0.939 lagging |              |                           |
| d) 5.83·Ω          | e) 11·hp   | 87·N·m           |              |                           |