

ECE 3600 3-Phase Power notes

Single phase power pulses at 120 Hz. This is not suitable for motors or generators over about 5 hp.

Two-phase power is constant as long as the two loads are balanced.

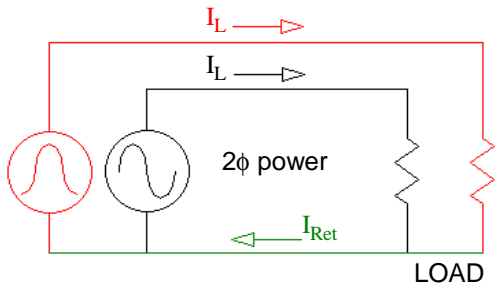

But, the return current is larger than either load current.

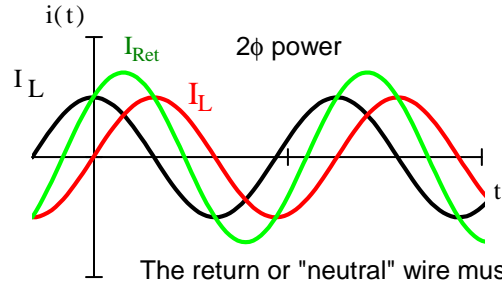

The return or "neutral" wire must be thicker than either "hot" line.

3-Phase Power

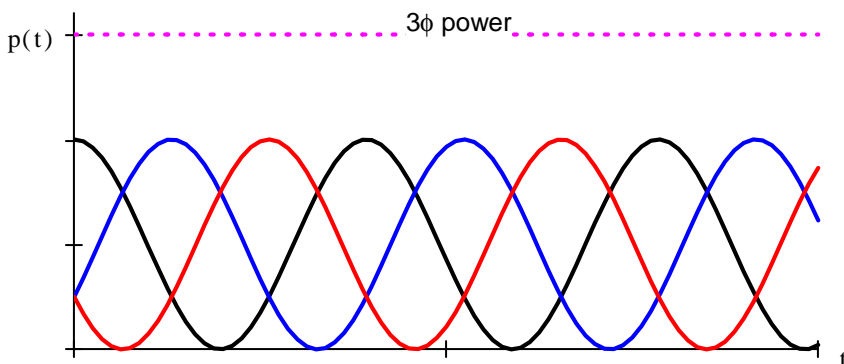
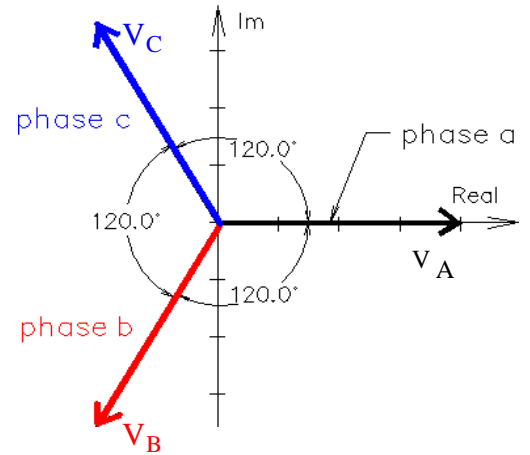
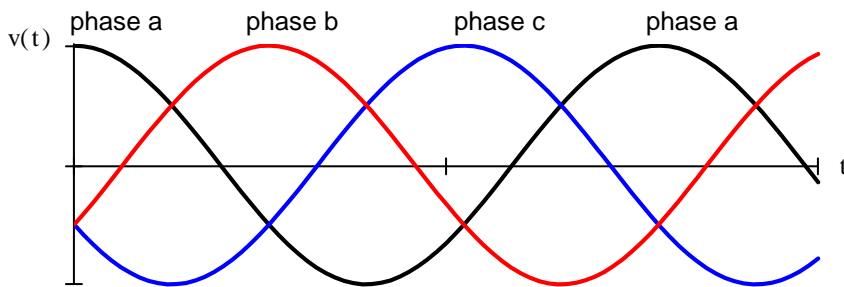
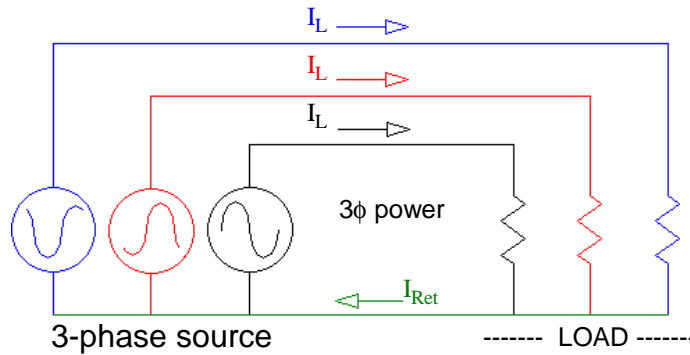

Three phase power is constant as long as the three loads are balanced.

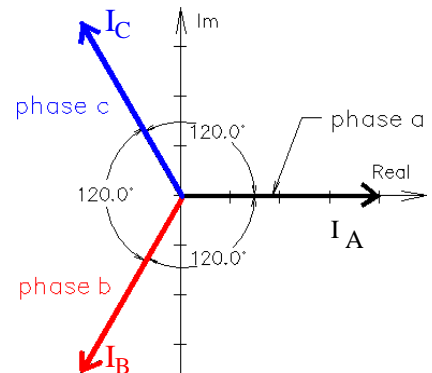
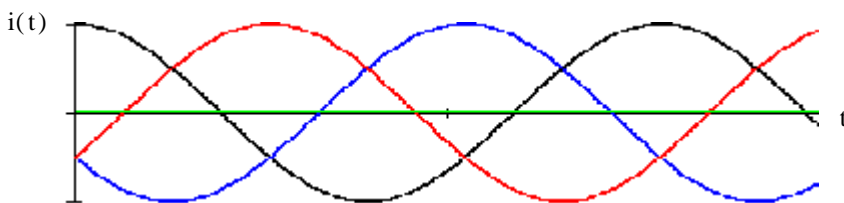

If loads are balanced, ground return current will be zero.

If the loads are close to balanced the relatively small return current can be carried by the earth ground.

Basics

Single phase power pulses at 120 Hz. This is not good for motors or generators over about 5 hp.

Three phase power is constant as long as the three loads are balanced.

Three lines are needed to transmit 3-phase power. If loads are balanced, ground return current will be zero.

The 3 lines coming into your house are **NOT** 3-phase. They are +120 V, Gnd, -120 V

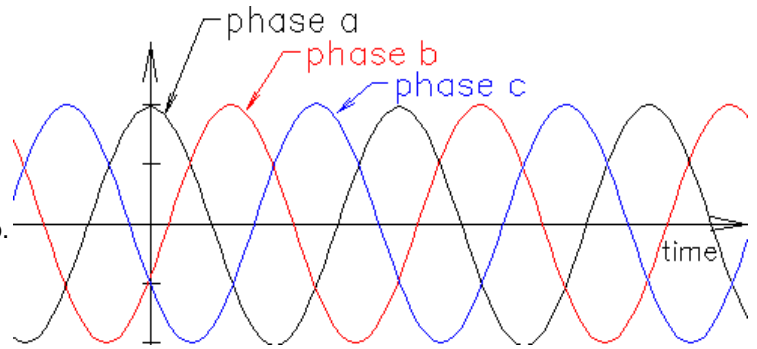

(The two 120s are 180° out-of-phase, allowing for 240 V connections)

3-phase outlets have 4 connections

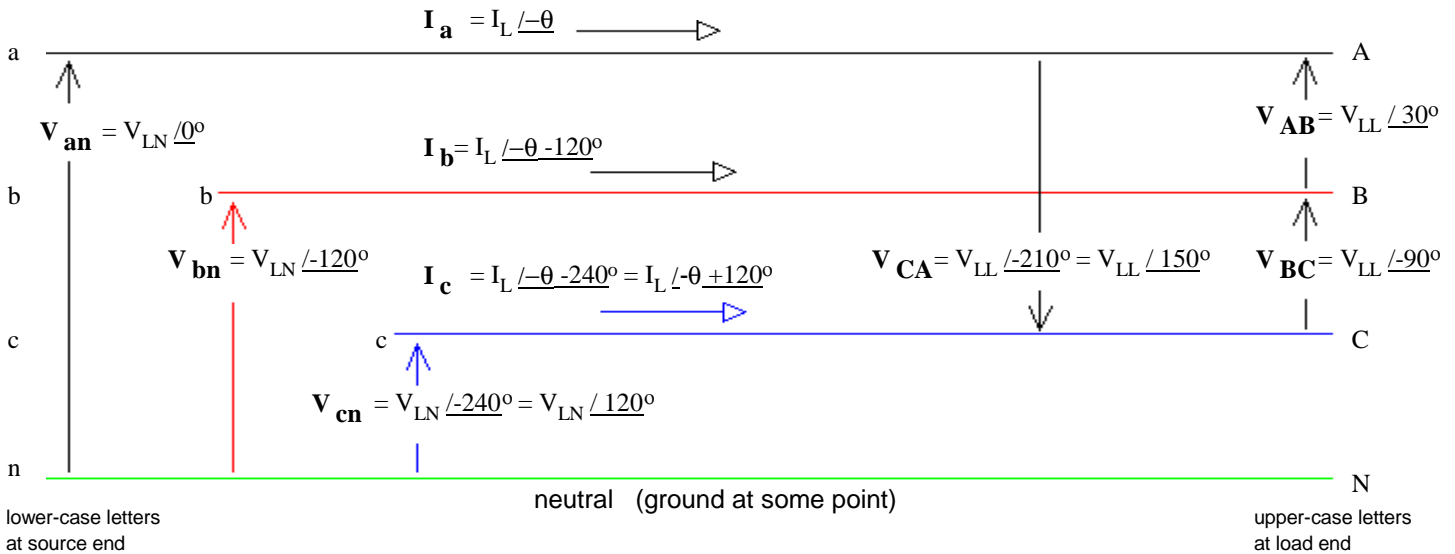

Connections to the 3 Lines

Wye connection:

Connect each load or generator phase between a line and ground.

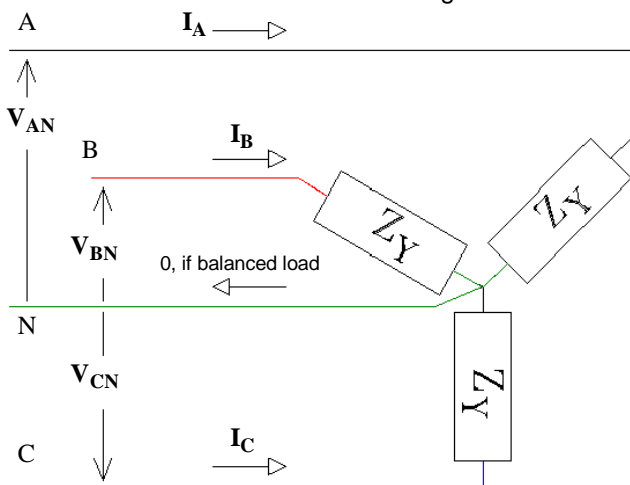

Delta connection:

Connect each load or generator phase between two lines.

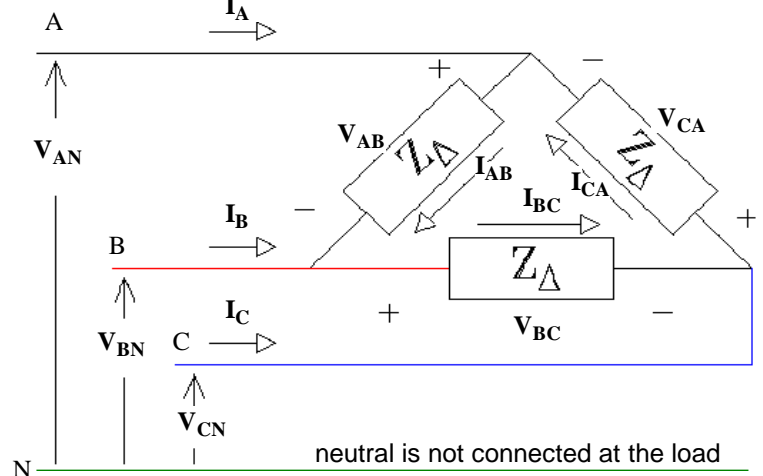

$$|V_{AN}| = |V_{BN}| = |V_{CN}| = V_{LN} = \frac{V_{LL}}{\sqrt{3}} = \frac{V_L}{\sqrt{3}}$$

$$|I_A| = |I_B| = |I_C| = I_L = \sqrt{3} \cdot I_{LL}$$

$$|V_{AB}| = |V_{BC}| = |V_{CA}| = V_{LL} = \sqrt{3} \cdot V_{LN} = V_L$$

$$|I_{AB}| = |I_{BC}| = |I_{CA}| = I_{LL} = \frac{I_L}{\sqrt{3}}$$

To get equivalent line currents with equivalent voltages: $Z_Y = \frac{Z_\Delta}{3}$ $Z_\Delta = 3 \cdot Z_Y$

Wye, Y, connection:

Connect each load or generator phase between a line and ground.

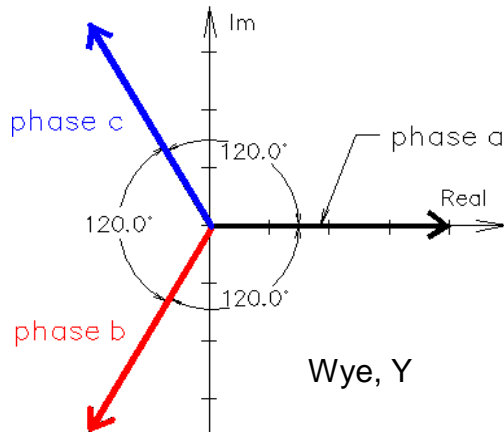

$$V_{LN} = \frac{V_{LL}}{\sqrt{3}} \quad I_L = \sqrt{3} \cdot I_{LL} \quad (\Delta\text{-connection})$$

Delta, Δ, connection:

Connect each load or generator phase between two lines.

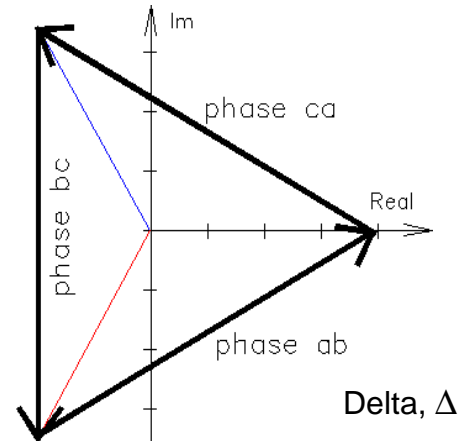

$$V_{LL} = \sqrt{3} \cdot V_{LN} \quad I_{LL} = \frac{I_L}{\sqrt{3}}$$

Apparent Power: $|S_{3\phi}| = 3 \cdot |S_{1\phi}| = 3 \cdot V_{LN} \cdot I_L = 3 \cdot V_{LL} \cdot I_{LL} = \sqrt{3} \cdot V_{LL} \cdot I_L$

Power: $P_{3\phi} = 3 \cdot P_{1\phi} = 3 \cdot V_{LN} \cdot I_L \cdot \text{pf} = 3 \cdot V_{LL} \cdot I_{LL} \cdot \text{pf} = \sqrt{3} \cdot V_{LL} \cdot I_L \cdot \text{pf} = S_{3\phi} \cdot \text{pf}$
 $\text{pf} = \cos(\theta)$

Reactive power: $Q_{3\phi} = 3 \cdot Q_{1\phi} = 3 \cdot V_{LN} \cdot I_L \cdot \sin(\theta) \text{ etc...} = \sqrt{(|S_{3\phi}|)^2 - P_{3\phi}^2}$

Cautions about "L" subscripts:

I_L is always the line current, same as would flow in a Y-connected device.

V_L is always the line-to-line voltage, same as across a Δ-connected device.

When a single phase is taken from a 3-phase panel, then the line voltage (V_L) of that single phase is the line-to-neutral voltage of the 3-phase input to that panel, so the value of V_L changes in the panel (isn't that nice?).

Z_L could be the load impedance, either Y-connected or Δ-connected, or it could be the line impedance--the impedance in the line itself, between the source and the load.

Cautions about "φ" or "ph" subscripts:

In our book: $V_\phi =$ the voltage across a single phase of a source or load and depends on the connection of that load, V_{LN} for Y-connected devices and V_{LL} for Δ-connected devices.

I_ϕ Also depends on connection.

In **some** books: $V_\phi = V_{ph} = V_{LN} \quad I_\phi = I_{ph} =$ current in a Y-connection <-- DON'T USE in this class

Phase sequences:

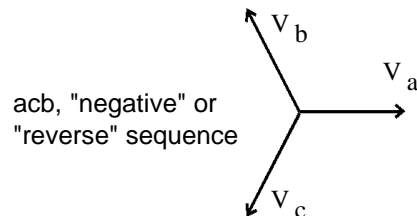
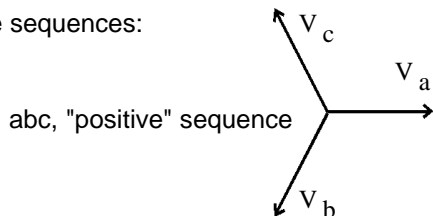

Common usage: $V_L = V_{LL}$ "line voltage" = line-to-line voltage

An unspecified voltage or a "line" voltage must always be assumed to be line-to-line,

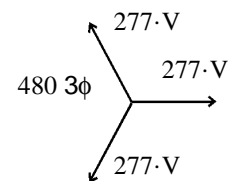
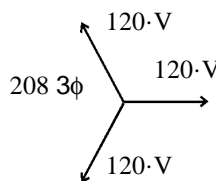

Our Approach Only works if system is **Balanced** (Always so in our class)

- 1) Change all Δ -connected loads to equivalent Y-connected loads $Z_Y = \frac{Z_\Delta}{3}$

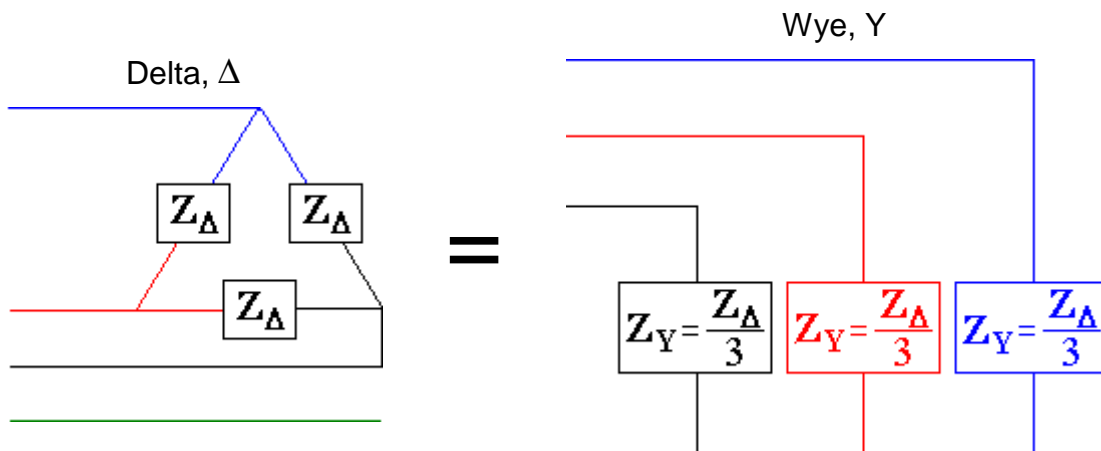

- 2) Find all voltages as V_{LN} , especially $V_{LN} = \frac{V_L}{\sqrt{3}}$
- 3) Change all power numbers to 1 ϕ .

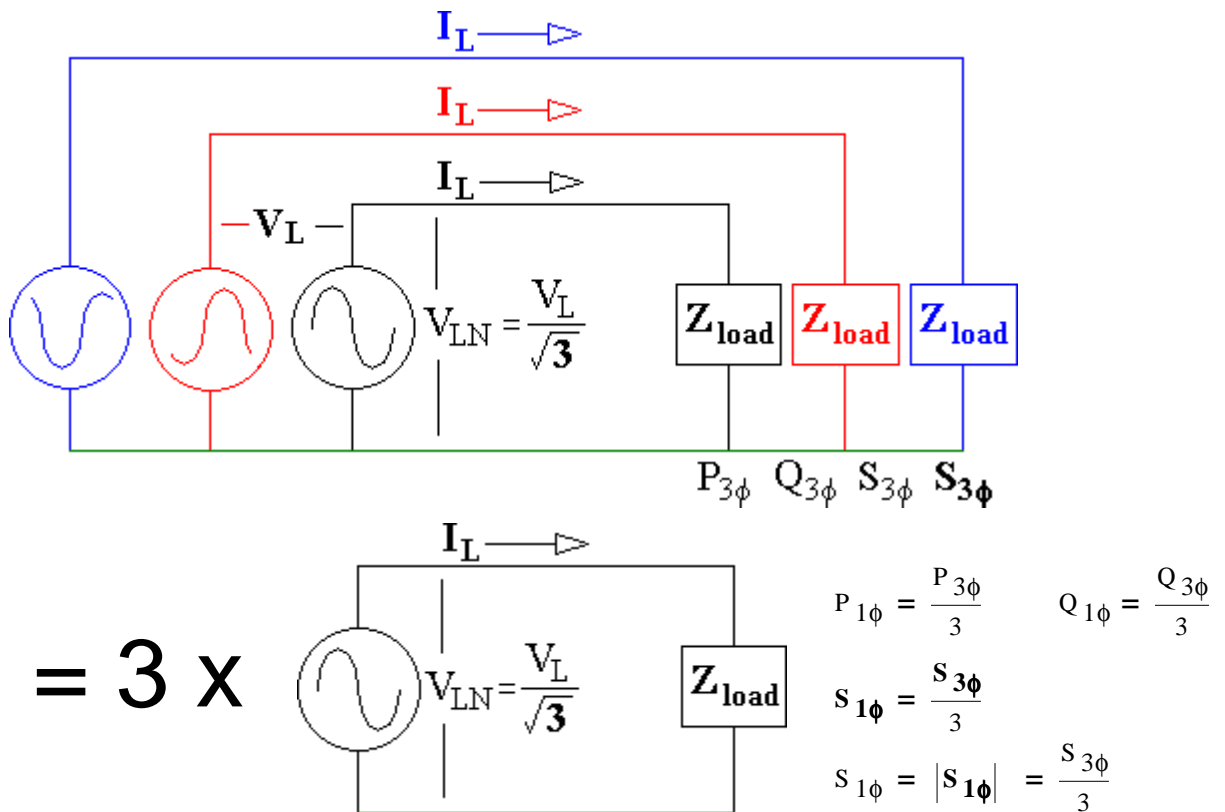

- 4) Solve the remaining single-phase problem.
- 5) Return to "line" voltages and 3 ϕ powers, as necessary.

$$V_L = \sqrt{3} \cdot V_{LN}$$

$$P_{3\phi} = 3 \cdot P_{1\phi}$$

$$Q_{3\phi} = 3 \cdot Q_{1\phi}$$

$$|S_{3\phi}| = 3 \cdot |S_{1\phi}|$$

$$S_{3\phi} = 3 \cdot S_{1\phi}$$

In rare cases, you may also need:

$$I_\Delta = I_{LL} = \frac{I_L}{\sqrt{3}}$$

and: $Z_\Delta = 3 \cdot Z_Y$

ECE 3600 3-Phase Examples

A. Stolp
9/9/09
rev 9/5/20

Ex. 1 A Y-connected load is connected to 208-V, 3-phase.
It draws 1.2kW of power at a power factor of 75%, leading.

$$P_{3\phi} := 1.2 \cdot \text{kW} \quad \text{pf} := 0.75$$

a) Find the apparent power and the reactive power.

$$S_{3\phi} := \frac{P_{3\phi}}{\text{pf}} \quad S_{3\phi} = 1.6 \cdot \text{kVA} \quad Q_{3\phi} := -\sqrt{S_{3\phi}^2 - P_{3\phi}^2} \quad Q_{3\phi} = -1.058 \cdot \text{kVAR}$$

Negative because the power factor is leading.

b) Find the line current.

Our Approach 1) Change all Δ -connected loads to equivalent Y-connected loads $Z_Y = \frac{Z_\Delta}{3}$ NOT NEEDED

2) Find all voltages as $V_{LN} := \frac{208 \cdot \text{V}}{\sqrt{3}} \quad V_{LN} = 120.089 \cdot \text{V}$

3) Change all power numbers to 1 ϕ . $P_{1\phi} := \frac{P_{3\phi}}{3} \quad P_{1\phi} = 400 \cdot \text{W}$
 $Q_{1\phi} := \frac{Q_{3\phi}}{3} \quad Q_{1\phi} = -352.767 \cdot \text{VAR}$
 $S_{1\phi} := \frac{S_{3\phi}}{3} \quad S_{1\phi} = 533.333 \cdot \text{VA}$

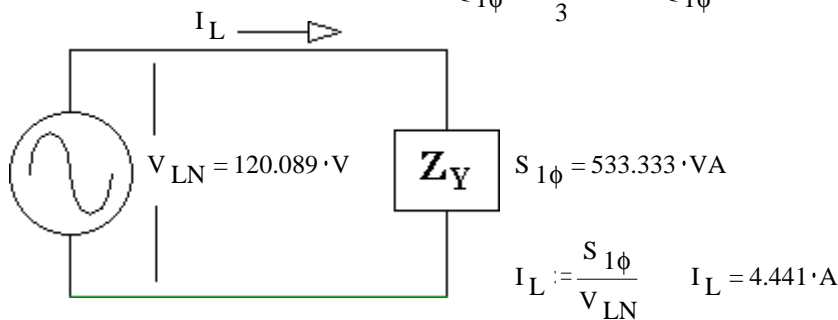

c) Find the values of the load components, assuming they are connected in series.

The components must be a resistor and a capacitor because there is some real power and the power factor is leading.

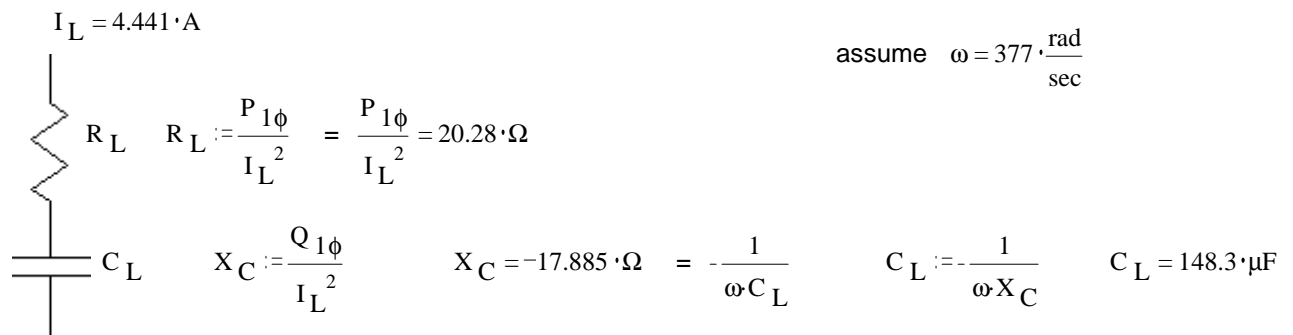

d) Find the values of the load components, assuming they are connected in parallel.

Still a resistor and a capacitor.

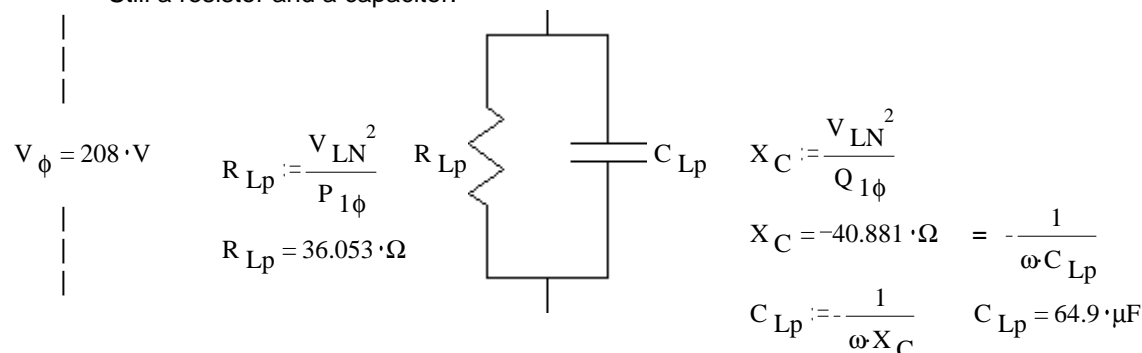

e) Correct the power factor with Y-connected components.
Need inductors

$$Q_{1\phi Ind} := -Q_{1\phi} = \frac{V_{\phi}^2}{\omega L_Y} \quad L_Y := \frac{V_{\phi}^2}{\omega \cdot Q_{1\phi}} \quad L_Y = 325.3 \cdot \text{mH}$$

f) Correct the power factor with Δ-connected components.

$$L_{\Delta} := \frac{(\sqrt{3} \cdot V_{\phi})^2}{\omega \cdot Q_{1\phi}} \quad L_{\Delta} = 975.9 \cdot \text{mH}$$

$$\text{OR } \omega L_{\Delta} = Z_{\Delta} = 3 \cdot Z_Y = 3 \cdot \omega L_Y \quad 3 \cdot L_Y = 975.9 \cdot \text{mH}$$

Ex. 2 From F08, exam 1, Find the following:

a) The line current that would be measured by an ammeter.

$$V_{LL} := 480 \cdot \text{V} \quad Z_{\Delta} := (30 + 12j) \cdot \Omega$$

Our Approach

1) Change all Δ-connected loads to equivalent Y-connected loads

$$Z_Y := \frac{Z_{\Delta}}{3} \quad Z_Y = 10 + 4j \cdot \Omega$$

2) Find all voltages as $V_{LN} \quad V_{LL} = 480 \cdot \text{V} \quad V_{LN} := \frac{V_{LL}}{\sqrt{3}}$

3) Change all power numbers to 1φ. NOT NEEDED

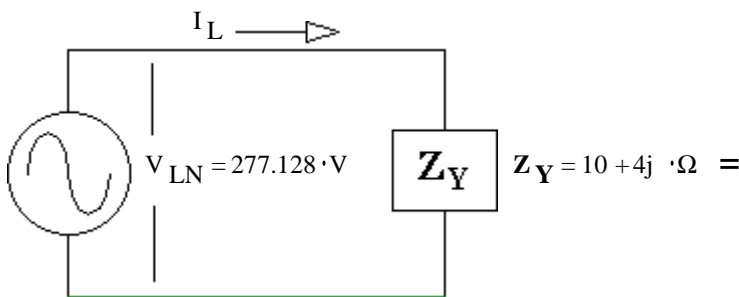

$$I_L := \frac{V_{LN}}{|Z_Y|} = \frac{277.128 \cdot \text{V}}{\sqrt{10^2 + 4^2} \cdot \Omega} = 25.731 \cdot \text{A}$$

b) The power consumed by the three-phase load.

c) The value of Y-connected impedances that would result in exactly the same line currents and same pf.

$$Z_Y = 10 + 4j \cdot \Omega$$

d) The value of Y-connected capacitors that would correct the pf.

$$Q_{1\phi} := \sqrt{S_{1\phi}^2 - P_{1\phi}^2} \quad Q_{1\phi} := \sqrt{(V_{LN} \cdot I_L)^2 - (6.62 \cdot \text{kW})^2} \quad Q_{1\phi} = 2.65 \cdot \text{kVAR}$$

so we need:

$$Q_C := -Q_{1\phi} \quad Q_C = -2.65 \cdot \text{kVAR} = -\frac{V_{LN}^2}{\left(\frac{1}{\omega C}\right)} = -V_{LN}^2 \cdot \omega C \quad C := \frac{Q_C}{-V_{LN}^2 \cdot \omega} \quad C = 91.5 \cdot \mu\text{F}$$

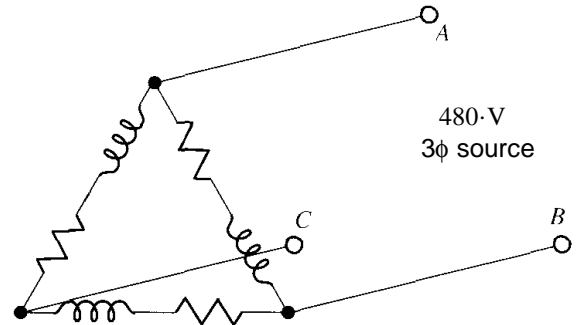

$$\text{All } Z := (30 + 12j) \cdot \Omega$$

$$V_{LN} = 277.128 \cdot \text{V}$$

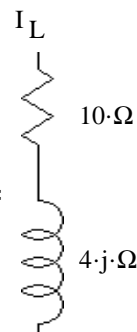

$$I_L = 25.731 \cdot \text{A}$$

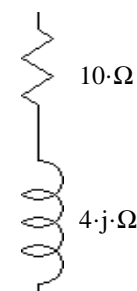

$$P_{1\phi} = I_L^2 \cdot 10 \cdot \Omega = 6.62 \cdot \text{kW}$$

$$P_{3\phi} = 3 \cdot (I_L^2 \cdot 10 \cdot \Omega) = 19.86 \cdot \text{kW}$$

ECE 3600 3-Phase Examples p3

Ex. 3 For the three-phase delta-connected load in fig P1.7, The line-to-line voltage and line current are:

$$\underline{V}_{AB} := 480\text{V} \angle 0^\circ \quad \underline{I}_A = 10\text{A} \angle -40^\circ$$

a) What is \underline{V}_{CA} ?

Normal phase angles

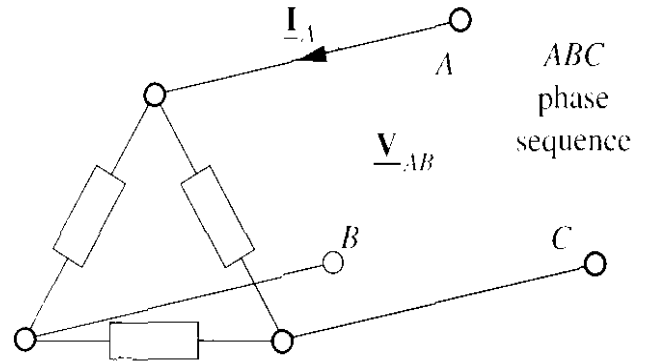
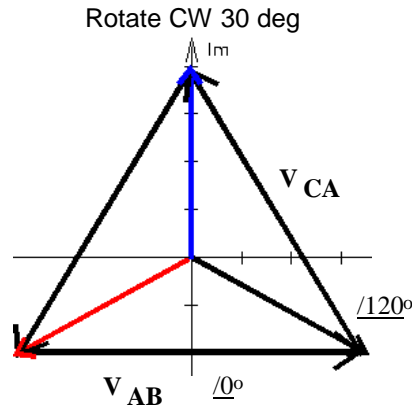
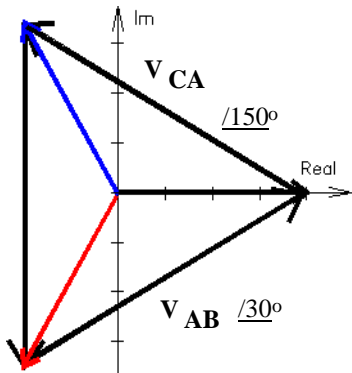

Figure P1.7

$$\begin{aligned} \underline{V}_{CA} &:= 480\text{V} \angle 120^\circ \\ &= 480\text{V} \angle -240^\circ \end{aligned}$$

b) What is the phase current in the load?

$$I_{LL} = \frac{I_L}{\sqrt{3}} = \frac{10\text{A}}{\sqrt{3}} = 5.774\text{A}$$

c) What is the time-average power into the load?

$$\underline{V}_{AN} := \frac{480\text{V}}{\sqrt{3}} \angle -30^\circ \quad \text{Since } \underline{I}_A = 10\text{A} \angle -40^\circ \quad \text{I lags V by } 10^\circ$$

$\theta := 10\text{-deg}$

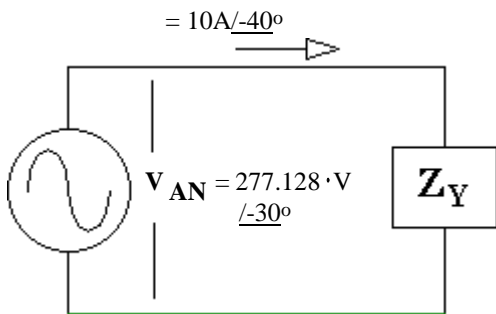
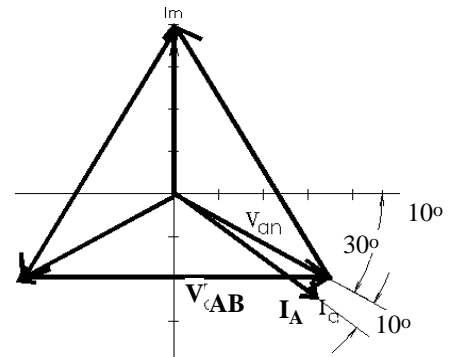

$$P_{1\phi} = (277.128\text{V} \cdot 10\text{A}) \cdot \cos(\theta) = 2.729\text{kW}$$

$$P_{3\phi} = 3 \cdot (277.128\text{V} \cdot 10\text{A}) \cdot \cos(\theta) = 8.188\text{kW}$$

d) What is the phase impedance?

$$\underline{Z}_Y := \frac{277.128\text{V}}{10\text{A}} \angle_{-30 - (-40)}^\circ \quad \underline{Z}_Y = 27.71\Omega \angle 10^\circ$$

$$\underline{Z}_\Delta = 3 \cdot \underline{Z}_Y = 83.14\Omega \angle 10^\circ$$

Ex. 4 In the three-phase circuit shown in Fig. P1.9. find the following:

a) The line current that would be measured by an ammeter.

Direct way

$$V_{LL} := 600 \cdot \text{V} \quad Z_{\Delta} := (20 + 11j) \cdot \Omega$$

$$I_{AB} := \left| \frac{V_{LL}}{Z_{\Delta}} \right| \quad I_{AB} = 26.286 \cdot \text{A}$$

$$I_A := \sqrt{3} \cdot I_{AB} \quad I_A = 45.53 \cdot \text{A}$$

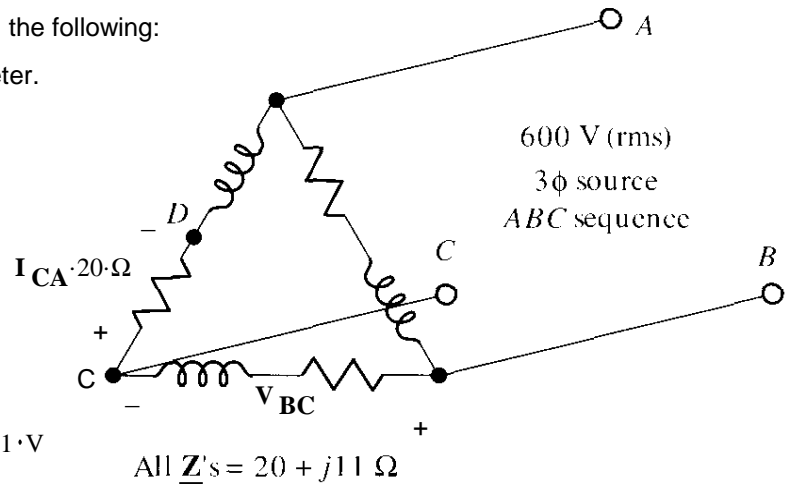
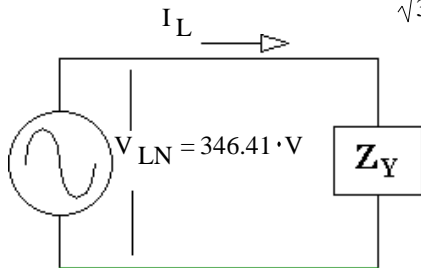

Figure P1.9

Our Approach

$$V_{LN} := \frac{600 \cdot \text{V}}{\sqrt{3}} \quad V_{LN} = 346.41 \cdot \text{V}$$



$$Z_Y := \frac{Z_{\Delta}}{3} \quad Z_Y = 6.667 + 3.667j \cdot \Omega$$

$$I_L := \frac{V_{LN}}{|Z_Y|} = \frac{346.41 \cdot \text{V}}{\sqrt{6.667^2 + 3.667^2}} \quad I_L = 45.53 \cdot \text{A}$$

b) The power factor of the three-phase load.

$$\theta := \text{atan}\left(\frac{11}{20}\right) \quad \theta = 28.811 \cdot \text{deg} \quad \text{pf} \cos(\theta) = 0.876$$

c) The voltage that would be measured between B and D by a voltmeter.

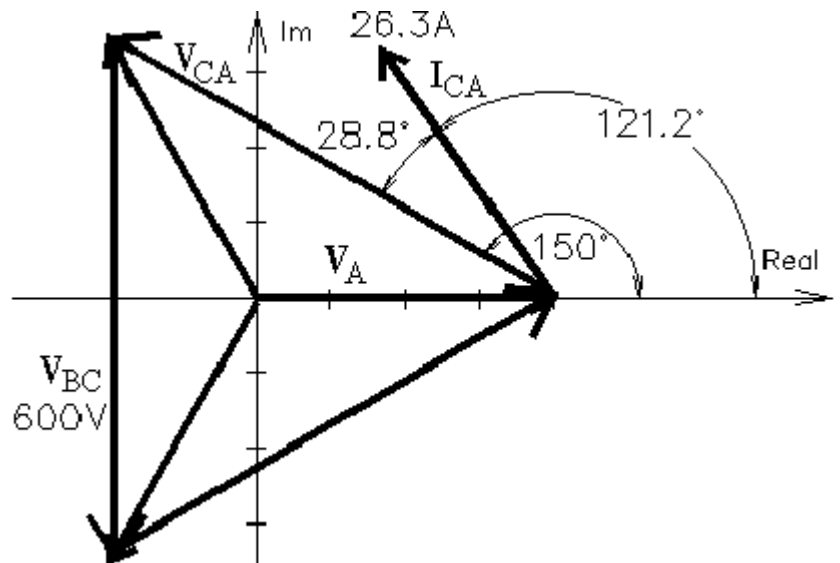
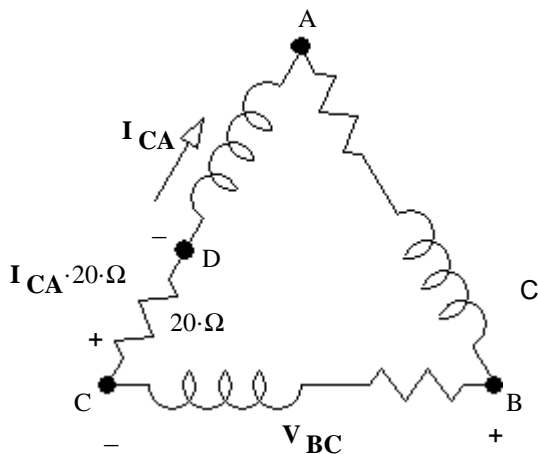

Using V_A as reference (0°):

$$V_{BC} := 600 \cdot \text{V} \cdot e^{-j \cdot 90 \cdot \text{deg}}$$

$$I_{CA} := 26.286 \cdot \text{A} \cdot e^{j \cdot (150 - 28.811) \cdot \text{deg}}$$

$$V_{CD} := I_{CA} \cdot 20 \cdot \Omega$$

$$V_{CD} = -272.251 + 449.734j \cdot \text{V}$$

$$V_{BD} := V_{BC} + V_{CD} \quad V_{BD} = -272.251 - 150.266j \cdot \text{V} \quad |V_{BD}| = 311 \cdot \text{V}$$

(must be the sum, NOT the difference, see the + and - signs on the drawing.)

Ex. 5 When all you have is impedances and an input voltage, it gets messy & luckily, it's not a common problem.

Textbook problem 2-2. Figure P2-1 shows a three-phase power system with two loads. The Δ -connected generator is producing a line voltage of 480 V, and the line impedance is $0.09 + j0.16 \Omega$. Load 1 is Y-connected, with a phase impedance of $2.5 \Omega \angle 36.87^\circ$ and load 2 is Δ -connected, with a phase impedance of $5 \Omega \angle -20^\circ$.

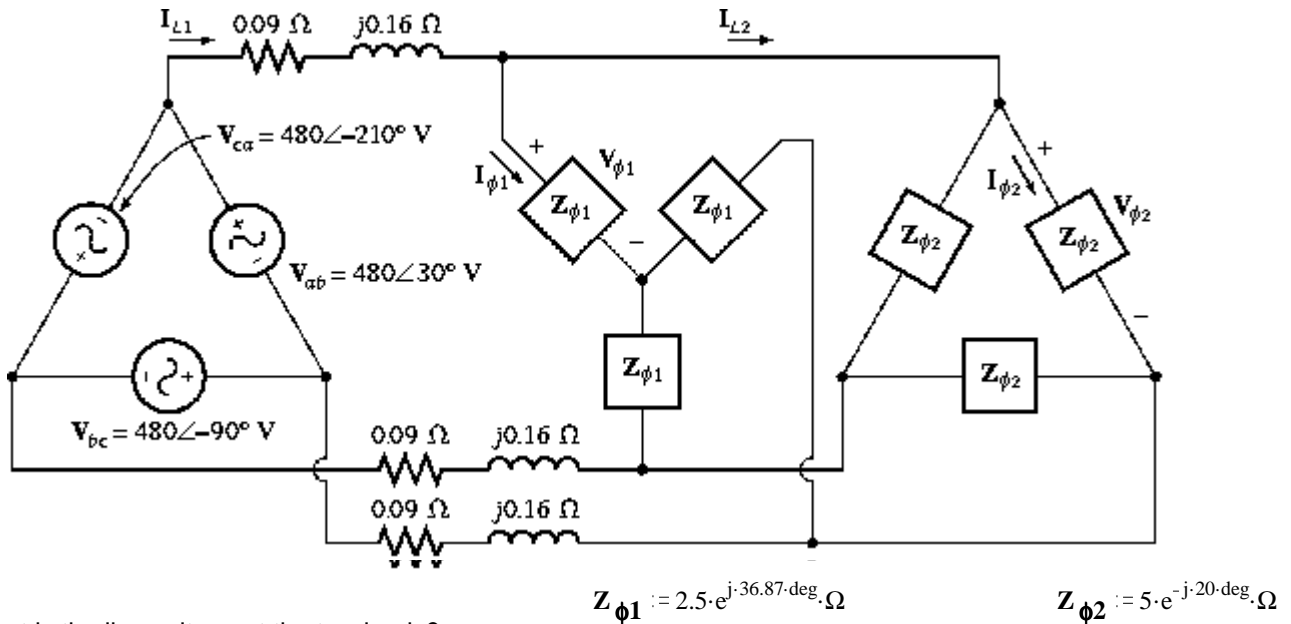

a) What is the line voltage at the two loads?

Find an equivalent Y-only circuit: $Z_{\text{line}} := (0.09 + 0.16 \cdot j) \cdot \Omega$

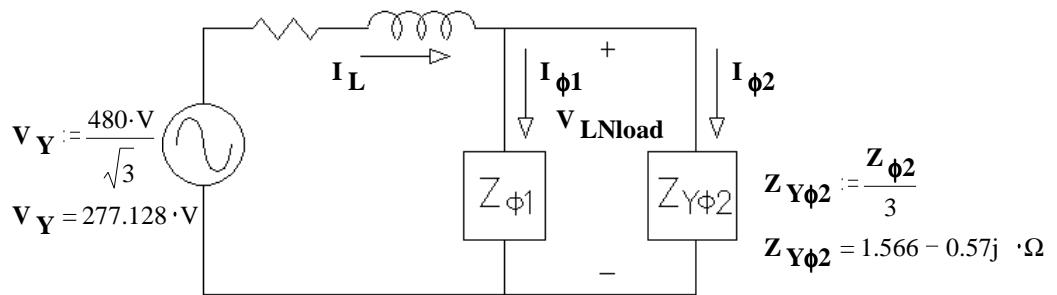

$$Z_{Y\text{loads}} := \frac{1}{\frac{1}{Z_{\phi 1}} + \frac{1}{Z_{Y\phi 2}}} \quad Z_{Y\text{loads}} = 1.13 + 0.044j \cdot \Omega \quad |Z_{Y\text{loads}}| = 1.131 \cdot \Omega$$

$$\arg(Z_{Y\text{loads}}) = 2.254 \cdot \text{deg}$$

$$Z_{Y\text{tot}} := Z_{\text{line}} + Z_{Y\text{loads}} \quad Z_{Y\text{tot}} = 1.22 + 0.204j \cdot \Omega \quad |Z_{Y\text{tot}}| = 1.237 \cdot \Omega$$

$$\arg(Z_{Y\text{tot}}) = 9.516 \cdot \text{deg}$$

$$I_L := \frac{V_Y}{Z_{Y\text{tot}}} \quad I_L = 220.998 - 37.047j \cdot \text{A} \quad |I_L| = 224.082 \cdot \text{A}$$

$$\arg(I_L) = -9.516 \cdot \text{deg}$$

$$V_{LN\text{load}} := I_L \cdot Z_{Y\text{loads}} \quad V_{LN\text{load}} = 251.311 - 32.025j \cdot \text{V} \quad |V_{LN\text{load}}| = 253.343 \cdot \text{V}$$

$$\arg(V_{LN\text{load}}) = -7.262 \cdot \text{deg}$$

$$V_{L\text{load}} := V_{LN\text{load}} \cdot \sqrt{3} \quad V_{L\text{load}} = 435.283 - 55.47j \cdot \text{V} \quad |V_{L\text{load}}| = 438.803 \cdot \text{V}$$

b) What is the voltage drop on the transmission lines?

$$\mathbf{V}_{\text{linedrop}} := \mathbf{I}_L \cdot \mathbf{Z}_{\text{line}} \quad \mathbf{V}_{\text{linedrop}} = 25.817 + 32.025j \cdot \text{V} \quad |\mathbf{V}_{\text{linedrop}}| = 41.136 \cdot \text{V}$$

$$\arg(\mathbf{V}_{\text{linedrop}}) = 51.126 \cdot \text{deg}$$

Check: $\mathbf{V}_Y - \mathbf{V}_{L\text{load}} = 25.817 + 32.025j \cdot \text{V}$

c) Find the real and reactive powers supplied to each load.

$$I_{\phi 1} := \frac{|\mathbf{V}_{L\text{load}}|}{|\mathbf{Z}_{\phi 1}|} \quad I_{\phi 1} = 101.337 \cdot \text{A} \quad I_{\phi 2} := \frac{|\mathbf{V}_{L\text{load}}|}{|\mathbf{Z}_{Y\phi 2}|} \quad I_{\phi 2} = 152.006 \cdot \text{A}$$

$$P_{3\phi 1} := 3 \cdot I_{\phi 1}^2 \cdot \text{Re}(\mathbf{Z}_{\phi 1}) \quad P_{3\phi 1} = 61.615 \cdot \text{kW} \quad P_{3\phi 2} := 3 \cdot I_{\phi 2}^2 \cdot \text{Re}(\mathbf{Z}_{Y\phi 2}) \quad P_{3\phi 2} = 108.562 \cdot \text{kW}$$

$$Q_{3\phi 1} := 3 \cdot I_{\phi 1}^2 \cdot \text{Im}(\mathbf{Z}_{\phi 1}) \quad Q_{3\phi 1} = 46.212 \cdot \text{kVAR} \quad Q_{3\phi 2} := 3 \cdot I_{\phi 2}^2 \cdot \text{Im}(\mathbf{Z}_{Y\phi 2}) \quad Q_{3\phi 2} = -39.513 \cdot \text{kVAR}$$

d) Find the real and reactive power losses in the transmission line.

$$P_{3\phi L} := 3 \cdot (|\mathbf{I}_L|)^2 \cdot \text{Re}(\mathbf{Z}_{\text{line}}) \quad P_{3\phi L} = 13.557 \cdot \text{kW}$$

$$Q_{3\phi L} := 3 \cdot (|\mathbf{I}_L|)^2 \cdot \text{Im}(\mathbf{Z}_{\text{line}}) \quad Q_{3\phi L} = 24.102 \cdot \text{kVAR}$$

e) Find the real power, reactive power, and power factor supplied by the generator.

$$P_{3\phi \text{gen}} := P_{3\phi L} + P_{3\phi 1} + P_{3\phi 2} \quad P_{3\phi \text{gen}} = 183.734 \cdot \text{kW}$$

$$Q_{3\phi \text{gen}} := Q_{3\phi L} + Q_{3\phi 1} + Q_{3\phi 2} \quad Q_{3\phi \text{gen}} = 30.801 \cdot \text{kVAR} \quad \text{pf} = \frac{P_{3\phi \text{gen}}}{3 \cdot |\mathbf{V}_Y| \cdot |\mathbf{I}_L|} = 0.986 \text{ lagging}$$

f) What is the efficiency of this system?

$$\eta = \frac{P_{3\phi 1} + P_{3\phi 2}}{P_{3\phi \text{gen}}} = 92.621 \cdot \%$$

The next example uses a "one-line diagram" to show how a generator is connected to 3 loads. In these diagrams, one line represents all 3 phases and neutral. Because the individual lines are not shown, there may be notes or symbols to indicate Y or Δ connections. All powers given will be 3-phase values, all voltages will be line voltages (that is line-to-line) and all currents will be line currents. The term "bus" refers common connection area.

Ex. 6 The one-line diagram below shows a single, Y-connected generator and 3 loads. Assume all lines are lossless.

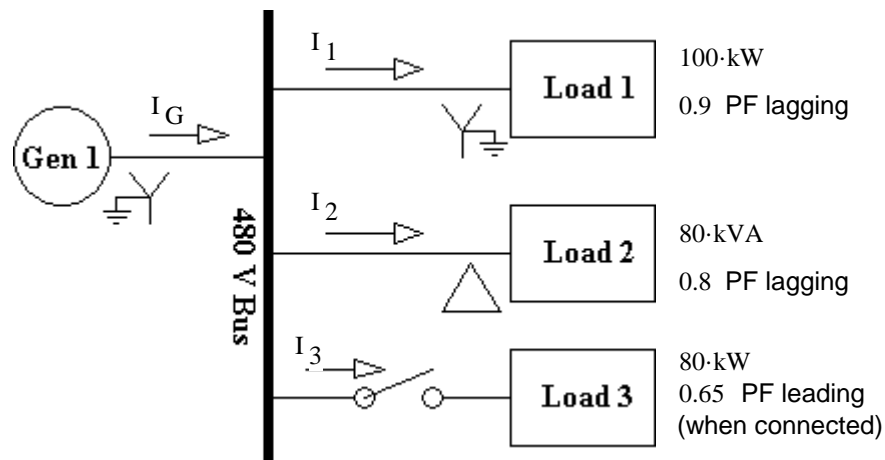

Find:

a) The phase voltage and currents in Load 1.

$$V_{LL} := 480 \cdot V \quad V_{LN} := \frac{V_{LL}}{\sqrt{3}} \quad V_{LN} = 277.128 \cdot V = V_{L1\phi}$$

$$pf_{L1} := 0.9 \quad S_{L1.1\phi} := \frac{100 \cdot kW}{3 \cdot pf_{L1}} \quad I_1 := \frac{S_{L1.1\phi}}{V_{LN}} \quad I_1 = 133.646 \cdot A = I_{L1\phi}$$

b) The phase voltage and currents in Load 2.

$$V_{LL} := 480 \cdot V = V_{L2\phi} \quad pf_{L2} := 0.8 \quad S_{L2.1\phi} := \frac{80 \cdot kVA}{3}$$

$$I_2 := \frac{S_{L2.1\phi}}{V_{LN}} \quad I_2 = 96.225 \cdot A = \sqrt{3} \cdot I_{L2\phi} \quad I_{L2\phi} = \frac{I_2}{\sqrt{3}} = 55.556 \cdot A$$

c) The real, reactive and apparent power supplied by the generator with the switch to load 3 open.

$$P_1 := 100 \cdot kW \quad P_2 := 80 \cdot kVA \cdot pf_{L2} \quad P_2 = 64 \cdot kW \quad P_G := P_1 + P_2 \quad P_G = 164 \cdot kW$$

$$Q_1 := \sqrt{\left(\frac{100 \cdot kW}{pf_{L1}}\right)^2 - (100 \cdot kW)^2} \quad Q_1 = 48.432 \cdot kVAR \quad Q_2 := \sqrt{(80 \cdot kVA)^2 - (64 \cdot kW)^2} \quad Q_2 = 48.432 \cdot kVAR$$

$$Q_G := Q_1 + Q_2 \quad Q_G = 96.432 \cdot kVAR$$

$$S_G := \sqrt{P_G^2 + Q_G^2} \quad S_G = 190.25 \cdot kVAR$$

d) The total line current from the generator, I_G , with the switch to load 3 open.

$$I_G = \frac{\left(\frac{S_G}{3}\right)}{V_{LN}} = 228.836 \cdot A$$

e) The real, reactive and apparent power supplied by the generator with the switch to load 3 closed.

$$pf_{L3} := 0.65 \quad S_{L3.1\phi} := \frac{80 \cdot kW}{3 \cdot pf_{L3}} \quad Q_3 := -\sqrt{\left(\frac{80 \cdot kW}{pf_{L3}}\right)^2 - (80 \cdot kW)^2} \quad Q_3 = -93.53 \cdot kVAR$$

$$P_G := P_1 + P_2 + 80 \cdot kW \quad P_G = 244 \cdot kW \quad Q_G := Q_1 + Q_2 + Q_3 \quad Q_G = 2.902 \cdot kVAR$$

$$S_G := \sqrt{P_G^2 + Q_G^2} \quad S_G = 244.017 \cdot kVAR$$

f) How does the total line apparent power from the generator, S_G , compare to the sum of the three individual apparent powers, $S_1 + S_2 + S_3$? If they aren't equal, why not? (Switch closed)

$$3 \cdot S_{L1.1\phi} + 80 \cdot kVAR + 3 \cdot S_{L3.1\phi} = 314.188 \cdot kVAR \neq S_G = 244.017 \cdot kVAR$$

Can't Add Magnitudes

g) The total line current from the generator, I_G , with the switch to load 3 closed.

$$I_G := \frac{\left(\frac{S_G}{3}\right)}{V_{LN}} \quad I_G = 293.507 \cdot A$$

h) How does the total line current from the generator, I_G , compare to the sum of the three individual currents, $I_1 + I_2 + I_3$? If they aren't equal, why not? (Switch closed)

$$I_3 := \frac{S_{L3.1\phi}}{V_{LN}} \quad I_3 = 148.039 \cdot A$$

$$I_1 + I_2 + I_3 = 377.909 \cdot A \neq I_G = 293.507 \cdot A$$

Can't Add Magnitudes

Note: All voltages and currents are always assumed to be RMS unless said to be otherwise.

- The following are questions from p 78 of the textbook. These could be good closed-book exam questions.
 - 2.1. What types of connections are possible for three-phase generators and loads?
 - 2.2. What is meant by the term “balanced” in a balanced three-phase system?
 - 2.3. What is the relationship between phase and line voltages and currents for a wye (Y) connection?
 - 2.4. What is the relationship between phase and line voltages and currents for a delta (Δ) connection?
 - 2.5. What is phase sequence?
 - 2.7. What is a Y- Δ transform?
- Textbook 2-1. Three impedances of $4 + j3 \Omega$ are Δ -connected and tied to a three-phase 208-V power line. Find I_ϕ , I_L , P, Q, S (|S|), and the power factor of this load.
- A balanced three-phase 480-V source (three line-to-neutral voltages of 277 V) supplies a balanced three-phase inductive load. The load draws a total of 9 kW at a power factor of 0.9. Calculate the phase currents and the magnitude of the per-phase load impedances, assuming a Y-connected load. Draw a phasor diagram showing all three voltages and currents, assume V_a is 0° .
 - In order to correct the power factor, three capacitors are connected in parallel with the load impedances. Find the value of the capacitors.
- Repeat problem 3, assuming a delta-connected load.
- The voltmeter shown measures 120 V. Let this voltage be the phase reference (0°). The phase impedance is $Z_\phi = 5.2 + j2.7 = 5.86 \angle 27.44^\circ \Omega$?
 - What is V_{AB} as a phasor?
 - What would the ammeter measure?
 - What is the apparent power?
 - What is the real power?
 - Correct the power factor with capacitors connected in a delta configuration, that is, find the value of the capacitors.
- Three 230-V generators are connected in a wye configuration to generate three-phase power. The load consists of three balanced delta-connected impedances of $Z_L = 3.8 + j1.5 \Omega$.
 - An ammeter is placed in one line, what would it measure?
 - Find the total apparent power.
 - Find the total real power consumed by the load.
 - What is the phase angle between I_A and V_{AB} , assuming ABC rotation?

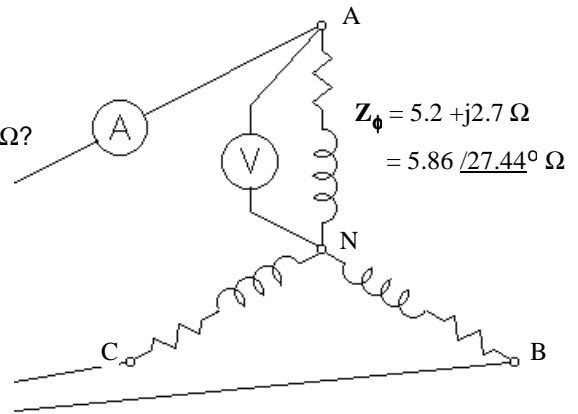

Answers

1. a) 2.1. Y & Δ b) 2.2. The 3 voltages are equal, the 3 currents are equal and the 3 loads are equal.

c) 2.3. $V_\phi = \frac{V_{LL}}{\sqrt{3}} = \frac{V_L}{\sqrt{3}}$ $I_\phi = I_L$ d) 2.4. $V_\phi = V_{LL} = V_L$ $I_\phi = \frac{I_L}{\sqrt{3}}$

e) 2.5. abc or acb f) 2.7. $Z_Y = \frac{Z_\Delta}{3}$ 2. 41.6A·A 72.1·A 20.8·kW
 15.6·kVAR 26.0·kVA

3. 12·A lagging by 25.8° 23· Ω
 b) 50.2· μ F

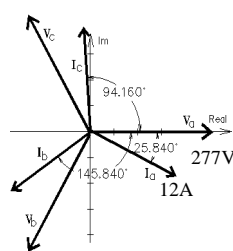

4. 6.95A / 4.16° 69.1· Ω
 b) 16.7· μ F

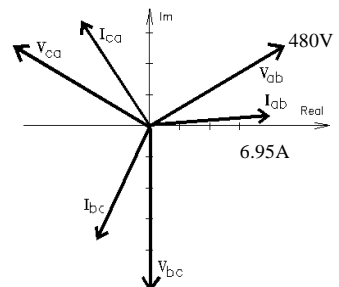

5. a) $208 \cdot V \cdot e^{j30 \cdot \text{deg}}$ b) 20.5·A c) 7.37·kVA d) 6.54·kW e) 69.5· μ F

6. 168·A 117·kVA 108·kW -51.541 $^\circ$

ECE 3600 homework # 5

Due: Wed, 9/14/22

c

1. A 3-phase circuit is connected as shown.
Find the following:

- The load power factor, assume lagging.
- The line current.
- The phase impedance, Z_ϕ
- The value of Y-connected impedances that would result in exactly the same line currents and same pf.
- The reactive power of each Z_ϕ
- Correct the power factor with capacitors connected in a wye configuration.

$$\omega := 377 \frac{\text{rad}}{\text{sec}}$$

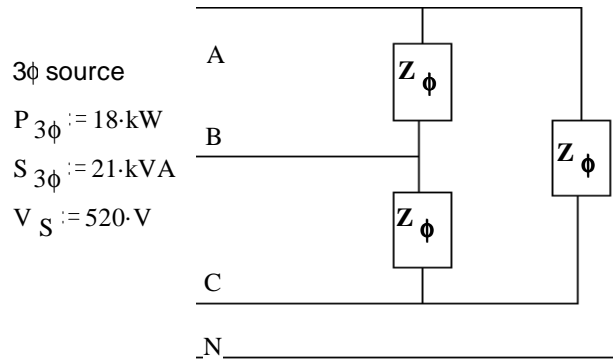

2. For the three-phase circuit shown, the R_{line} resistors represent the resistance of the distribution system. Find the following:

- Total power out of the source, including line and load.
- Line losses.
- Distribution system efficiency.

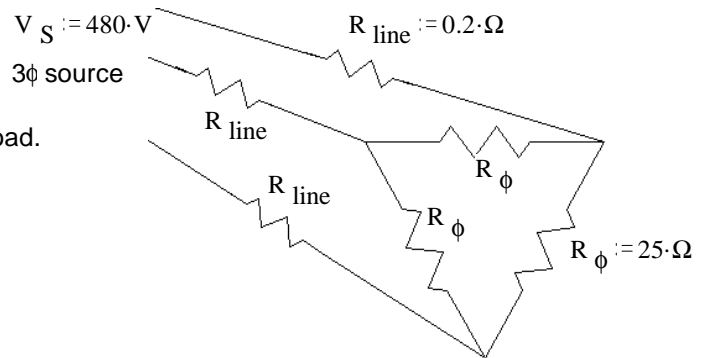

3. Textbook 2-6, modified

The figure below shows a one-line diagram of a small 480-V distribution system in an industrial plant. For parts a) and b), assume all the lines have zero impedance.

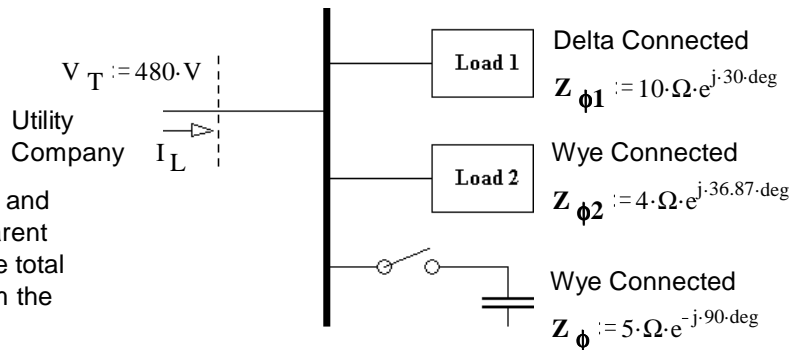

- With the switch open, find all the real, reactive and apparent powers in the system. (For the apparent power, just the total will be sufficient.) Find the total current supplied to the distribution system from the utility company (I_L).
- Repeat a) with the switch closed.
- What happened to the total current supplied by the utility when the switch closed? Why?

For the two parts below, assume the source voltage is adjusted so that the bus voltage at the plant remains 480V and the lines from the utility each have an impedance of Z_{line} .

- With the switch open, find the magnitude of the source voltage and the efficiency of the system.
- With the switch closed, find the magnitude of the source voltage and the efficiency of the system.

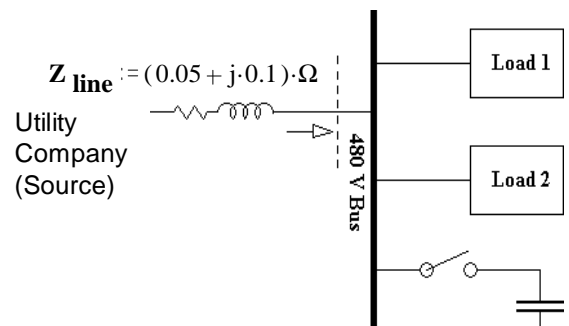

Answers

	2. a) 27-kW	3. a) 59.86-kW	b) Loads 1 & 2	c) Current is less by more
1. a) 0.857	b) 632.8-W	34.56-kVAR	are the same	than 20A because caps
b) 23.3-A	c) 97.7%	46.04-kW	Caps	supply most of the VARs
c) 38.6-Ω ∠ 31-deg		34.53-kVAR	0-W -46.06-kVAR	to loads 1 & 2.
d) 12.9-Ω ∠ 31-deg		input:	input:	d) 505.4-V 96.8%
e) 3.61-kVAR		105.9-kW	105.9-kW	e) 496.0-V 97.6%
f) 106-μF		69.09-kVAR	23.03-kVAR	
		126.4-kVA	108.4-kVA	
		152-A	130.4-A	