

Ex. 1 R & L together are the load. Find the real power P, the reactive power Q, the complex power S, the apparent power |S|, & the power factor pf. Draw phasor diagram for the power.

$V_{in} := 110 \cdot V$
 $\omega := 377 \cdot \frac{\text{rad}}{\text{sec}}$

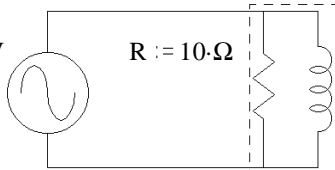

$R := 10 \cdot \Omega$ $L := 25 \cdot \text{mH}$

$Z := \frac{1}{\left(\frac{1}{R} + \frac{1}{j \cdot \omega \cdot L}\right)} = \frac{1}{0.1458 \cdot \frac{1}{\Omega} \cdot e^{-j \cdot 46.7 \cdot \text{deg}}}$

$Z = 4.704 + 4.991j \cdot \Omega$ $|Z| = 6.859 \cdot \Omega$ $\theta := \arg(Z)$ $\theta = 46.7 \cdot \text{deg}$ $\text{pf} := \cos(\theta)$ $\text{pf} = 0.686$

$I := \frac{V_{in}}{Z}$ $I = 11 - 11.671j \cdot A$ $|I| = 16.038 \cdot A$ $\arg(I) = -46.7 \cdot \text{deg}$

$P := |V_{in}| \cdot |I| \cdot \text{pf}$ $P = 1.21 \cdot \text{kW}$

$Q := |V_{in}| \cdot |I| \cdot \sin(\theta)$ $Q = 1.284 \cdot \text{kVAR}$ OR... $Q := |V_{in}| \cdot |I| \cdot \sqrt{1 - \text{pf}^2}$ $Q = 1.284 \cdot \text{kVAR}$

$S := V_{in} \cdot \bar{I}$ OR.. $S := P + j \cdot Q$ $S = 1.21 + 1.284j \cdot \text{kVA}$ $S := \sqrt{\text{Re}(S)^2 + \text{Im}(S)^2} = |S| = 1.764 \cdot \text{kVA}$
 $\text{atan}\left(\frac{\text{Im}(S)}{\text{Re}(S)}\right) = 46.696 \cdot \text{deg}$

OR, since we know that the voltage across each element of the load is V_{in} ...

Real power is dissipated only by resistors

$P := \frac{(|V_{in}|)^2}{R}$ $P = 1.21 \cdot \text{kW}$ $Q := \frac{(|V_{in}|)^2}{\omega \cdot L}$ $Q = 1.284 \cdot \text{kVAR}$

$S := P + j \cdot Q$

$S = |S| = \sqrt{P^2 + Q^2} = 1.764 \cdot \text{kVA}$ $\text{pf} = \frac{P}{|S|} = 0.686$

What value of C in parallel with R & L would make $\text{pf} = 1$ ($Q = 0$) ?

$\text{Im}(I) = -11.671 \cdot A$ $X_C := \frac{V_{in}}{\text{Im}(I)}$ $X_C = -9.425 \cdot \Omega = \frac{-1}{\omega \cdot C}$

$\frac{1}{|X_C| \cdot \omega} = 281 \cdot \mu\text{F}$ OR.. $\omega = \frac{1}{\sqrt{L \cdot C}}$ $C := \frac{1}{L \cdot \omega^2}$ $C = 281 \cdot \mu\text{F}$

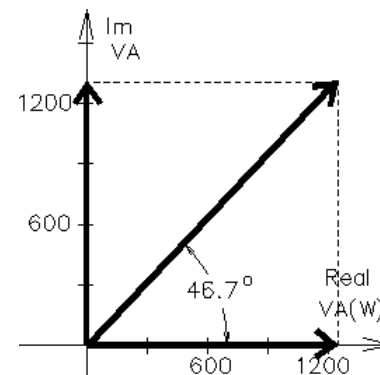

Ex. 2 R & L together are the load. Find the real power P, the reactive power Q, the complex power S, the apparent power |S|, & the power factor pf. Draw phasor diagram for the power.

Series R & L

$V_{in} := 110 \cdot V$
 $\omega := 377 \cdot \frac{\text{rad}}{\text{sec}}$

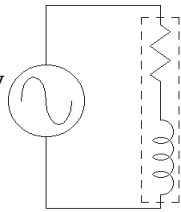

$R := 10 \cdot \Omega$ $Z := R + j \cdot \omega \cdot L$
 $L := 25 \cdot \text{mH}$ $Z = 10 + 9.425j \cdot \Omega$ $|Z| = 13.742 \cdot \Omega$

$\theta := \arg(Z)$ $\theta = 43.304 \cdot \text{deg}$ $\text{pf} := \cos(\theta)$ $\text{pf} = 0.728$

$I := \frac{V_{in}}{Z}$ $I = 5.825 - 5.49j \cdot A$

$|I| = 8.005 \cdot A$ $\arg(I) = -43.304 \cdot \text{deg}$

$P := |V_{in}| \cdot |I| \cdot \text{pf}$ $P = 0.641 \cdot \text{kW}$

$Q := |V_{in}| \cdot |I| \cdot \sin(\theta)$ $Q = 0.604 \cdot \text{kVAR}$

$S := V_{in} \cdot \bar{I}$ $S = 0.641 + 0.604j \cdot \text{kVA}$

$|S| = 0.881 \cdot \text{kVA}$ $\arg(S) = 43.304 \cdot \text{deg}$ $S = 881 \text{VA} / 43.3^\circ$

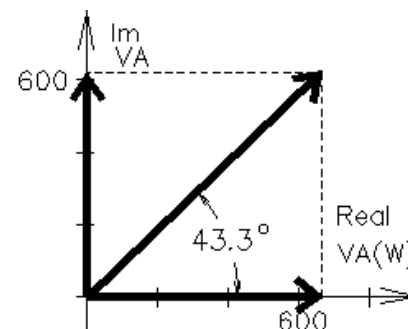

ECE 3600 AC Power Examples, p.2

OR, if we first find the magnitude of the current which flows through each element of the load...

$$|\mathbf{I}| = \frac{V_{in}}{\sqrt{R^2 + (\omega \cdot L)^2}} = 8.005 \cdot A$$

$$P := (|\mathbf{I}|)^2 \cdot R \quad P = 0.641 \cdot kW \quad Q := (|\mathbf{I}|)^2 \cdot (\omega \cdot L) \quad Q = 0.604 \cdot kVAR$$

$$\mathbf{S} := P + j \cdot Q \quad |\mathbf{S}| = \sqrt{P^2 + Q^2} = 0.881 \cdot kVA \quad pf = \frac{P}{|\mathbf{S}|} = 0.728$$

What value of C in parallel with R & L would make $pf = 1$ ($Q = 0$) ?

$$Q = 603.9 \cdot VAR \quad \text{so we need: } Q_C := -Q \quad Q_C = -603.9 \cdot VAR = \frac{V_{in}^2}{X_C}$$

$$X_C := \frac{V_{in}^2}{Q_C} \quad X_C = -20.035 \cdot \Omega = \frac{-1}{\omega \cdot C} \quad C := \frac{1}{|X_C| \cdot \omega} \quad C = 132 \cdot \mu F$$

$$\text{Check: } \frac{1}{\frac{1}{R + j \cdot \omega \cdot L} + j \cdot \omega \cdot C} = 18.883 \cdot \Omega \quad \text{No } j \text{ term, so } \theta = 0^\circ$$

Ex. 3 R, & C together are the load in the circuit shown.

The RMS voltmeter measures 240 V, the RMS ammeter measures 3 A, and the wattmeter measures 600 W. Find the following: Be sure to show the correct units for each value.

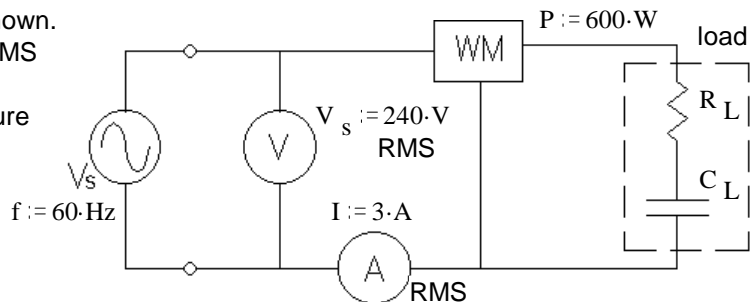

a) The value of the load resistor. $R_L = ?$

$$P = I^2 \cdot R_L$$

$$R_L := \frac{P}{I^2} \quad R_L = 66.7 \cdot \Omega$$

b) The apparent power. $|\mathbf{S}| = ?$

$$\mathbf{S} := V_s \cdot I \quad S = 720 \cdot VA$$

c) The reactive power. $Q = ?$

$$Q := -\sqrt{S^2 - P^2} \quad Q = -398 \cdot VAR$$

d) The complex power. $\mathbf{S} = ?$

$$\mathbf{S} := P + j \cdot Q \quad \mathbf{S} = 600 - 398j \cdot VA$$

e) The power factor. $pf = ?$

$$pf := \frac{P}{V_s \cdot I} \quad pf = 0.833$$

f) The power factor is leading or lagging? leading (load is capacitive, Q is negative)

g) The two components of the load are in a box which cannot be opened. Add (draw it) another component to the circuit above which can correct the power factor (make $pf = 1$). Show the correct component in the correct place and find its value. This component should not affect the real power consumption of the load.

Add an inductor in parallel with load

$$f = 60 \cdot Hz \quad \omega := 2 \cdot \pi \cdot f \quad \omega = 376.991 \cdot \frac{rad}{sec}$$

$$Q = -398 \cdot VAR \quad \text{so we need: } Q_L := -Q \quad Q_L = 398 \cdot VAR = \frac{V_s^2}{X_L}$$

$$X_L := \frac{V_s^2}{Q_L} \quad X_L = 144.725 \cdot \Omega = \omega \cdot L \quad L := \frac{|X_L|}{\omega} \quad L = 384 \cdot mH$$

Ex. 4 For the 60 Hz load shown in the figure, the RMS voltmeter measures 120 V. The phasor diagram for the power is also shown. Find the following:

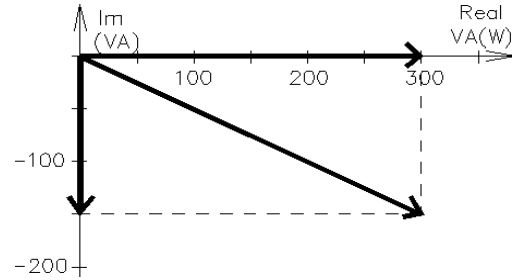
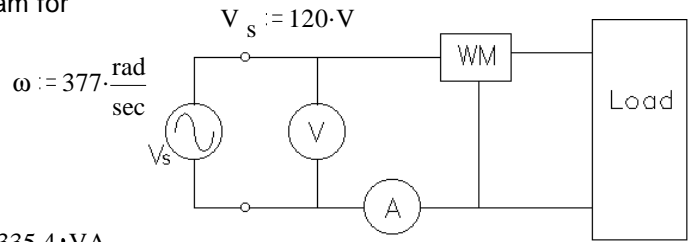

a) The complex power. $S = ?$

$$P := 300 \cdot \text{W} \quad Q := -150 \cdot \text{VA}$$

$$S := P + j \cdot Q \quad S = 300 - 150j \cdot \text{VA}$$

b) The apparent power. $|S| = ? \quad |S| = \sqrt{P^2 + Q^2} = 335.4 \cdot \text{VA}$

c) The power factor. $\text{pf} = ? \quad \text{pf} := \frac{P}{|S|} \quad \text{pf} = 0.894$

d) The item marked "WM" in the figure is a wattmeter, what does it read? (give a number) $P = 300 \cdot \text{W}$

e) The item marked "A" in the figure is an RMS ammeter, what does it read? (give a number)

$$I := \frac{|S|}{V_s} \quad I = 2.795 \cdot \text{A} \quad I = 2.8 \cdot \text{A}$$

f) The power factor is leading or lagging? leading (Q is negative)

g) The 3 components of the load are in a box which cannot be opened. Add another component to the circuit above which can correct the power factor (make $\text{pf} = 1$). Show the correct component in the correct place and find its value. This component should not affect the real power consumption of the load.

Add an inductor in parallel with load

$$Q = -150 \cdot \text{VAR} \quad \text{need: } Q_L := -Q \quad Q_L = 150 \cdot \text{VAR} = \frac{V_s^2}{\omega \cdot L} \quad L := \frac{V_s^2}{\omega \cdot Q_L} \quad L = 255 \cdot \text{mH}$$

Ex. 5 R, L, & C together are the load in the circuit shown

The RMS voltmeter measures 120 V. $V_s := 120 \cdot \text{V}$

The wattmeter measures 270 W. $P := 270 \cdot \text{W}$

The RMS ammeter measures 3.75 A. $I := 3.75 \cdot \text{A}$

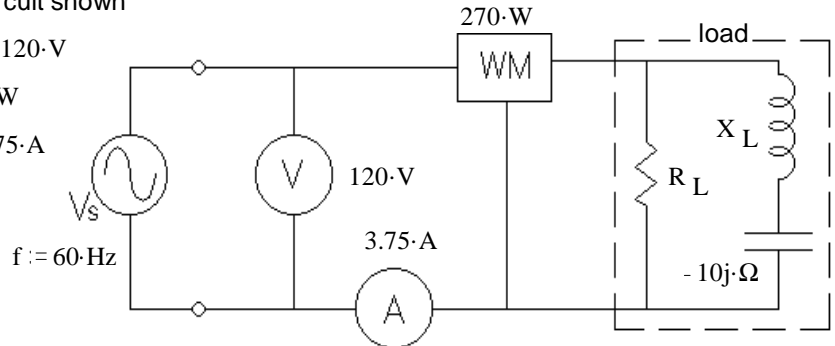

Find the following: Be sure to show the correct units for each value.

a) The value of the load resistor. $R_L = ?$

$$P = \frac{V_s^2}{R_L} \quad R_L := \frac{V_s^2}{P} \quad R_L = 53.3 \cdot \Omega$$

b) The magnitude of the impedance of the load inductor (reactance). $|Z_L| = X_L = ?$

$$I_R := \frac{V_s}{R_L} \quad I_R = 2.25 \cdot \text{A} \quad I_L := \sqrt{I^2 - I_R^2} \quad I_L = 3 \cdot \text{A} \quad X := \frac{V_s}{I_L} \quad X = 40 \cdot \Omega$$

$$X_C := -10 \cdot \Omega \quad X_L := X - X_C \quad X_L = 50 \cdot \Omega$$

c) The reactive power. $Q = ? \quad Q := \sqrt{(V_s \cdot I)^2 - P^2} \quad Q = 360 \cdot \text{VAR} \quad \text{positive, because the load is primarily inductive}$

d) The power factor is leading or lagging? lagging (load is inductive, Q is positive)

ECE 3600 AC Power Examples, p.4

e) The 3 components of the load are in a box which cannot be opened. Add another component to the circuit above which can correct the power factor (make pf = 1). Show the correct component in the correct place and find its value. This component should not affect the real power consumption of the load.

Add a capacitor in parallel with load

$$f = 60 \text{ Hz} \quad \omega := 2 \cdot \pi \cdot f \quad \omega = 376.991 \frac{\text{rad}}{\text{sec}}$$

$$Q = 360 \text{ VAR} \quad \text{so we need: } Q_C := -Q \quad Q_C = -360 \text{ VAR} = -\frac{V_s^2}{\omega \cdot C} = -\omega \cdot C \cdot V_s^2$$

$$C := \frac{Q_C}{-\omega \cdot V_s^2} \quad C = 66.3 \mu\text{F}$$

Ex. 6 An inductor is used to completely correct the power factor of a load.

Find the following:

a) The power consumed by the load. $P_L = ?$

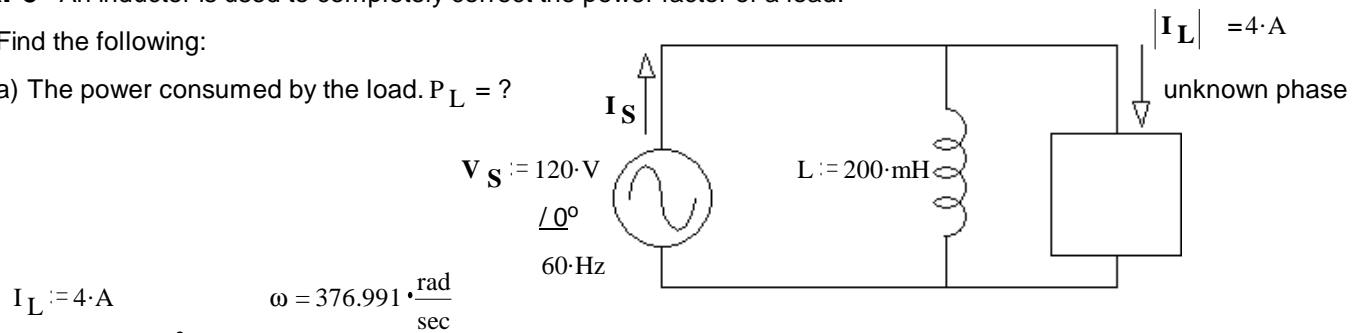

$$I_L := 4 \text{ A} \quad \omega = 376.991 \frac{\text{rad}}{\text{sec}}$$

$$Q_L := \frac{(|V_S|)^2}{\omega \cdot L} \quad Q_L = 190.986 \text{ VAR} \quad Q_{\text{load}} := -Q_L$$

$$S_L := |V_S| \cdot I_L \quad S_L = 480 \text{ VA} \quad P_L := \sqrt{S_L^2 - Q_{\text{load}}^2} \quad P_L = 440.4 \text{ W}$$

b) The power supplied by the source. $P_S = P_L = 440 \text{ W}$

c) The source current (magnitude and phase). $I_S := \frac{P_L}{V_S} \quad I_S = 3.67 \text{ A} \quad \angle 0^\circ$
because the source sees a pf = 1

d) The load can be modeled as 2 parts in parallel. Draw the model and find the values of the parts.

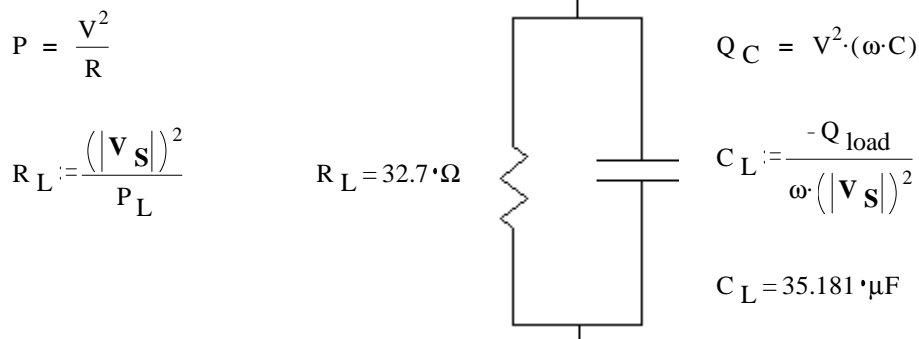

e) The inductor, L, is replaced with a 50 mH inductor.

- i) The **new** source current $|I_S|$ is **greater** than that calculated in part c). <-- Answer
- circle one ii) The **new** source current $|I_S|$ is **the same** as that calculated in part c).
- iii) The **new** source current $|I_S|$ is **less** than that calculated in part c).

ECE 3600 AC Power Examples, p.5

Ex. 7 C, R₁, & R₂ together are the load (in dotted box). The reactive power used by the load is

$$Q_{\text{load}} := -600 \cdot \text{VAR} \quad \text{Find:}$$

a) The real power used by the load. $P_{\text{load}} = ?$

$$X_C := -10 \cdot \Omega$$

$$|I_C| = I_C := \frac{Q_{\text{load}}}{X_C} \quad I_C = 7.746 \cdot \text{A}$$

$$V_{\text{load}} := I_C \cdot \sqrt{R_1^2 + X_C^2} \quad V_{\text{load}} = 90.333 \cdot \text{V}$$

$$P_{\text{load}} := I_C^2 \cdot R_1 + \frac{V_{\text{load}}^2}{R_2} \quad P_{\text{load}} = 1.38 \cdot \text{kW}$$

b) The apparent power of the load. $|S| = S := \sqrt{P_{\text{load}}^2 + Q_{\text{load}}^2} \quad S = 1.505 \cdot \text{kVA}$

c) The power factor of the load. $\text{pf} := \frac{P_{\text{load}}}{S} \quad \text{pf} = 0.917$

d) This power factor is: i) leading ii) lagging Leading, capacitor

e) The voltage at the load (magnitude). $V_{\text{load}} = 90.333 \cdot \text{V}$ found above

f) The magnitudes of the three currents. $|I_C| = ? \quad |I_{R2}| = ? \quad |I_S| = ?$

$$|I_C| = I_C = 7.746 \cdot \text{A} \quad \text{found above}$$

$$|I_{R2}| = I_{R2} = \frac{V_{\text{load}}}{R_2} = 11.292 \cdot \text{A}$$

$$|I_S| = I_S := \frac{S}{V_{\text{load}}} \quad I_S = 16.658 \cdot \text{A}$$

g) The source voltage (magnitude). $V_S = ?$

$$P_{\text{Line}} := I_S^2 \cdot R_{\text{line}} \quad P_{\text{Line}} = 111 \cdot \text{W}$$

$$Q_{\text{Line}} := I_S^2 \cdot X_{\text{line}} \quad Q_{\text{Line}} = 555 \cdot \text{VAR}$$

$$|S_S| = S_S := \sqrt{(P_{\text{load}} + P_{\text{Line}})^2 + (Q_{\text{load}} + Q_{\text{Line}})^2} \quad S_S = 1.492 \cdot \text{kVA}$$

$$V_S := \frac{S_S}{I_S} \quad V_S = 89.546 \cdot \text{V}$$

h) Is there something weird about this voltage? If so, what? V_S is less than V_{Load}

Why? Because the Q of the line partially cancels the Q of the load

OR Partial resonance between the inductance in the line and the capacitance of the load.

i) The efficiency. $\eta = ?$

When asked for efficiency, assume the power used by R_{line} is a loss and P_{load} is the output power.

$$\eta = \frac{P_{\text{out}}}{P_{\text{in}}} = \frac{P_{\text{out}}}{P_{\text{out}} + P_{\text{loss}}} = \frac{P_{\text{load}}}{P_{\text{load}} + P_{\text{Line}}} = 92.56\%$$

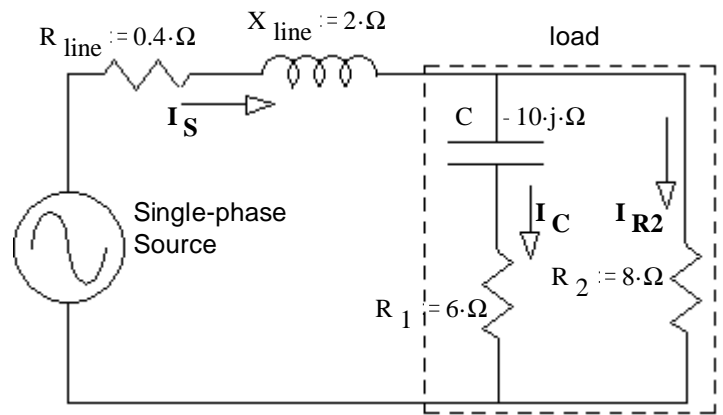

ECE 3600 AC Power Examples, p.6

Ex. 8 In the circuit shown, the ideal voltmeter, V, reads 120V and ideal ammeter, A, reads 5A.

$$S_{load} := 120 \cdot V \cdot 5 \cdot A \quad S_{load} = 600 \cdot VA$$

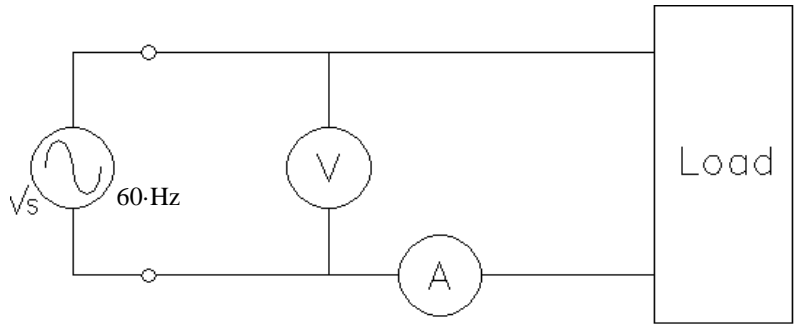

a) You add a capacitor, C, and the ammeter reading changes to 5.3A. Find the following:

$$P_{load} = ? \quad Q_{load} = ?$$

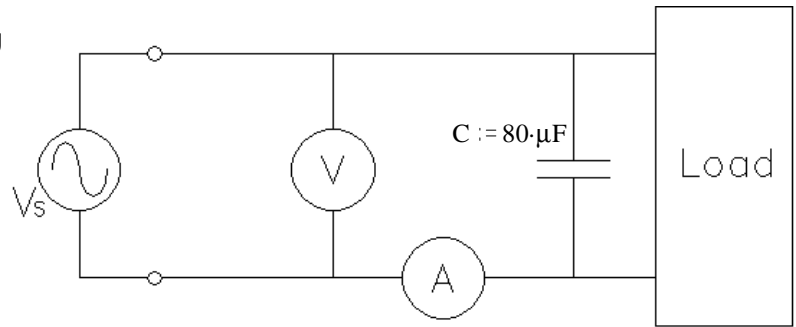

I_C is **NOT** 0.3A, That's subtracting magnitudes

$$S_{load} := 120 \cdot V \cdot 5 \cdot A \quad S_{load} = 600 \cdot VA = \sqrt{P_{load}^2 + Q_{load}^2}$$

$$OR \quad (600 \cdot VA)^2 = P_{load}^2 + Q_{load}^2$$

$$P_{load}^2 = (600 \cdot VA)^2 - Q_{load}^2$$

$$Q_C := \frac{(120 \cdot V)^2}{\left(-\frac{1}{\omega \cdot C}\right)} = -(120 \cdot V)^2 \cdot \omega \cdot C \quad Q_C = -434.294 \cdot VAR$$

With Capacitor:

$$S_S := 120 \cdot V \cdot 5.3 \cdot A \quad S_S = 636 \cdot VA = \sqrt{P_{load}^2 + (Q_{load} + Q_C)^2}$$

$$OR \quad (636 \cdot VA)^2 = P_{load}^2 + (Q_{load} + Q_C)^2$$

$$\begin{aligned} \text{Substitute in} \quad (636 \cdot VA)^2 &= \left[(600 \cdot VA)^2 - Q_{load}^2 \right] + (Q_{load} + Q_C)^2 \\ &= \left[(600 \cdot VA)^2 - Q_{load}^2 \right] + (Q_{load}^2 + 2 \cdot Q_C \cdot Q_{load} + Q_C^2) \\ &= (600 \cdot VA)^2 + 2 \cdot Q_C \cdot Q_{load} + Q_C^2 \end{aligned}$$

$$Q_{load} := \frac{(636 \cdot VA)^2 - (600 \cdot VA)^2 - Q_C^2}{2 \cdot Q_C} \quad Q_{load} = 165.919 \cdot VAR$$

$$P_{load} := \sqrt{S_{load}^2 - Q_{load}^2} \quad P_{load} = 576.603 \cdot W$$

$$\text{Double Check: } S_S = \sqrt{P_{load}^2 + (Q_{load} + Q_C)^2} = 636 \cdot VA$$

The power factor was way over corrected by $C = 80 \cdot \mu F$