

# ECE 3600 3-Phase Power notes

Single phase power pulses at 120 Hz. This is not suitable for motors or generators over about 5 hp.

Two-phase power is constant as long as the two loads are balanced.

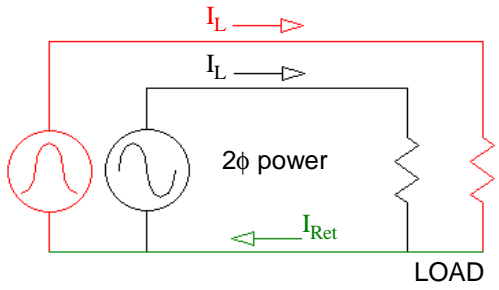

But, the return current is larger than either load current.

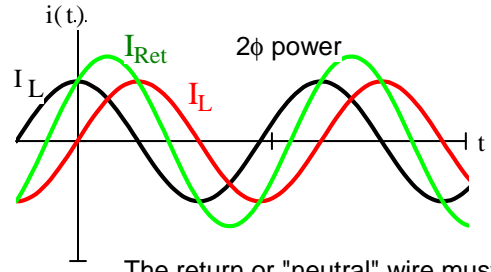

The return or "neutral" wire must be thicker than either "hot" line.

## 3-Phase Power

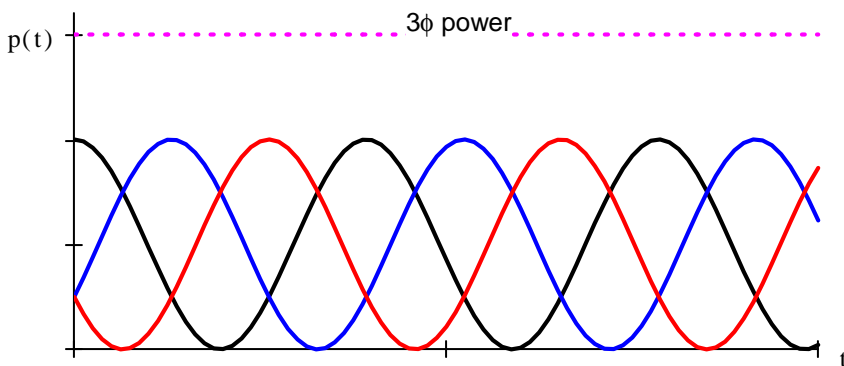
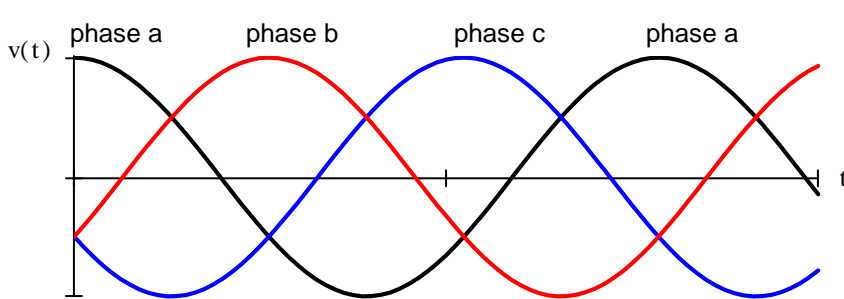
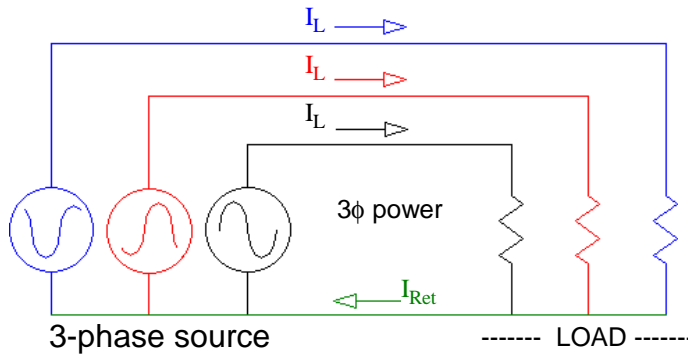

Three phase power is constant as long as the three loads are balanced.

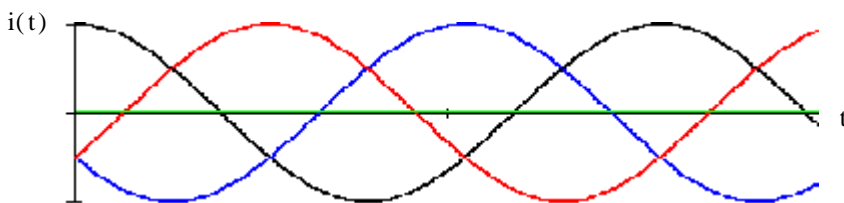

If loads are balanced, ground return current will be zero.

If the loads are close to balanced the relatively small return current can be carried by the earth ground.

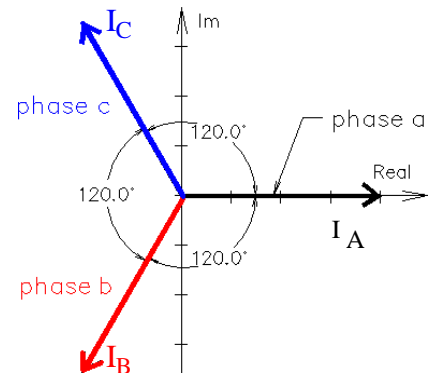
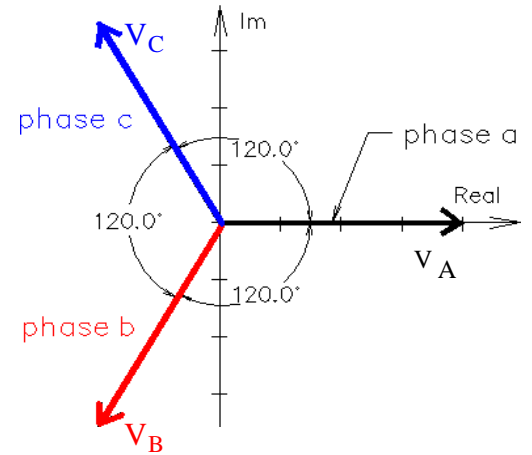

**Basics**

Single phase power pulses at 120 Hz. This is not good for motors or generators over about 5 hp.

Three phase power is constant as long as the three loads are balanced.

Three lines are needed to transmit 3-phase power. If loads are balanced, ground return current will be zero.

The 3 lines coming into your house are **NOT** 3-phase. They are +120 V, Gnd, -120 V

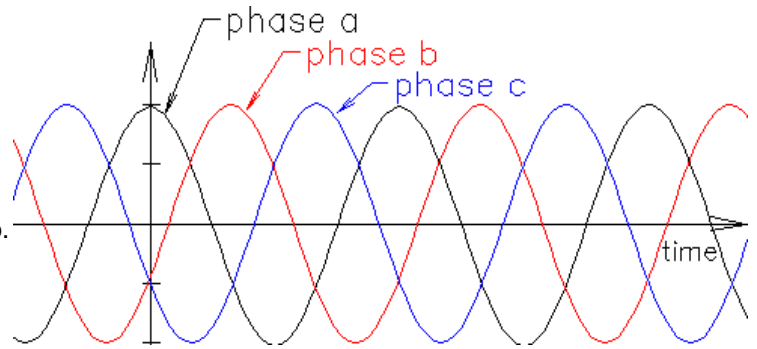

(The two 120s are 180° out-of-phase, allowing for 240 V connections)

3-phase outlets have 4 connections

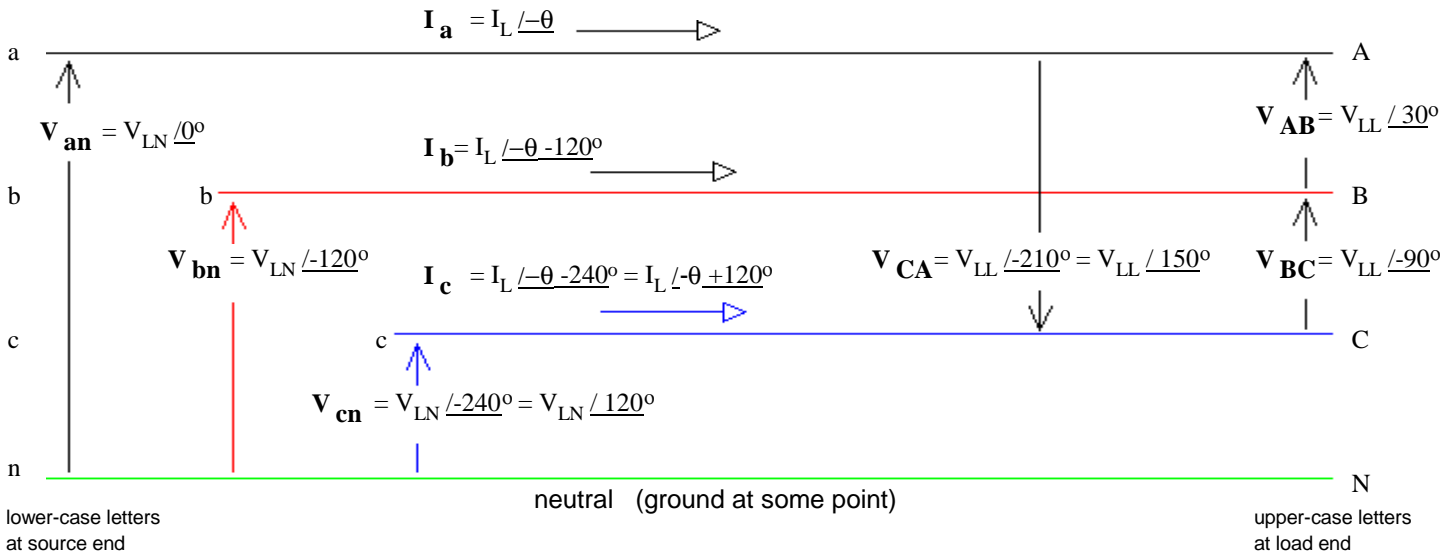

**Connections to the 3 Lines**

Wye connection:

Connect each load or generator phase between a line and ground.

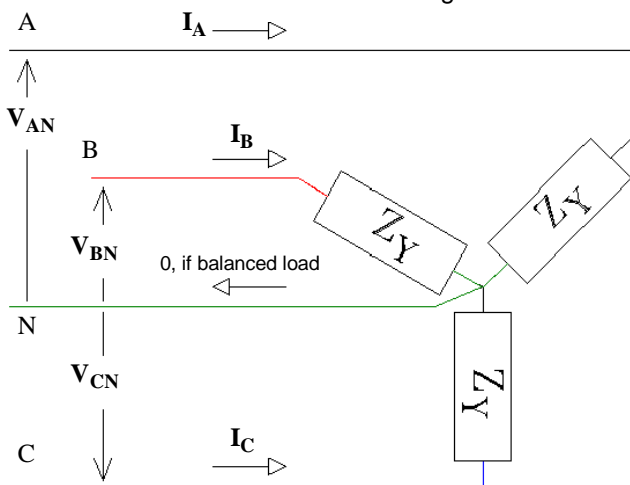

Delta connection:

Connect each load or generator phase between two lines.

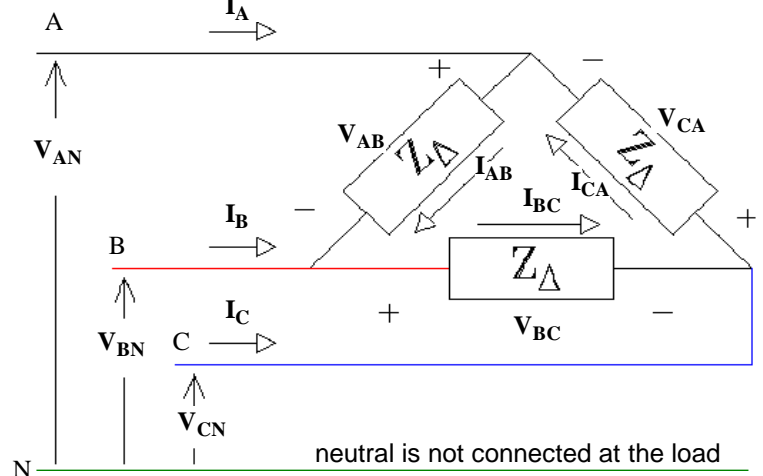

$$|V_{AN}| = |V_{BN}| = |V_{CN}| = V_{LN} = \frac{V_{LL}}{\sqrt{3}} = \frac{V_L}{\sqrt{3}}$$

$$|V_{AB}| = |V_{BC}| = |V_{CA}| = V_{LL} = \sqrt{3} \cdot V_{LN} = V_L$$

$$|I_A| = |I_B| = |I_C| = I_L = \sqrt{3} \cdot I_{LL}$$

$$|I_{AB}| = |I_{BC}| = |I_{CA}| = I_{LL} = \frac{I_L}{\sqrt{3}}$$

To get equivalent line currents with equivalent voltages:  $Z_Y = \frac{Z_\Delta}{3}$        $Z_\Delta = 3 \cdot Z_Y$

Wye, Y, connection:

Connect each load or generator phase between a line and ground.

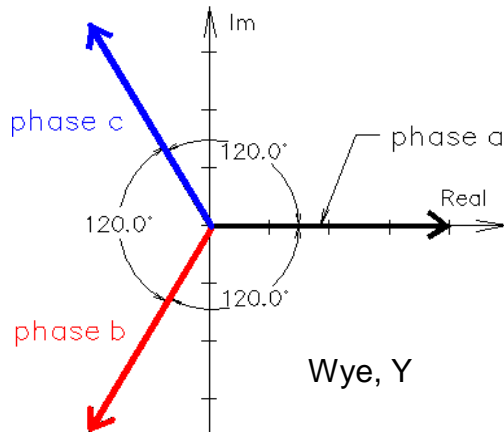

$$V_{LN} = \frac{V_{LL}}{\sqrt{3}} \quad I_L = \sqrt{3} \cdot I_{LL} \quad (\Delta\text{-connection})$$

Delta, Δ, connection:

Connect each load or generator phase between two lines.

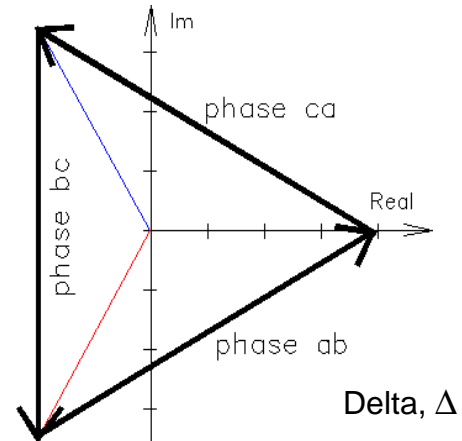

$$V_{LL} = \sqrt{3} \cdot V_{LN} \quad I_{LL} = \frac{I_L}{\sqrt{3}}$$

Apparent Power:  $|S_{3\phi}| = 3 \cdot |S_{1\phi}| = 3 \cdot V_{LN} \cdot I_L = 3 \cdot V_{LL} \cdot I_{LL} = \sqrt{3} \cdot V_{LL} \cdot I_L$

Power:  $P_{3\phi} = 3 \cdot P_{1\phi} = 3 \cdot V_{LN} \cdot I_L \cdot \text{pf} = 3 \cdot V_{LL} \cdot I_{LL} \cdot \text{pf} = \sqrt{3} \cdot V_{LL} \cdot I_L \cdot \text{pf} = S_{3\phi} \cdot \text{pf}$   
 $\text{pf} = \cos(\theta)$

Reactive power:  $Q_{3\phi} = 3 \cdot Q_{1\phi} = 3 \cdot V_{LN} \cdot I_L \cdot \sin(\theta) \text{ etc...} = \sqrt{(|S_{3\phi}|)^2 - P_{3\phi}^2}$

Cautions about "L" subscripts:

$I_L$  is always the line current, same as would flow in a Y-connected device.

$V_L$  is always the line-to-line voltage, same as across a Δ-connected device.

When a single phase is taken from a 3-phase panel, then the line voltage ( $V_L$ ) of that single phase is the line-to-neutral voltage of the 3-phase input to that panel, so the value of  $V_L$  changes in the panel (isn't that nice?).

$Z_L$  could be the load impedance, either Y-connected or Δ-connected, or it could be the line impedance--the impedance in the line itself, between the source and the load.

Cautions about "φ" or "ph" subscripts:

In our book:  $V_\phi =$  the voltage across a single phase of a source or load and depends on the connection of that load,  $V_{LN}$  for Y-connected devices and  $V_{LL}$  for Δ-connected devices.

$I_\phi$  Also depends on connection.

In **some** books:  $V_\phi = V_{ph} = V_{LN} \quad I_\phi = I_{ph} =$  current in a Y-connection <-- DON'T USE in this class

Phase sequences:

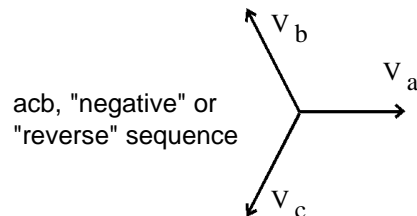
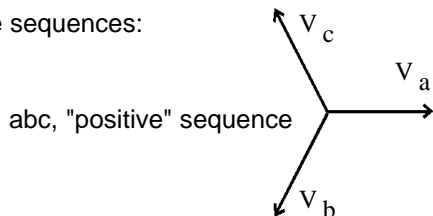

Common usage:  $V_L = V_{LL}$  "line voltage" = line-to-line voltage

An unspecified voltage or a "line" voltage must always be assumed to be line-to-line,

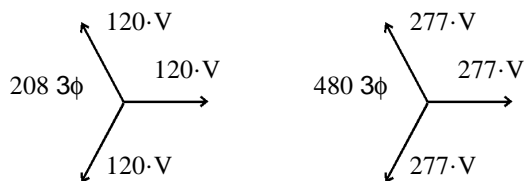

**Our Approach** Only works if system is **Balanced** (Always so in our class)

- 1) Change all  $\Delta$ -connected loads to equivalent Y-connected loads  $Z_Y = \frac{Z_\Delta}{3}$

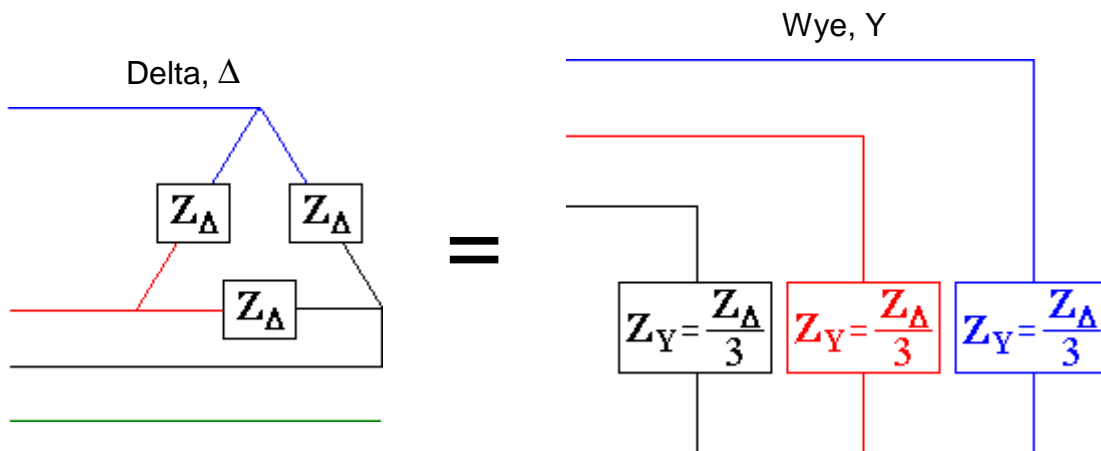

- 2) Find all voltages as  $V_{LN}$ , especially  $V_{LN} = \frac{V_L}{\sqrt{3}}$
- 3) Change all power numbers to 1 $\phi$ .

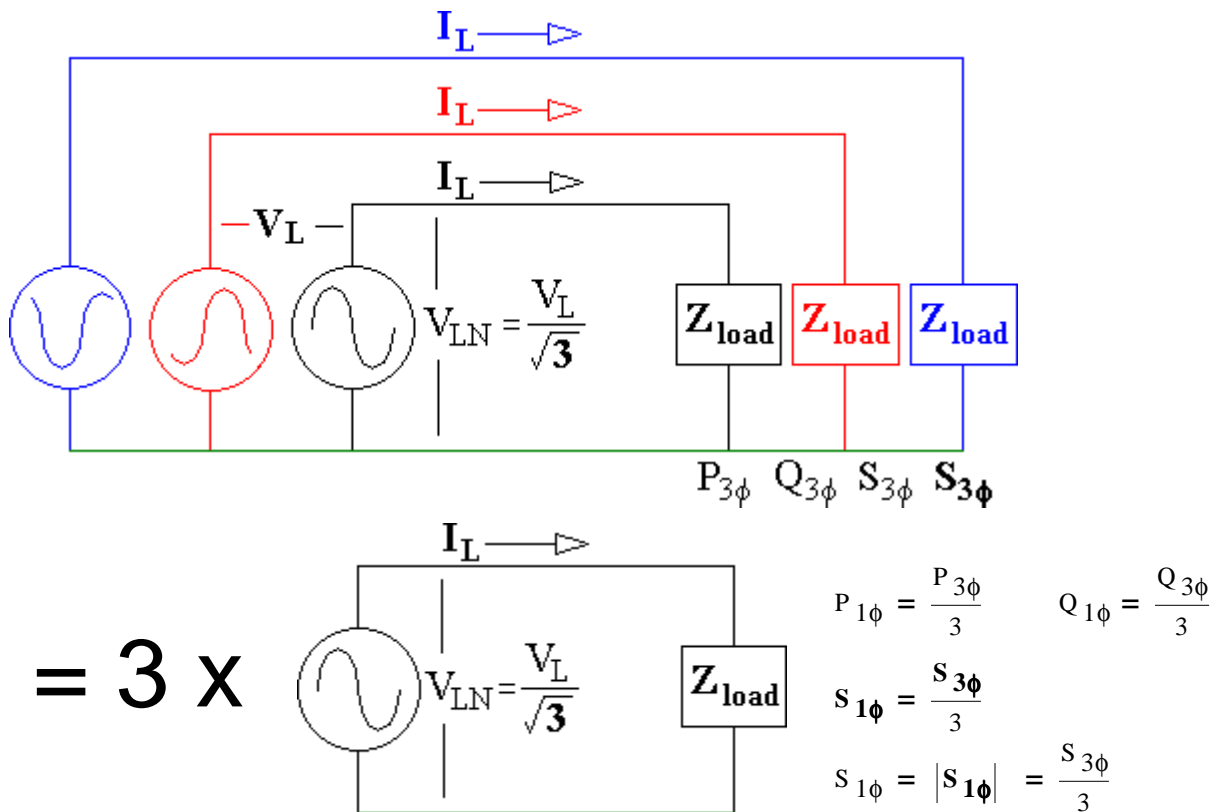

- 4) Solve the remaining single-phase problem.
- 5) Return to "line" voltages and 3 $\phi$  powers, as necessary.

$$V_L = \sqrt{3} \cdot V_{LN}$$

$$P_{3\phi} = 3 \cdot P_{1\phi}$$

$$Q_{3\phi} = 3 \cdot Q_{1\phi}$$

$$|S_{3\phi}| = 3 \cdot |S_{1\phi}|$$

$$S_{3\phi} = 3 \cdot S_{1\phi}$$

In rare cases, you may also need:

$$I_\Delta = I_{LL} = \frac{I_L}{\sqrt{3}}$$

and:  $Z_\Delta = 3 \cdot Z_Y$