

ECE 3600 3-Phase Examples

A. Stolp
9/9/09
rev 9/5/20

Ex. 1 A Y-connected load is connected to 208-V, 3-phase.
It draws 1.2kW of power at a power factor of 75%, leading.

$$P_{3\phi} := 1.2 \cdot \text{kW} \quad \text{pf} := 0.75$$

a) Find the apparent power and the reactive power.

$$S_{3\phi} := \frac{P_{3\phi}}{\text{pf}} \quad S_{3\phi} = 1.6 \cdot \text{kVA} \quad Q_{3\phi} := -\sqrt{S_{3\phi}^2 - P_{3\phi}^2} \quad Q_{3\phi} = -1.058 \cdot \text{kVAR}$$

Negative because the power factor is leading.

b) Find the line current.

Our Approach 1) Change all Δ -connected loads to equivalent Y-connected loads $Z_Y = \frac{Z_\Delta}{3}$ NOT NEEDED

2) Find all voltages as $V_{LN} := \frac{208 \cdot \text{V}}{\sqrt{3}} \quad V_{LN} = 120.089 \cdot \text{V}$

3) Change all power numbers to 1 ϕ . $P_{1\phi} := \frac{P_{3\phi}}{3} \quad P_{1\phi} = 400 \cdot \text{W}$
 $Q_{1\phi} := \frac{Q_{3\phi}}{3} \quad Q_{1\phi} = -352.767 \cdot \text{VAR}$
 $S_{1\phi} := \frac{S_{3\phi}}{3} \quad S_{1\phi} = 533.333 \cdot \text{VA}$

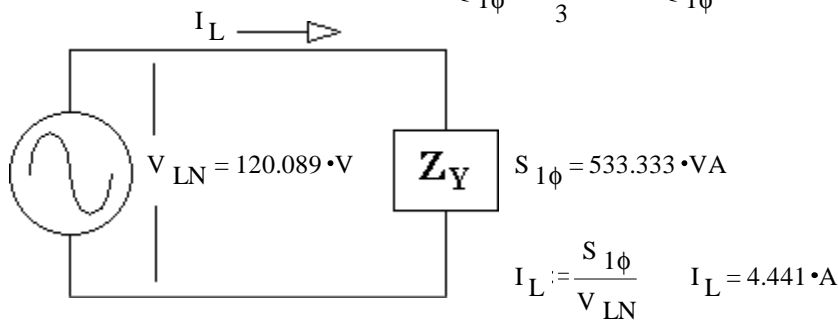

c) Find the values of the load components, assuming they are connected in series.

The components must be a resistor and a capacitor because there is some real power and the power factor is leading.

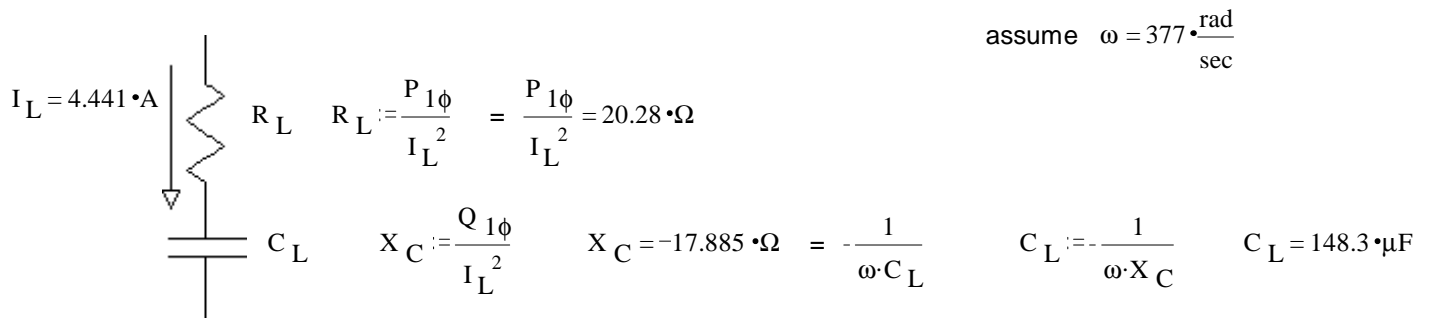

d) Find the values of the load components, assuming they are connected in parallel.

Still a resistor and a capacitor.

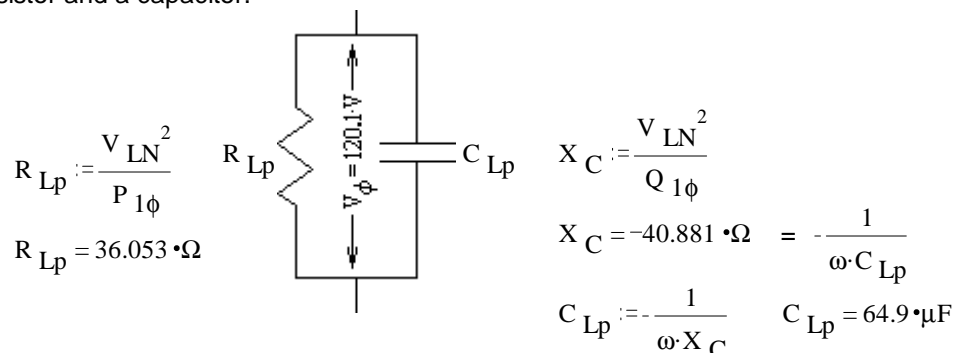

e) Correct the power factor with Y-connected components.
Need inductors

$$Q_{1\phi \text{Ind}} := -Q_{1\phi} = \frac{V_{\phi}^2}{\omega \cdot L_Y} \quad L_Y := \frac{V_{\phi}^2}{\omega \cdot Q_{1\phi}} \quad L_Y = 325.3 \cdot \text{mH}$$

f) Correct the power factor with Δ-connected components.

$$L_{\Delta} := \frac{(\sqrt{3} \cdot V_{\phi})^2}{\omega \cdot Q_{1\phi}} \quad L_{\Delta} = 975.9 \cdot \text{mH}$$

$$\text{OR } \omega \cdot L_{\Delta} = Z_{\Delta} = 3 \cdot Z_Y = 3 \cdot \omega \cdot L_Y \quad 3 \cdot L_Y = 975.9 \cdot \text{mH}$$

Ex. 2 From F08, exam 1, Find the following:

a) The line current that would be measured by an ammeter.

$$V_{LL} := 480 \cdot \text{V} \quad Z_{\Delta} := (30 + 12j) \cdot \Omega$$

Our Approach

1) Change all Δ-connected loads to equivalent Y-connected loads

$$Z_Y := \frac{Z_{\Delta}}{3} \quad Z_Y = 10 + 4j \cdot \Omega$$

2) Find all voltages as $V_{LN} \quad V_{LL} = 480 \cdot \text{V} \quad V_{LN} := \frac{V_{LL}}{\sqrt{3}}$

3) Change all power numbers to 1φ. NOT NEEDED

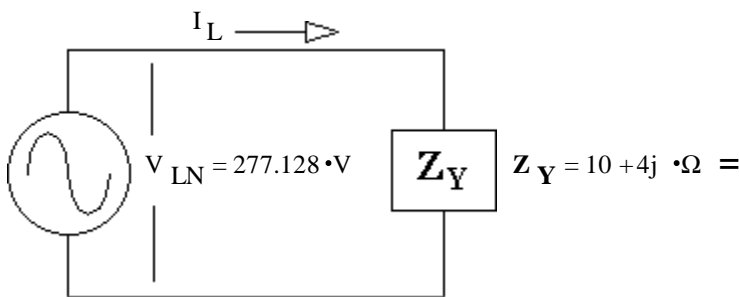

$$I_L := \frac{V_{LN}}{|Z_Y|} = \frac{277.128 \cdot \text{V}}{\sqrt{10^2 + 4^2} \cdot \Omega} = 25.731 \cdot \text{A}$$

b) The power consumed by the three-phase load.

c) The value of Y-connected impedances that would result in exactly the same line currents and same pf.

$$Z_Y = 10 + 4j \cdot \Omega$$

d) The value of Y-connected capacitors that would correct the pf.

$$Q_{1\phi} := \sqrt{S_{1\phi}^2 - P_{1\phi}^2} \quad Q_{1\phi} := \sqrt{(V_{LN} \cdot I_L)^2 - (6.62 \cdot \text{kW})^2} \quad Q_{1\phi} = 2.65 \cdot \text{kVAR}$$

so we need:

$$Q_C := -Q_{1\phi} \quad Q_C = -2.65 \cdot \text{kVAR} = -\frac{V_{LN}^2}{\left(\frac{1}{\omega \cdot C}\right)} = -V_{LN}^2 \cdot \omega \cdot C \quad C := \frac{Q_C}{-V_{LN}^2 \cdot \omega} \quad C = 91.5 \cdot \mu\text{F}$$

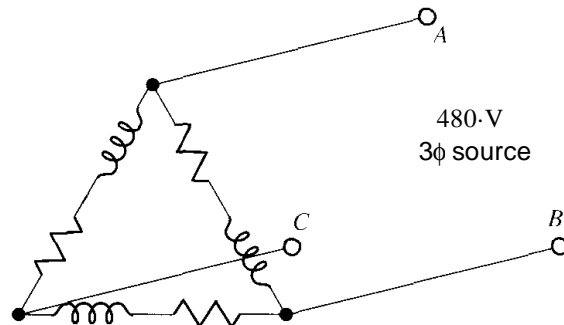

$$\text{All } Z := (30 + 12j) \cdot \Omega$$

$$V_{LN} = 277.128 \cdot \text{V}$$

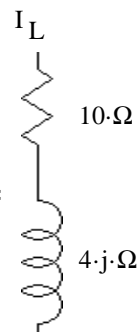

$$I_L = 25.731 \cdot \text{A}$$

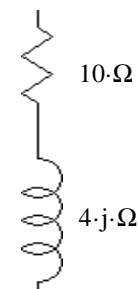

$$P_{1\phi} = I_L^2 \cdot 10 \cdot \Omega = 6.62 \cdot \text{kW}$$

$$P_{3\phi} = 3 \cdot (I_L^2 \cdot 10 \cdot \Omega) = 19.86 \cdot \text{kW}$$

Ex. 3 For the three-phase delta-connected load in fig P1.7, The line-to-line voltage and line current are:

$$\underline{V}_{AB} := 480\text{V} \angle 0^\circ \quad \underline{I}_A = 10\text{A} \angle -40^\circ$$

a) What is \underline{V}_{CA} ?

Normal phase angles

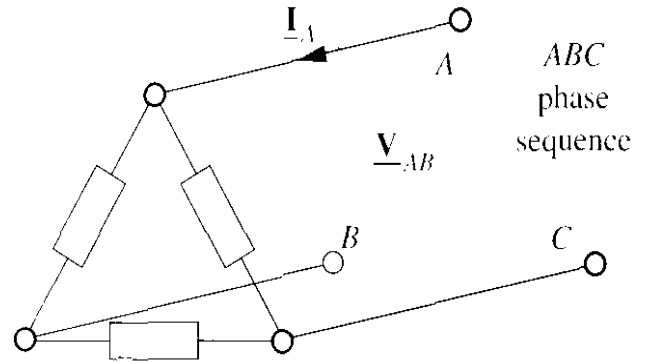
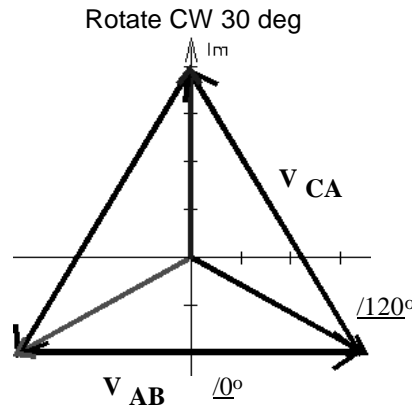
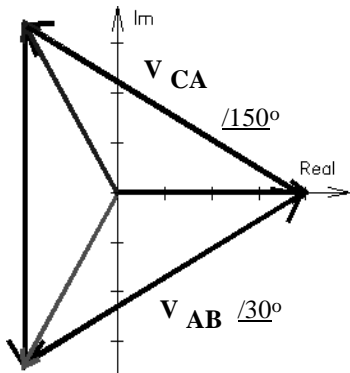

Figure P1.7

$$\begin{aligned} \underline{V}_{CA} &:= 480\text{V} \angle 120^\circ \\ &= 480\text{V} \angle -240^\circ \end{aligned}$$

b) What is the phase current in the load?

$$I_{LL} = \frac{I_L}{\sqrt{3}} = \frac{10\text{A}}{\sqrt{3}} = 5.774\text{A}$$

c) What is the time-average power into the load?

$$\underline{V}_{AN} := \frac{480\text{V}}{\sqrt{3}} \angle -30^\circ \quad \text{Since } \underline{I}_A = 10\text{A} \angle -40^\circ$$

\underline{I} lags \underline{V} by 10°
 $\theta := 10\text{-deg}$

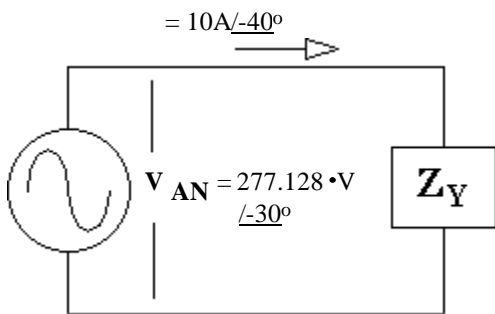
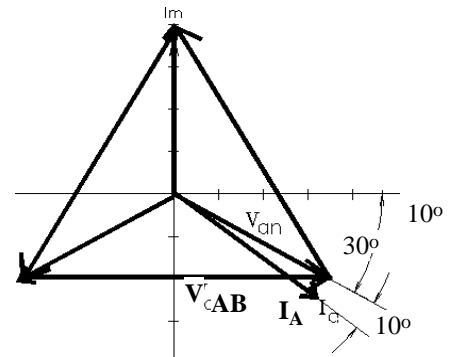

$$P_{1\phi} = (277.128\text{V} \cdot 10\text{A}) \cdot \cos(\theta) = 2.729\text{kW}$$

$$P_{3\phi} = 3 \cdot (277.128\text{V} \cdot 10\text{A}) \cdot \cos(\theta) = 8.188\text{kW}$$

d) What is the phase impedance?

$$\underline{Z}_Y := \frac{277.128\text{V}}{10\text{A}} \angle_{-30 - (-40)} = 27.71\Omega \angle 10^\circ$$

$$\underline{Z}_\Delta = 3 \cdot \underline{Z}_Y = 83.14\Omega \angle 10^\circ$$

Ex. 4 In the three-phase circuit shown in Fig. P1.9. find the following:

a) The line current that would be measured by an ammeter.

Direct way

$$V_{LL} := 600 \cdot \text{V} \quad Z_{\Delta} := (20 + 11j) \cdot \Omega$$

$$I_{AB} := \left| \frac{V_{LL}}{Z_{\Delta}} \right| \quad I_{AB} = 26.286 \cdot \text{A}$$

$$I_A := \sqrt{3} \cdot I_{AB} \quad I_A = 45.53 \cdot \text{A}$$

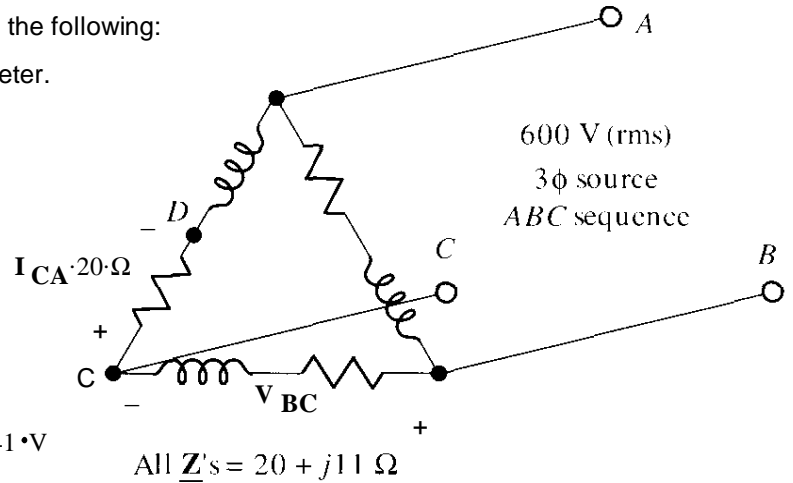
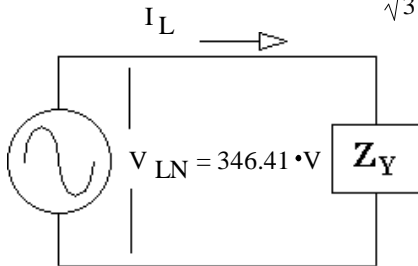

Figure P1.9

Our Approach

$$V_{LN} := \frac{600 \cdot \text{V}}{\sqrt{3}} \quad V_{LN} = 346.41 \cdot \text{V}$$



$$Z_Y := \frac{Z_{\Delta}}{3} \quad Z_Y = 6.667 + 3.667j \cdot \Omega$$

$$I_L := \frac{V_{LN}}{|Z_Y|} = \frac{346.41 \cdot \text{V}}{\sqrt{6.667^2 + 3.667^2}} \quad I_L = 45.53 \cdot \text{A}$$

b) The power factor of the three-phase load.

$$\theta := \text{atan}\left(\frac{11}{20}\right) \quad \theta = 28.811 \cdot \text{deg} \quad \text{pf} \cos(\theta) = 0.876$$

c) The voltage that would be measured between B and D by a voltmeter.

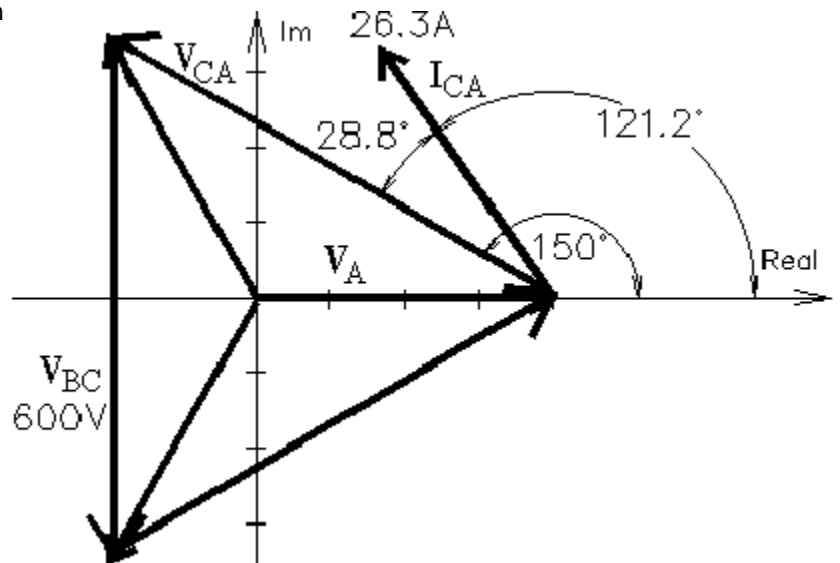
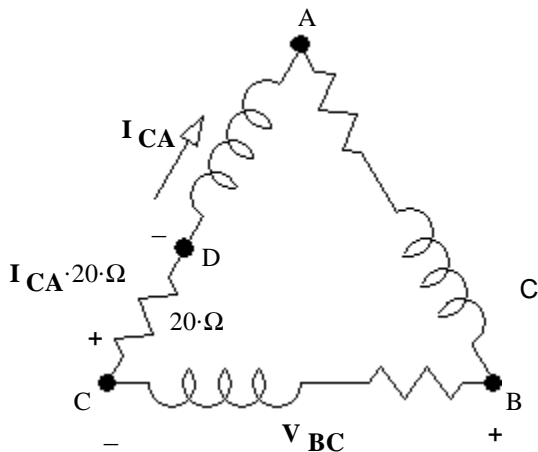

Using V_A as reference (0°):

$$V_{BC} := 600 \cdot \text{V} \cdot e^{-j \cdot 90 \cdot \text{deg}}$$

$$I_{CA} := 26.286 \cdot \text{A} \cdot e^{j \cdot (150 - 28.811) \cdot \text{deg}}$$

$$V_{CD} := I_{CA} \cdot 20 \cdot \Omega$$

$$V_{CD} = -272.251 + 449.734j \cdot \text{V}$$

$$V_{BD} := V_{BC} + V_{CD} \quad V_{BD} = -272.251 - 150.266j \cdot \text{V} \quad |V_{BD}| = 311 \cdot \text{V}$$

(must be the sum, NOT the difference, see the + and - signs on the drawing.)

Ex. 5 When all you have is impedances and an input voltage, it gets messy & luckily, it's not a common problem.

Textbook problem 2-2. Figure P2-1 shows a three-phase power system with two loads. The Δ -connected generator is producing a line voltage of 480 V, and the line impedance is $0.09 + j0.16 \Omega$. Load 1 is Y-connected, with a phase impedance of $2.5 \Omega \angle 36.87^\circ$ and load 2 is Δ -connected, with a phase impedance of $5 \Omega \angle -20^\circ$.

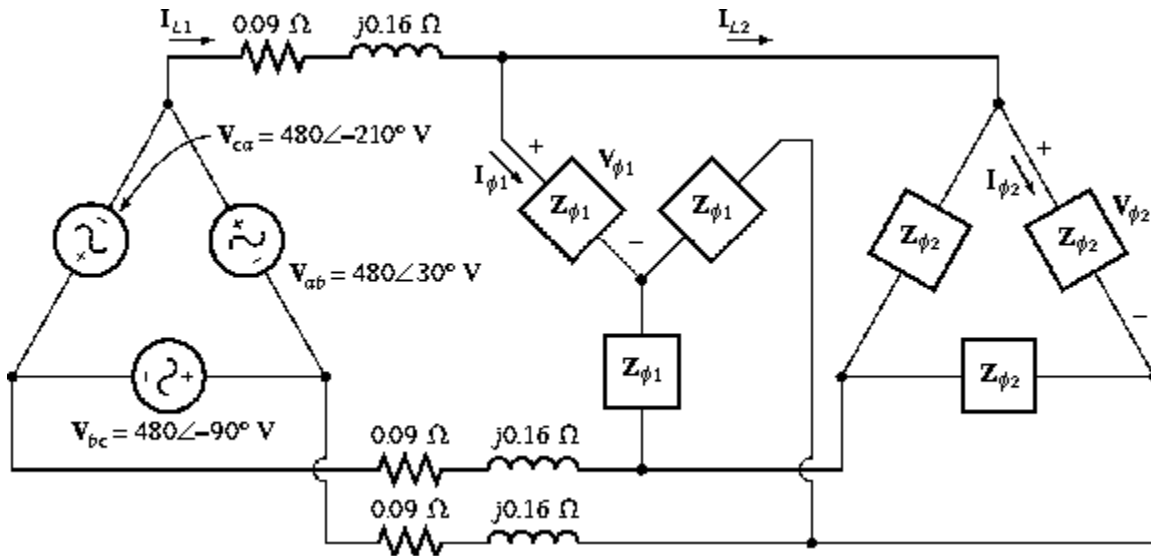

$$Z_{\phi 1} := 2.5 \cdot e^{j \cdot 36.87 \cdot \text{deg}} \cdot \Omega$$

$$Z_{\phi 2} := 5 \cdot e^{-j \cdot 20 \cdot \text{deg}} \cdot \Omega$$

a) What is the line voltage at the two loads?

Find an equivalent Y-only circuit: $Z_{\text{line}} := (0.09 + 0.16j) \cdot \Omega$

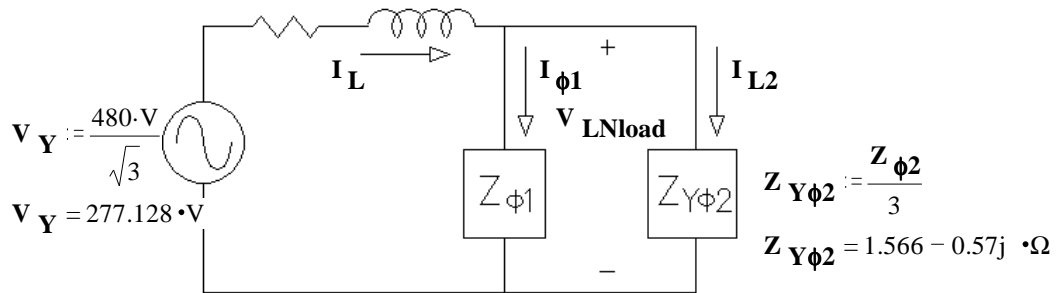

$$Z_{\text{Yloads}} := \frac{1}{\frac{1}{Z_{\phi 1}} + \frac{1}{Z_{\text{Y}\phi 2}}}$$

$$Z_{\text{Yloads}} = 1.13 + 0.044j \cdot \Omega$$

$$|Z_{\text{Yloads}}| = 1.131 \cdot \Omega$$

$$\arg(Z_{\text{Yloads}}) = 2.254 \cdot \text{deg}$$

$$Z_{\text{Ytot}} := Z_{\text{line}} + Z_{\text{Yloads}}$$

$$Z_{\text{Ytot}} = 1.22 + 0.204j \cdot \Omega$$

$$|Z_{\text{Ytot}}| = 1.237 \cdot \Omega$$

$$\arg(Z_{\text{Ytot}}) = 9.516 \cdot \text{deg}$$

$$I_{\text{L}} := \frac{V_{\text{Y}}}{Z_{\text{Ytot}}}$$

$$I_{\text{L}} = 220.998 - 37.047j \cdot \text{A}$$

$$|I_{\text{L}}| = 224.082 \cdot \text{A}$$

$$\arg(I_{\text{L}}) = -9.516 \cdot \text{deg}$$

$$V_{\text{LNload}} := I_{\text{L}} \cdot Z_{\text{Yloads}}$$

$$V_{\text{LNload}} = 251.311 - 32.025j \cdot \text{V}$$

$$|V_{\text{LNload}}| = 253.343 \cdot \text{V}$$

$$\arg(V_{\text{LNload}}) = -7.262 \cdot \text{deg}$$

$$V_{\text{Lload}} := V_{\text{LNload}} \cdot \sqrt{3}$$

$$V_{\text{Lload}} = 435.283 - 55.47j \cdot \text{V}$$

$$|V_{\text{Lload}}| = 438.803 \cdot \text{V}$$

b) What is the voltage drop on the transmission lines?

$$\mathbf{V}_{\text{linedrop}} := \mathbf{I}_{\mathbf{L}} \cdot \mathbf{Z}_{\text{line}} \quad \mathbf{V}_{\text{linedrop}} = 25.817 + 32.025j \cdot \text{V} \quad \begin{aligned} |\mathbf{V}_{\text{linedrop}}| &= 41.136 \cdot \text{V} \\ \arg(\mathbf{V}_{\text{linedrop}}) &= 51.126 \cdot \text{deg} \end{aligned}$$

Check: $\mathbf{V}_{\mathbf{Y}} - \mathbf{V}_{\mathbf{LNload}} = 25.817 + 32.025j \cdot \text{V}$

c) Find the real and reactive powers supplied to each load.

$$\begin{aligned} I_{\phi 1} &:= \frac{|\mathbf{V}_{\mathbf{LNload}}|}{|\mathbf{Z}_{\phi 1}|} & I_{\phi 1} &= 101.337 \cdot \text{A} & I_{\mathbf{L}2} &:= \frac{|\mathbf{V}_{\mathbf{LNload}}|}{|\mathbf{Z}_{\mathbf{Y}\phi 2}|} & I_{\mathbf{L}2} &= 152.006 \cdot \text{A} \\ P_{3\phi 1} &:= 3 \cdot I_{\phi 1}^2 \cdot \text{Re}(\mathbf{Z}_{\phi 1}) & P_{3\phi 1} &= 61.615 \cdot \text{kW} & P_{3\phi 2} &:= 3 \cdot I_{\mathbf{L}2}^2 \cdot \text{Re}(\mathbf{Z}_{\mathbf{Y}\phi 2}) & P_{3\phi 2} &= 108.562 \cdot \text{kW} \\ Q_{3\phi 1} &:= 3 \cdot I_{\phi 1}^2 \cdot \text{Im}(\mathbf{Z}_{\phi 1}) & Q_{3\phi 1} &= 46.212 \cdot \text{kVAR} & Q_{3\phi 2} &:= 3 \cdot I_{\mathbf{L}2}^2 \cdot \text{Im}(\mathbf{Z}_{\mathbf{Y}\phi 2}) & Q_{3\phi 2} &= -39.513 \cdot \text{kVAR} \end{aligned}$$

d) Find the real and reactive power losses in the transmission line.

$$\begin{aligned} P_{3\phi L} &:= 3 \cdot (|\mathbf{I}_{\mathbf{L}}|)^2 \cdot \text{Re}(\mathbf{Z}_{\text{line}}) & P_{3\phi L} &= 13.557 \cdot \text{kW} \\ Q_{3\phi L} &:= 3 \cdot (|\mathbf{I}_{\mathbf{L}}|)^2 \cdot \text{Im}(\mathbf{Z}_{\text{line}}) & Q_{3\phi L} &= 24.102 \cdot \text{kVAR} \end{aligned}$$

e) Find the real power, reactive power, and power factor supplied by the generator.

$$\begin{aligned} P_{3\phi \text{gen}} &:= P_{3\phi L} + P_{3\phi 1} + P_{3\phi 2} & P_{3\phi \text{gen}} &= 183.734 \cdot \text{kW} \\ Q_{3\phi \text{gen}} &:= Q_{3\phi L} + Q_{3\phi 1} + Q_{3\phi 2} & Q_{3\phi \text{gen}} &= 30.801 \cdot \text{kVAR} & \text{pf} &= \frac{P_{3\phi \text{gen}}}{3 \cdot |\mathbf{V}_{\mathbf{Y}}| \cdot |\mathbf{I}_{\mathbf{L}}|} = 0.986 \text{ lagging} \end{aligned}$$

f) What is the efficiency of this system?

$$\eta = \frac{P_{3\phi 1} + P_{3\phi 2}}{P_{3\phi \text{gen}}} = 92.621 \cdot \%$$

The next example uses a "one-line diagram" to show how a generator is connected to 3 loads. In these diagrams, one line represents all 3 phases and neutral. Because the individual lines are not shown, there may be notes or symbols to indicate Y or Δ connections. All powers given will be 3-phase values, all voltages will be line voltages (that is line-to-line) and all currents will be line currents. The term "bus" refers common connection area.

Ex. 6 The one-line diagram below shows a single, Y-connected generator and 3 loads. Assume all lines are lossless.

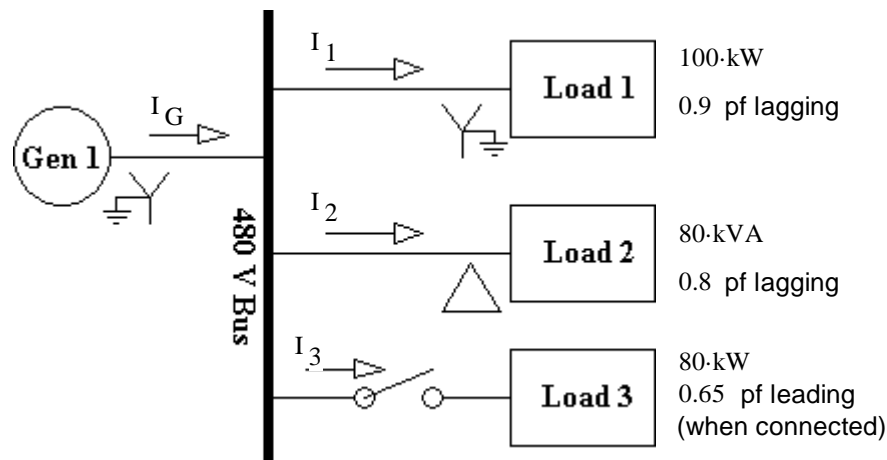

Find:

a) The phase voltage and currents in Load 1.

$$V_{LL} := 480 \cdot V \quad V_{LN} := \frac{V_{LL}}{\sqrt{3}} \quad V_{LN} = 277.128 \cdot V = V_{L1\phi}$$

$$pf_{L1} := 0.9 \quad S_{L1.1\phi} := \frac{100 \cdot kW}{3 \cdot pf_{L1}} \quad I_1 := \frac{S_{L1.1\phi}}{V_{LN}} \quad I_1 = 133.646 \cdot A = I_{L1\phi}$$

b) The phase voltage and currents in Load 2.

$$V_{LL} := 480 \cdot V = V_{L2\phi} \quad pf_{L2} := 0.8 \quad S_{L2.1\phi} := \frac{80 \cdot kVA}{3}$$

$$I_2 := \frac{S_{L2.1\phi}}{V_{LN}} \quad I_2 = 96.225 \cdot A = \sqrt{3} \cdot I_{L2\phi} \quad I_{L2\phi} = \frac{I_2}{\sqrt{3}} = 55.556 \cdot A$$

c) The real, reactive and apparent power supplied by the generator with the switch to load 3 open.

$$P_1 := 100 \cdot kW \quad P_2 := 80 \cdot kVA \cdot pf_{L2} \quad P_2 = 64 \cdot kW \quad P_G := P_1 + P_2 \quad P_G = 164 \cdot kW$$

$$Q_1 := \sqrt{\left(\frac{100 \cdot kW}{pf_{L1}}\right)^2 - (100 \cdot kW)^2} \quad Q_1 = 48.432 \cdot kVAR \quad Q_2 := \sqrt{(80 \cdot kVA)^2 - (64 \cdot kW)^2} \quad Q_2 = 48.432 \cdot kVAR$$

$$Q_G := Q_1 + Q_2 \quad Q_G = 96.432 \cdot kVAR$$

$$S_G := \sqrt{P_G^2 + Q_G^2} \quad S_G = 190.25 \cdot kVAR$$

d) The total line current from the generator, I_G , with the switch to load 3 open.

$$I_G = \frac{\left(\frac{S_G}{3}\right)}{V_{LN}} = 228.836 \cdot A$$

e) The real, reactive and apparent power supplied by the generator with the switch to load 3 closed.

$$pf_{L3} := 0.65 \quad S_{L3.1\phi} := \frac{80 \cdot kW}{3 \cdot pf_{L3}} \quad Q_3 := -\sqrt{\left(\frac{80 \cdot kW}{pf_{L3}}\right)^2 - (80 \cdot kW)^2} \quad Q_3 = -93.53 \cdot kVAR$$

$$P_G := P_1 + P_2 + 80 \cdot kW \quad P_G = 244 \cdot kW \quad Q_G := Q_1 + Q_2 + Q_3 \quad Q_G = 2.902 \cdot kVAR$$

$$S_G := \sqrt{P_G^2 + Q_G^2} \quad S_G = 244.017 \cdot kVAR$$

f) How does the total line apparent power from the generator, S_G , compare to the sum of the three individual apparent powers, $S_1 + S_2 + S_3$? If they aren't equal, why not? (Switch closed)

$$3 \cdot S_{L1.1\phi} + 80 \cdot kVAR + 3 \cdot S_{L3.1\phi} = 314.188 \cdot kVAR \neq S_G = 244.017 \cdot kVAR$$

Can't Add Magnitudes

g) The total line current from the generator, I_G , with the switch to load 3 closed.

$$I_G := \frac{\left(\frac{S_G}{3}\right)}{V_{LN}} \quad I_G = 293.507 \cdot A$$

h) How does the total line current from the generator, I_G , compare to the sum of the three individual currents, $I_1 + I_2 + I_3$? If they aren't equal, why not? (Switch closed)

$$I_3 := \frac{S_{L3.1\phi}}{V_{LN}} \quad I_3 = 148.039 \cdot A$$

$$I_1 + I_2 + I_3 = 377.909 \cdot A \neq I_G = 293.507 \cdot A$$