

A Nyquist plot is essentially a polar Bode plot. Like a Bode plot, it is plotted for the Open-Loop (OL) Transfer function and will give information about the stability of the Closed-Loop (CL) system.

Open-Loop (OL) Transfer function: $G(s) = \frac{N_{G(s)}}{D_{G(s)}}$ $m = \text{number of zeros}$
 $n = \text{number of poles}$

Basic Nyquist Rules

1. "Clean up" any "-s" terms in G(s) by multiplying by -1 as needed.
 If a "-" remains in G(s), the Nyquist plot will be mirrored about the imaginary axis. (rare)

2. Start at G(0), the DC gain, a point on the real axis.

If G(s) has a zero at the origin: $G(0) = 0$

If G(s) has a pole at the origin: $G(0) = \pm \infty$

Check initial phase angle as you would for a Bode plot.

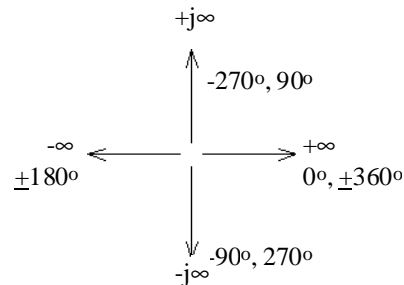

3. End at G(∞).

$n < m$ Plot $\rightarrow \infty$ almost always $+\infty$ (rare)

$n = m$ Plot $\rightarrow G(\infty)$, a point on the real axis

$n > m$ Plot $\rightarrow 0$ Angle of approach to origin = $(n - m) \cdot (-90 \cdot \text{deg})$
 (most common)

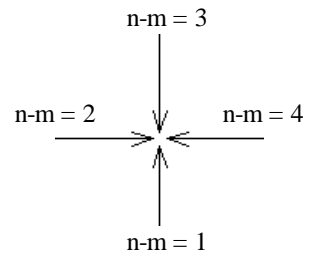

4. Plot the rest of the frequency response of G(s). It may help to start with Bode plots.
5. The $\omega < 0$ curve (dashed line) is simply the mirror image of the $\omega > 0$ curve about the real axis. This part of the curve is usually not necessary, it doesn't provide any more information.
6. Gain, k, makes entire plot grow in all directions (or shrink if $k < 1$).

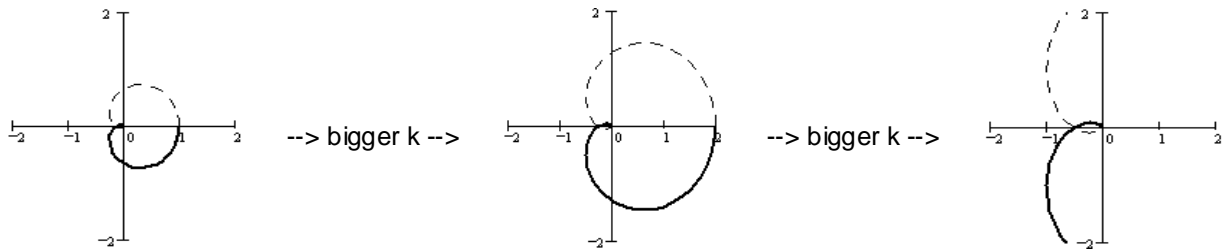

7. $Z = N + P$

P = OL poles in RHP (0 if open-loop stable)

N = CW encirclements of -1, CCW encirclements are counted as negative and may make up for P.

Z = CL poles in RHP (must be zero (or ≤ 0) if closed-loop stable)

8. ANY CW encirclements means Closed-Loop system is UNSTABLE

$N > 0 \rightarrow$ CL unstable

ECE 3510 Nyquist Plot Notes p.2

Counting Clockwise Encirclements

N = CW encirclements of -1,
 CCW encirclements are counted as negative and may make up for P .

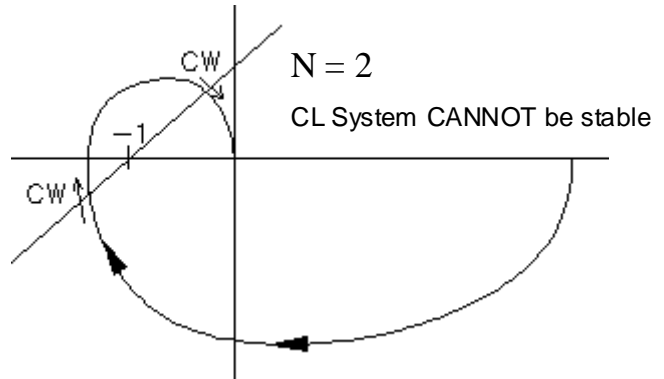
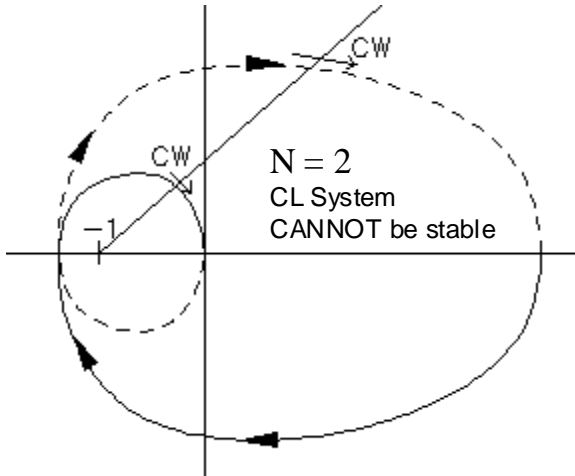
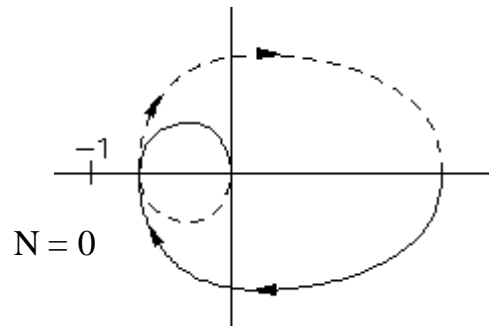

If you have the $\omega < 0$ curve (dashed line), then you can use any single-ended line that starts at -1 to help you count encirclements.

If you don't have the $\omega < 0$ curve (dashed line), then make your line extend both directions from -1.

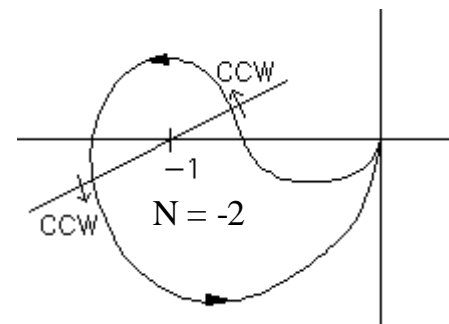
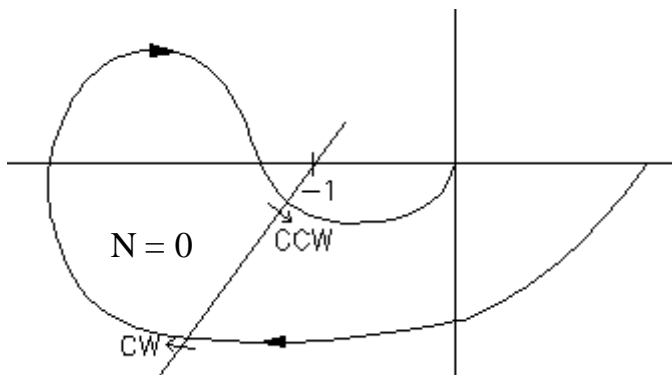
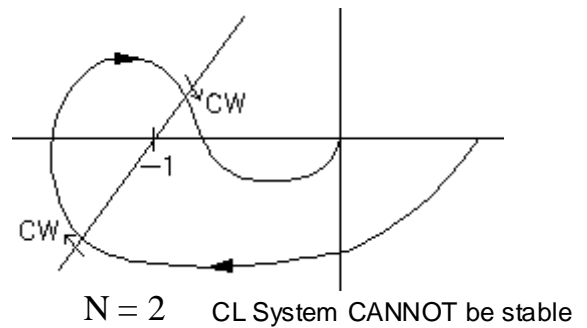
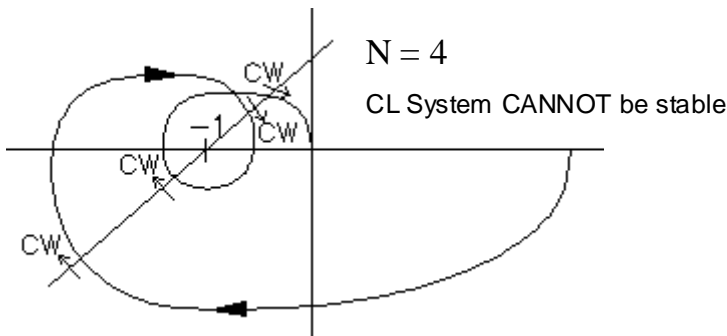

CCW encirclements are counted as negative.

CL System CAN be stable, if $P \leq 2$

$-N$ can make up for $+P$. and stabilize an OL unstable system

$$Z = N + P$$

P = OL poles in RHP (0 if open-loop stable)

N = CW encirclements of -1. CL System CANNOT be stable if $N > 0$

Z = CL poles in RHP (must be zero (or ≤ 0) if closed-loop stable)

To find the Phase Margin (PM):

1. Find where the Nyquist plot crosses the unit circle. These crossings separate the unit circle into regions.
2. Decide which of these regions have unacceptable CW encirclements.
3. Determine what phase change would cause the -1 point to be an unacceptable region, usually $180^\circ - \text{crossing}$

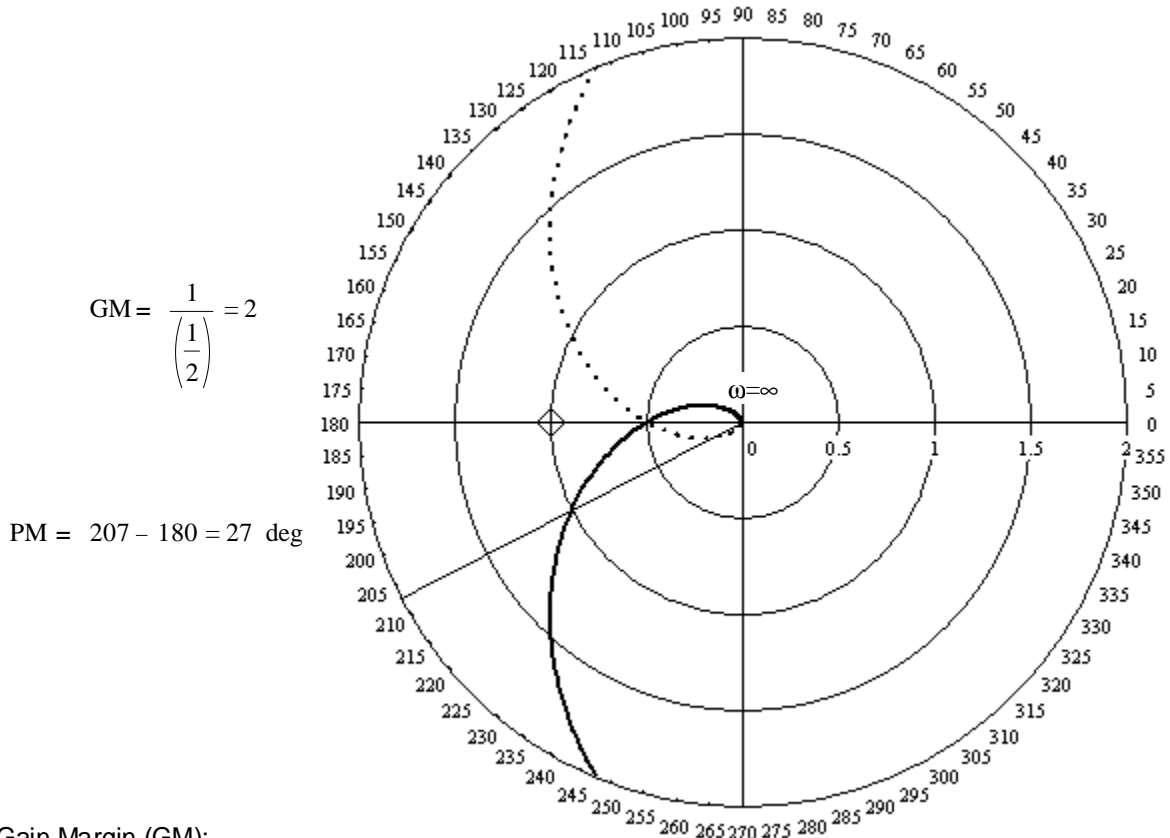

To find the Gain Margin (GM):

1. Find where the Nyquist plot crosses the negative real axis. These crossings separate the negative real axis into regions.
2. Decide which of these regions have unacceptable CW encirclements.
3. Determine what gain would cause the -1 point to be an unacceptable region, usually $\frac{1}{\text{crossing}}$ into the unacceptable region.
4. Usually there is just one upper limit of gain-- in that case report that as the Gain Margin.

5. If there is a lower limit of gain, report the Gain Margin as: $GM = \left[\text{Lower limit}, \text{upper limit} \right]$
 If there is no upper limit, then report it as ∞

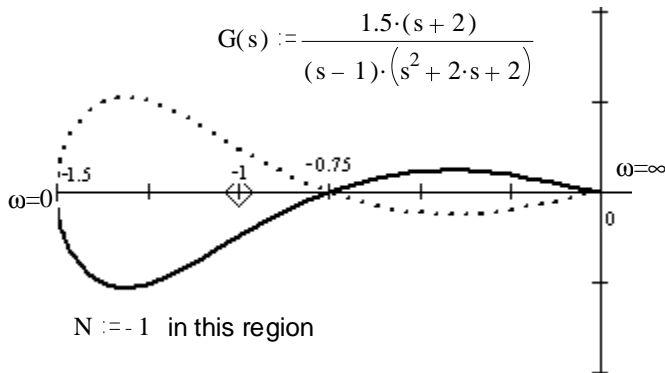

$P := 1$ For CL stability, $N := -1$ or more

$$GM = \left[\frac{1}{1.5}, \frac{1}{0.75} \right] = \left[0.667, 1.333 \right]$$

The normal contour

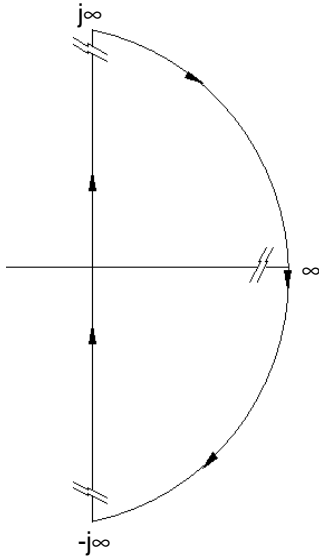

A pole on the imaginary axis causes a problem. Is it inside or outside of the contour?

Modify the contour to exclude the problematic pole.

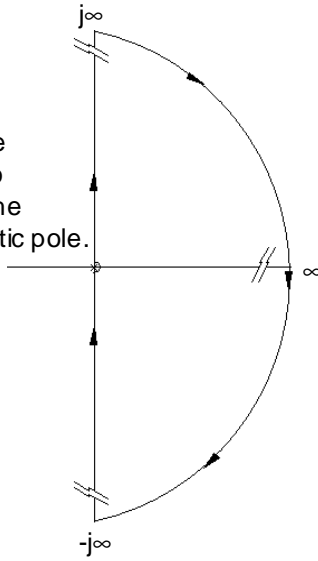

A single pole at the origin

A closer look

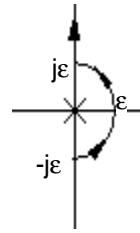

The Nyquist plot of this

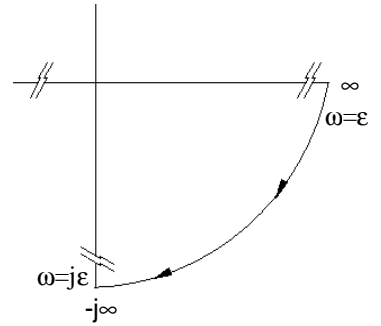

A double pole at the origin

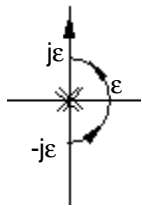

The Nyquist plot

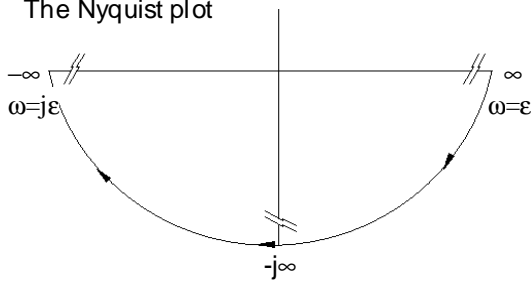

A triple pole at the origin

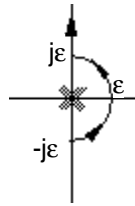

The Nyquist plot

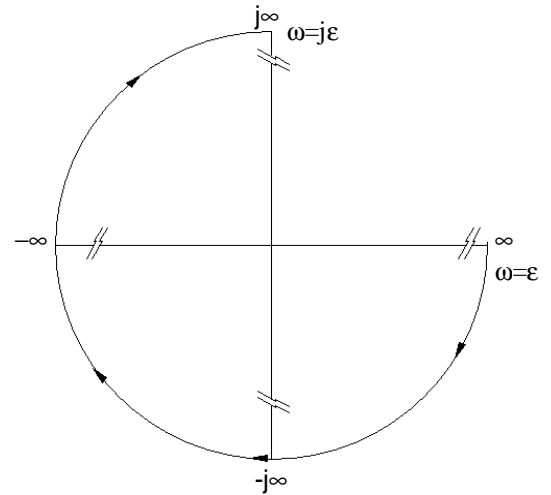

Poles at other locations on the imaginary axis

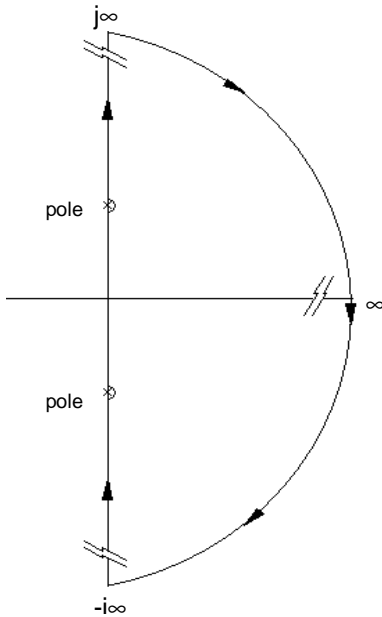

Possible Nyquist plots

