

Implementation (Physical Realization) of Feedback System Components and Compensators

- Design an instrumentation amplifier with a variable gain from approximately 1 to 40. This could be used as the summing (difference) block and the gain block of a feedback loop.

Your answer should use different values than my answer below.

- Design an active circuit which could follow the circuit you just designed and implement the PID compensator of Example 9.5 in the Nise textbook.

Note: your capacitor values may come out overly large due to the artificially small poles and zeroes.

Your answer should use different values than my answer below.

Answers

Your answers should use different values than my answers.

1.

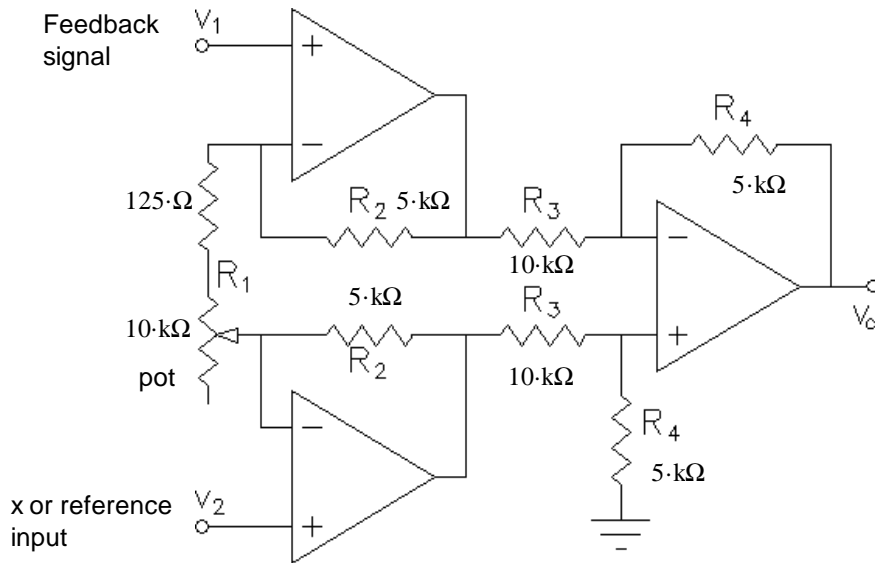

2.

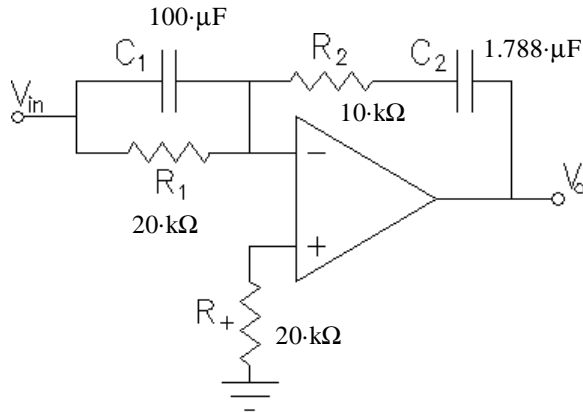

And either swap the inputs to the Instrumentation amplifier or follow this with a unity gain inverting amplifier.