

Use the current-force analogy discussed in class for the following problems.

1. a) Find the equivalent electric circuit for the mechanical system shown. F_{in} is an input.

b) Find the transfer function for the system. Put it in the standard form.

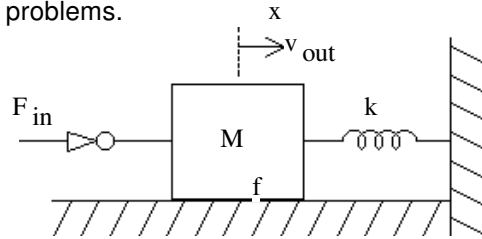

c) Check the units of all coefficients of the transfer function to make sure they agree and work out to the units of velocity over force. Recall that the units of $s = \frac{1}{\text{sec}}$

d) The resonant frequency of an electrical circuit can be found from $\frac{1}{\sqrt{L \cdot C}}$. What is it for this system?

e) Find the transfer function for the system. Where x is the displacement of the mass rather than its velocity. Put it in the standard form.

2. Find the equivalent electric circuit for the mechanical system shown. $u(t)$ is an input. Show x -velocity and q -velocity on the circuit.

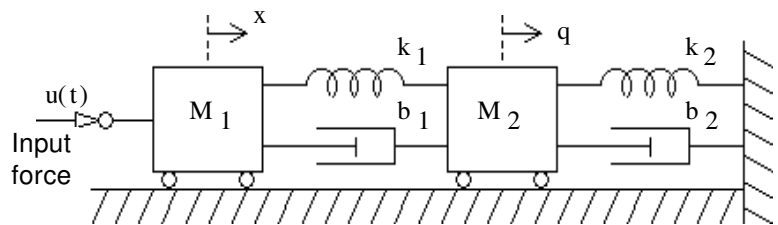

3. Find the equivalent electric circuit for the mechanical system shown. $r(t)$ is an input. Show v_1 & v_2 on the circuit.

4. Find the equivalent electric circuit for the levitated rocket sled shown. The rocket is a force input. There is no friction between the sled and guide rail, but there is air resistance (which can be modeled in exactly the same way as friction between the sled and guide rail) The accelerometer is firmly mounted onto the sled. Show x -velocity and y -velocity on the circuit.

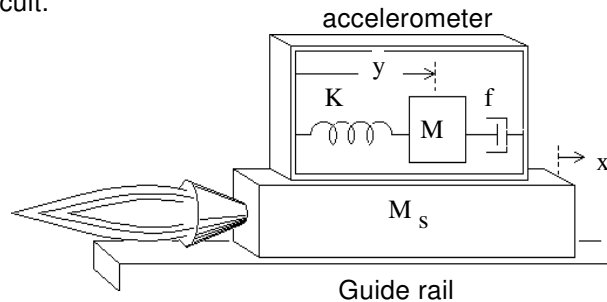
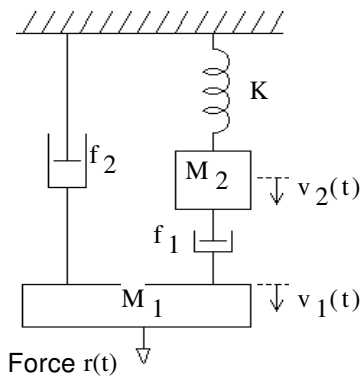

Answers

