

# ECE 3510 Root Locus Examples continued (Additional rules)

A. Stolp  
2/27/11,  
2/25/24

10. The breakaway (and arrival) points are solutions to:

$$\sum_{\text{all}} \frac{1}{(s + p_i)} = \sum_{\text{all}} \frac{1}{(s + z_i)}$$

Solve:  $\frac{1}{s+5} + \frac{1}{s-1} = \frac{1}{s+8} + \frac{1}{s+10}$

$$\frac{(s-1) + (s+5)}{(s+5) \cdot (s-1)} = \frac{(s+8) + (s+10)}{(s+8) \cdot (s+10)}$$

$$\frac{2 \cdot s + 4}{s^2 + 4 \cdot s - 5} = \frac{2 \cdot s + 18}{s^2 + 18 \cdot s + 80}$$

$$(2 \cdot s + 4) \cdot (s^2 + 18 \cdot s + 80) = (2 \cdot s + 18) \cdot (s^2 + 4 \cdot s - 5)$$

$$2 \cdot s^3 + 40 \cdot s^2 + 232 \cdot s + 320 = 2 \cdot s^3 + 26 \cdot s^2 + 62 \cdot s - 90$$

$$40 \cdot s^2 + 232 \cdot s + 320 = 26 \cdot s^2 + 62 \cdot s - 90$$

$$14 \cdot s^2 + 170 \cdot s + 410 = 0$$

$$\frac{-170 - \sqrt{170^2 - 4 \cdot 14 \cdot 410}}{2 \cdot 14} = -8.824$$

$$\frac{-170 + \sqrt{170^2 - 4 \cdot 14 \cdot 410}}{2 \cdot 14} = -3.319$$

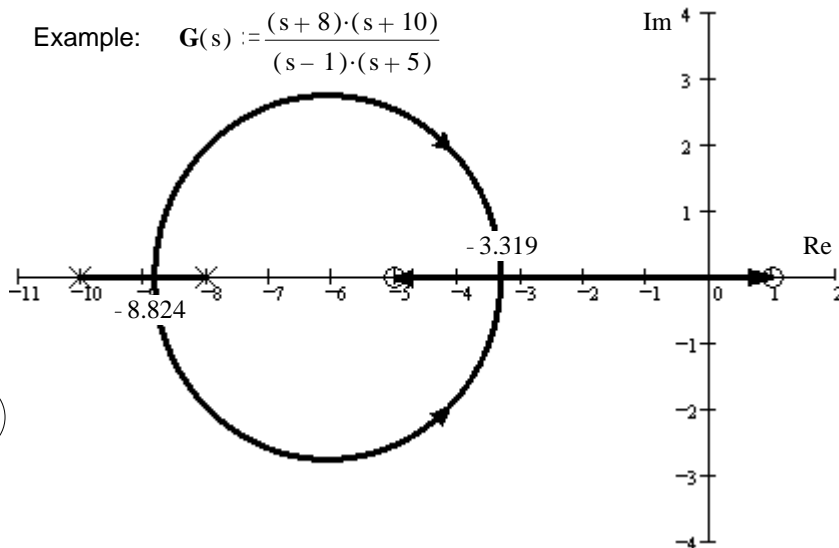

Breakaway (and arrival) points from the real axis ( $\sigma_b$ ) are also the solutions to:  $\frac{d}{ds} G(s) = 0$  where  $s$  is a real number (on the real axis)

Why? Because gain =  $k = -\frac{1}{G(s)}$  The breakaway point will be the point between -5 and +1 with the highest gain.

That is also the point with the lowest  $G(s)$  and highest  $-G(s)$ . Either way  $\frac{d}{ds} G(s)$

Make some plots  $s := -4, -3.99 \dots 0$

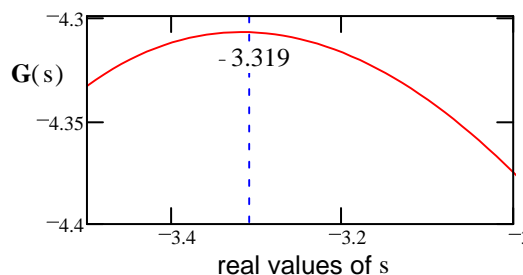
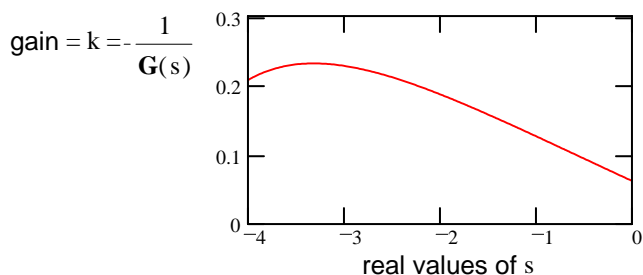

The breakin point will be the point between -10 and -8 with the lowest gain.

Make some plots  $s := -9.9, -9.893 \dots -8.1$

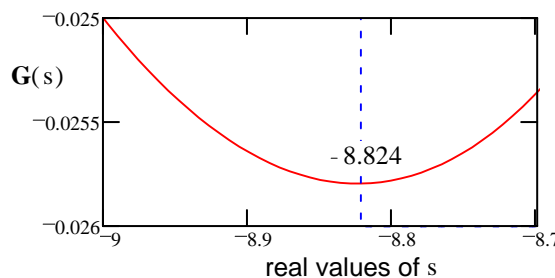
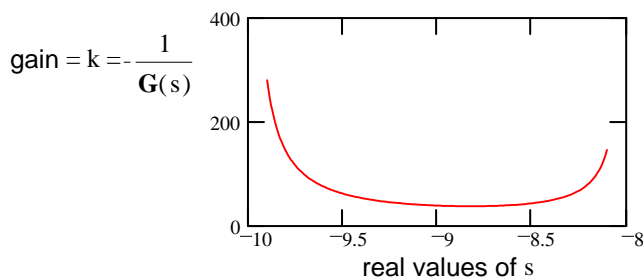



## Root Locus Examples, continued p3

### Find the Break-in points for Basic Root Locus Examples, Example 7

$$7. G(s) = \frac{(s+5) \cdot (s+8)}{s^2 - 6 \cdot s + 13}$$

$$\text{Break-away points } \frac{1}{(s+5)} + \frac{1}{(s+8)} = \frac{1}{s-3-2j} + \frac{1}{s-3+2j} = \frac{2 \cdot s - 6}{s^2 - 6 \cdot s + 13} \quad \text{NOT } \frac{1}{s^2 - 6 \cdot s + 13}$$

Note the way these poles are expressed

Guess -6.3 Use this guess in all but the closest poles and zeroes

$$\frac{1}{s-3-2j} + \frac{1}{s-3+2j} - \frac{2 \cdot (-6.3) - 6}{s^2 - 6 \cdot (-6.3) + 13} = 0 \quad \text{Solutions: } \begin{pmatrix} 2.57 \\ -6.3 \end{pmatrix} \text{ guess was good}$$

### Find the Departure angles from complex poles for Basic Root Locus Examples, Example 7

$$\text{atan}\left(\frac{2}{8+3}\right) = 10.305 \cdot \text{deg}$$

$$\text{atan}\left(\frac{2}{5+3}\right) = 14.036 \cdot \text{deg}$$

$$\text{atan}\left(\frac{2}{8+3}\right) + \text{atan}\left(\frac{2}{5+3}\right) - 90 \cdot \text{deg} - \theta = \pm 180^\circ$$

$$\text{atan}\left(\frac{2}{8+3}\right) + \text{atan}\left(\frac{2}{5+3}\right) - 90 \cdot \text{deg} - 180 \cdot \text{deg} = -245.659 \cdot \text{deg}$$

$$\text{atan}\left(\frac{2}{8+3}\right) + \text{atan}\left(\frac{2}{5+3}\right) - 90 \cdot \text{deg} + 180 \cdot \text{deg} = 114.341 \cdot \text{deg}$$

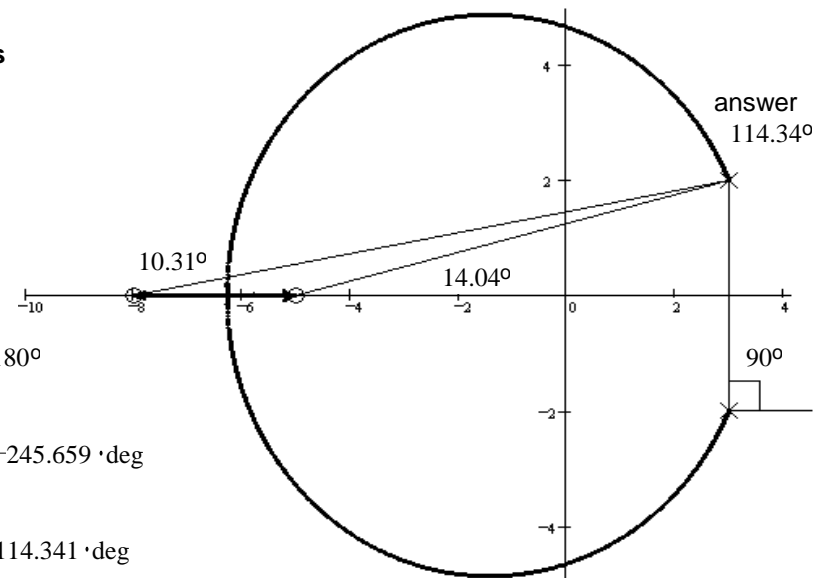

better answer

### Finding the $j\omega$ crossing point using rule 9:

$$G(s) := \frac{(s+5) \cdot (s+8)}{s^2 - 6 \cdot s + 13}$$

$$\text{Try: } s := 5 \cdot j \quad \angle G(s) = \arg(G(5 \cdot j)) = -171.193 \cdot \text{deg}$$

$$\text{Try: } s := 4.5 \cdot j \quad \angle G(s) = \arg(G(s)) = 176.375 \cdot \text{deg} \quad \arg(G(s)) - 360 \cdot \text{deg} = -183.625 \cdot \text{deg}$$

$$\text{linear interpolation } 4.5 + \frac{183.625 - 180}{183.625 - 171.193} \cdot (5 - 4.5) = 4.646$$

$$\text{Try: } s := 4.646 \cdot j \quad \angle G(s) = \arg(G(s)) = -179.838 \cdot \text{deg}$$

$$\text{linear interpolation } 4.5 + \frac{183.625 - 180}{183.625 - 179.838} \cdot (4.646 - 4.5) = 4.64$$

$$\text{Try: } s := 4.64 \cdot j \quad \angle G(s) = \arg(G(s)) = -179.991 \cdot \text{deg} \quad \text{close enough}$$

### Finding the $j\omega$ crossing gain using rule 8:

$$\text{Gain: } \frac{1}{|G(s)|} = \frac{(4.64 \cdot j)^2 - 6 \cdot (4.64 \cdot j) + 13}{(4.64 \cdot j + 5) \cdot (4.64 \cdot j + 8)} = \frac{\sqrt{[13 - (4.64)^2]^2 + (6 \cdot (4.64))^2}}{\sqrt{4.64^2 + 5^2} \cdot \sqrt{4.64^2 + 8^2}} = 0.462 \quad \text{to be stable: } k > 0.462$$

## Root Locus Examples, continued p3



# ECE 3510 Root Locus Departure and Arrival Angles

$$G(s) := \frac{1}{(s^2 + 4s + 13) \cdot (s+1) \cdot (s+5)} = \frac{1}{(s+2+3j) \cdot (s+2-3j) \cdot (s+1) \cdot (s+5)}$$

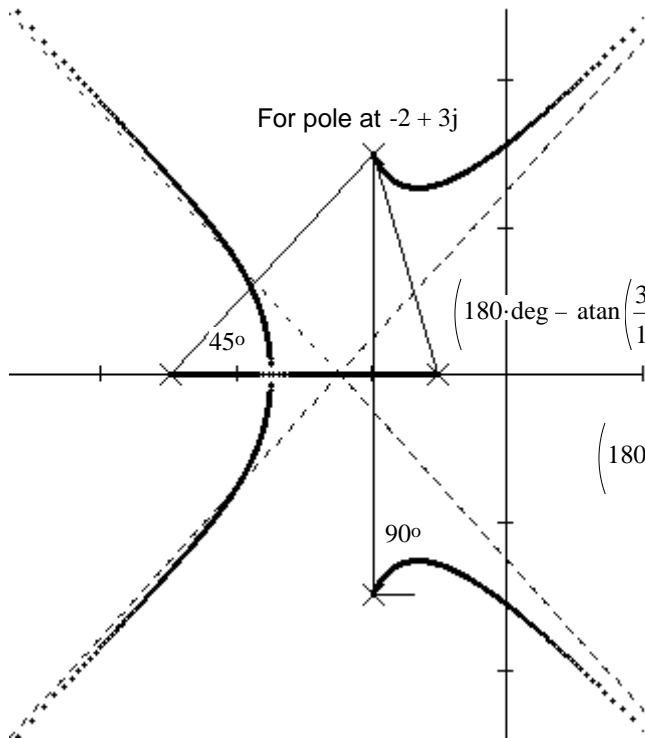

$$s := -2 + 3j$$

$$\frac{1}{(s+2+3j) \cdot (s+1) \cdot (s+5)} = -5.5556 \cdot 10^{-3} + 0.0111i$$

$$180\text{-deg} - \arg(-5.5556 \cdot 10^{-3} + 0.0111i) = 63.412 \cdot \text{deg}$$

If you leave out  $180^\circ$  (not recommended)

$$\left(-\operatorname{atan}\left(\frac{3}{1}\right)\right) + 90\text{-deg} + 45\text{-deg} = 63.435 \cdot \text{deg} + \theta = 0^\circ, \pm 360^\circ$$

$$\theta = -63.435\text{-deg}$$

$$G(s) := \frac{s+7}{(s^2 + 4s + 13) \cdot (s+1) \cdot (s+5)}$$

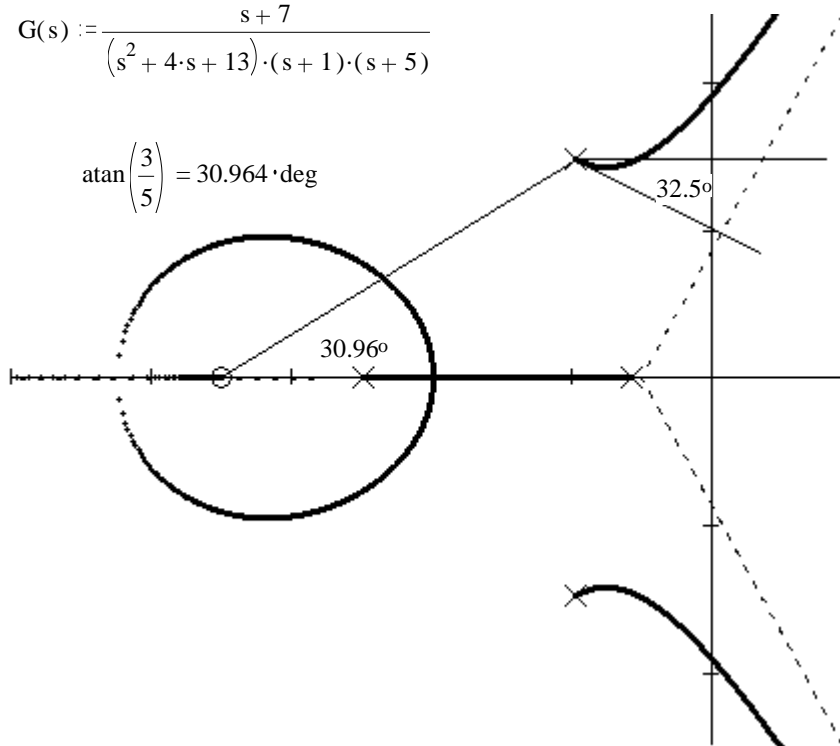

$$s := -2 + 3j$$

$$\frac{s+7}{(s+2+3j) \cdot (s+1) \cdot (s+5)} = -0.0611 + 0.0389i$$

$$180\text{-deg} - \arg(-0.0611 + 0.0389i) = 32.483 \cdot \text{deg}$$

$$\left(180\text{-deg} - \operatorname{atan}\left(\frac{3}{1}\right)\right) + 90\text{-deg} + 45\text{-deg} - \operatorname{atan}\left(\frac{3}{5}\right) = 212.471 \cdot \text{deg} + \theta = \pm 180^\circ$$

$$180 - 212.5 = -32.5 \text{ deg}$$

# ECE 3510 Root Locus Departure and Arrival Angles p2

$$G(s) := \frac{s^2 - 2 \cdot s + 2}{(s^2 + 4 \cdot s + 13) \cdot (s + 1) \cdot (s + 5)}$$

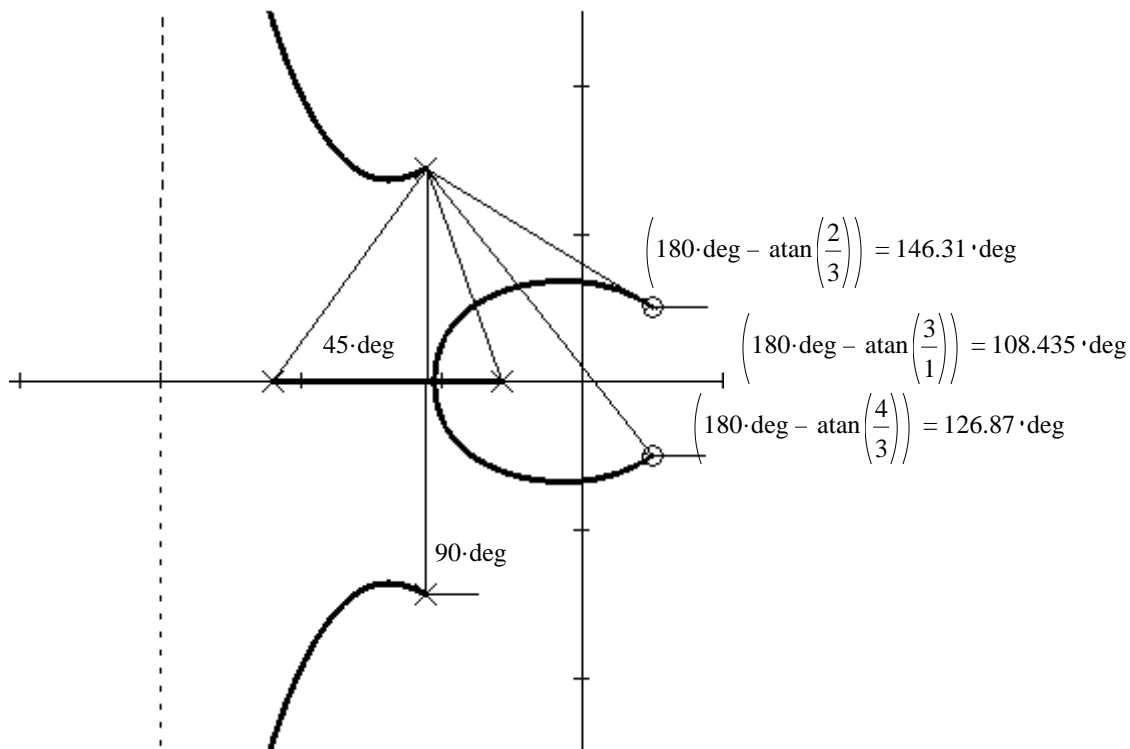

$$\left(180\text{-deg} - \operatorname{atan}\left(\frac{3}{1}\right)\right) + 90\text{-deg} + 45\text{-deg} - \left(180\text{-deg} - \operatorname{atan}\left(\frac{2}{3}\right)\right) - \left(180\text{-deg} - \operatorname{atan}\left(\frac{4}{3}\right)\right) = -29.745 \text{ deg} + \theta = \pm 180^\circ$$

$$-(180 - 29.75) = -150.25 \text{ deg}$$

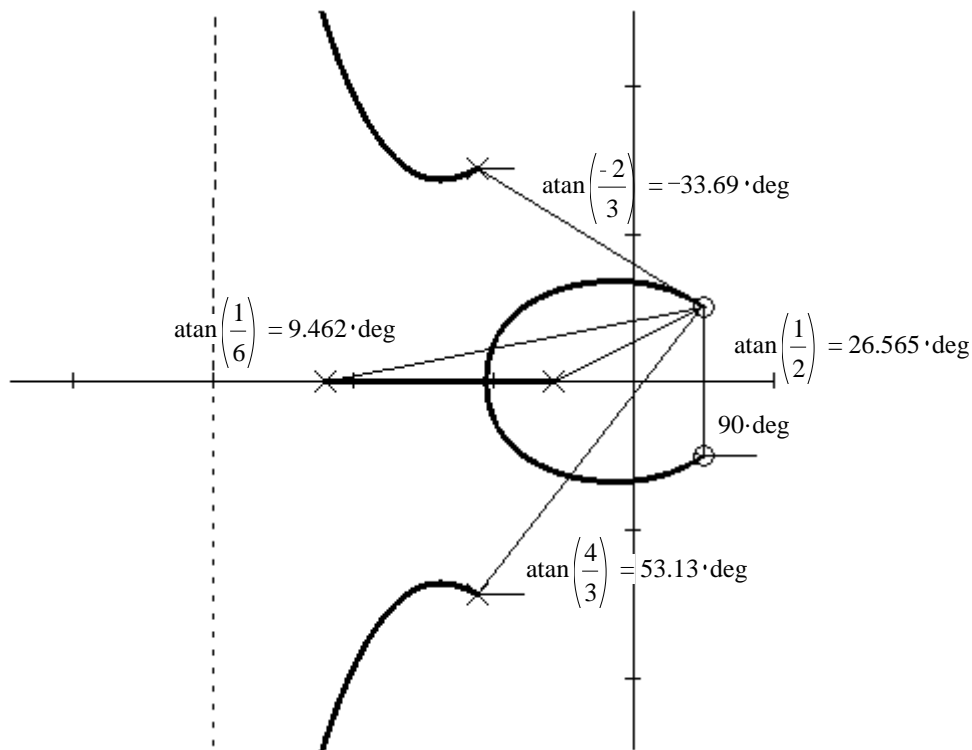

$$\operatorname{atan}\left(\frac{1}{2}\right) + \operatorname{atan}\left(\frac{-2}{3}\right) + \operatorname{atan}\left(\frac{1}{6}\right) + \operatorname{atan}\left(\frac{4}{3}\right) - 90\text{-deg} = -34.533 \text{ deg} \quad -\theta = \pm 180^\circ$$

$$(180 - 34.5) = 145.5 \text{ deg}$$

# ECE 3510 Root Locus Design Examples

Recall the simple crude servo from lab 1

$$G(s) := \frac{1643}{s \cdot (s + 16.64) \cdot (s + 53.78)}$$

$$\sigma = \frac{-0 - 16.64 - 53.78}{3} = -23.473$$

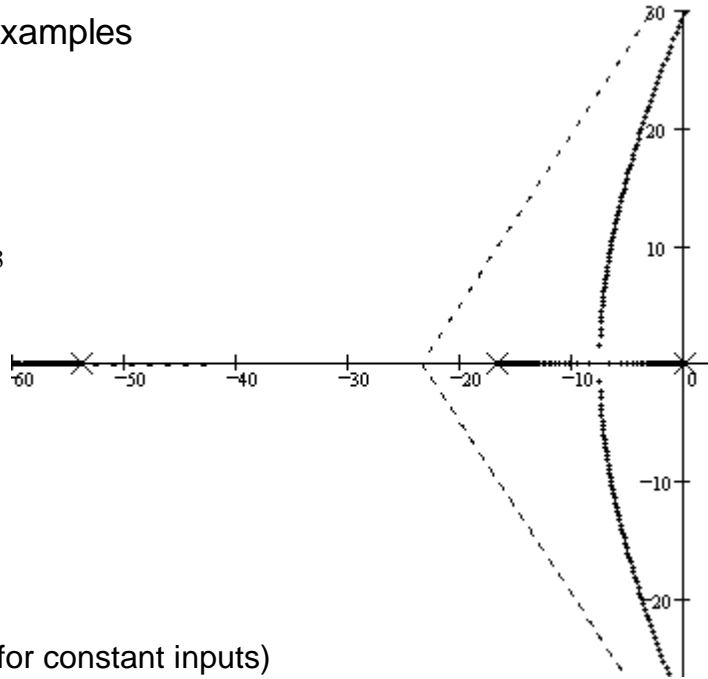

**PI** To eliminate steady-state error (for constant inputs) & perfect rejection of constant disturbances

Note: The DC motor has a pole at zero and should do zero the steady-state error by itself, but nonlinearities prevent it from doing it well.

$$G_c(s) := \frac{1643}{s \cdot (s + 16.64) \cdot (s + 53.78)} \cdot \frac{s + 0.1}{s} \quad \text{Add pole at 0 and zero at -0.1}$$

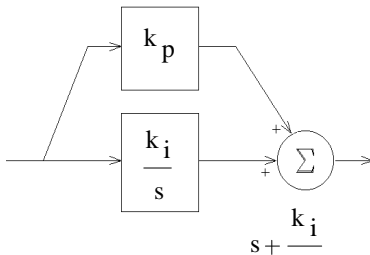

$$C(s) = k_p + \frac{k_i}{s} = k_p \cdot \frac{s + \frac{k_i}{k_p}}{s}$$

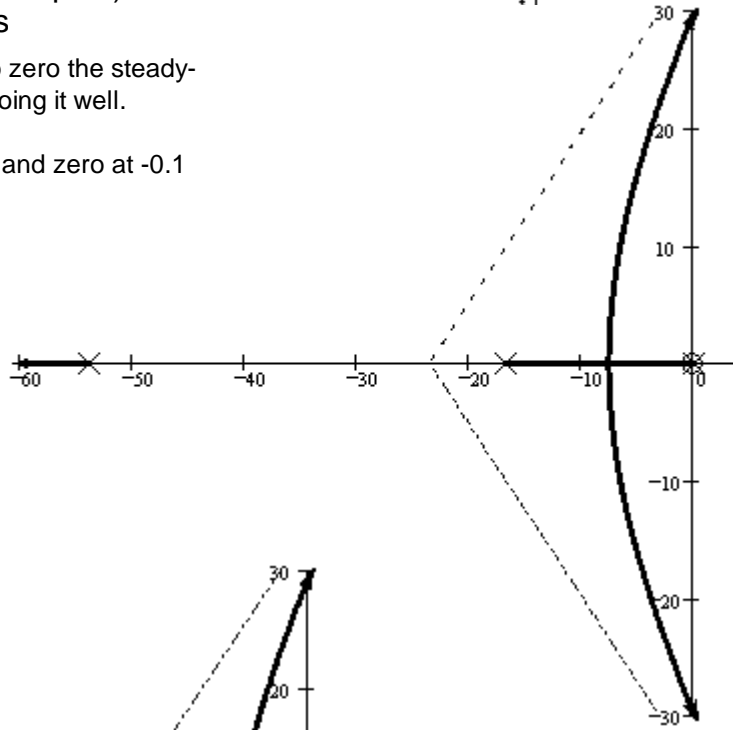

**LAG** An alternative is a Lag Compensator, here with a pole at -0.1 and a zero at -0.5

$$G_c(s) = \frac{1643}{s \cdot (s + 16.64) \cdot (s + 53.78)} \cdot \frac{s + 0.5}{s + 0.1}$$

This works very much like the PI controller, but without the need for active components.

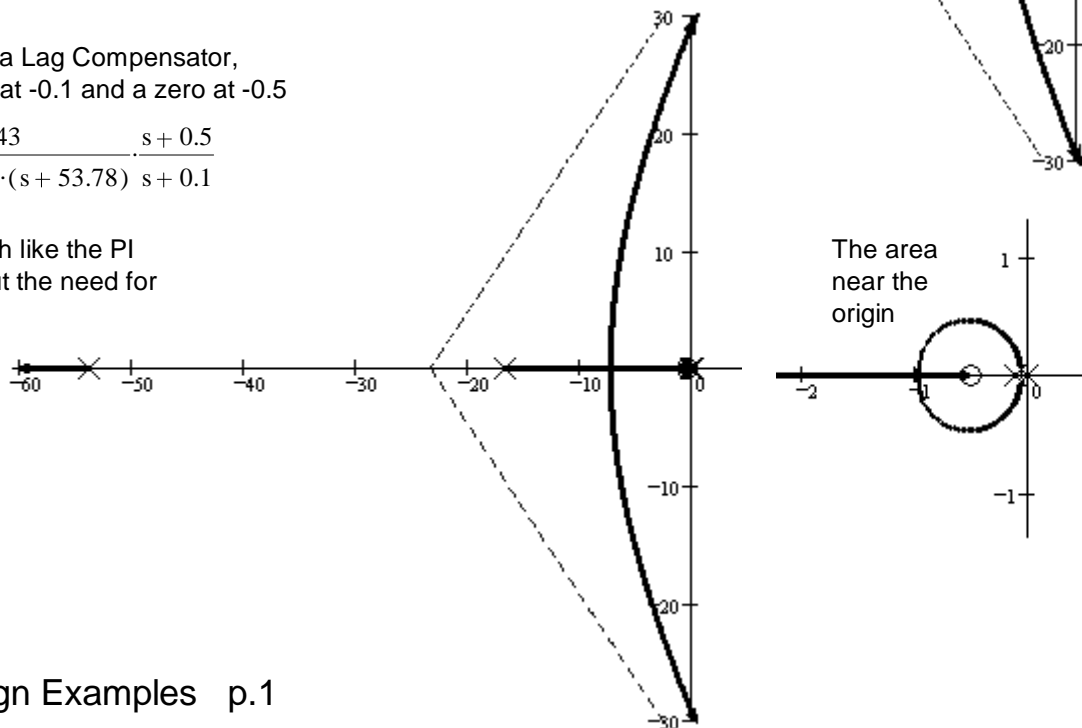

## Root Locus Design Example p.2

Let's keep the pole at 0 and zero at -0.1 for elimination of steady-state errors and rejection of disturbances

$$\text{CL poles at } p := -7.06 + 7.06j \quad k = \frac{1}{|G(-7.06 + 7.06j)|} = 3.417$$

$$\text{and } -7.06 - 7.06j$$

At gain of 3.44

$$\text{atan}\left(\frac{\text{Im}(p)}{\text{Re}(p) + 53.78}\right) = 8.593 \cdot \text{deg}$$

$$\text{atan}\left(\frac{\text{Im}(p)}{\text{Re}(p) + 16.64}\right) = 36.388 \cdot \text{deg}$$

This is a point in the root locus because:

$$-8.6 \cdot \text{deg} - 36.4 \cdot \text{deg} - 135 \cdot \text{deg} - 135 \cdot \text{deg} + 135 \cdot \text{deg} = -180 \cdot \text{deg}$$

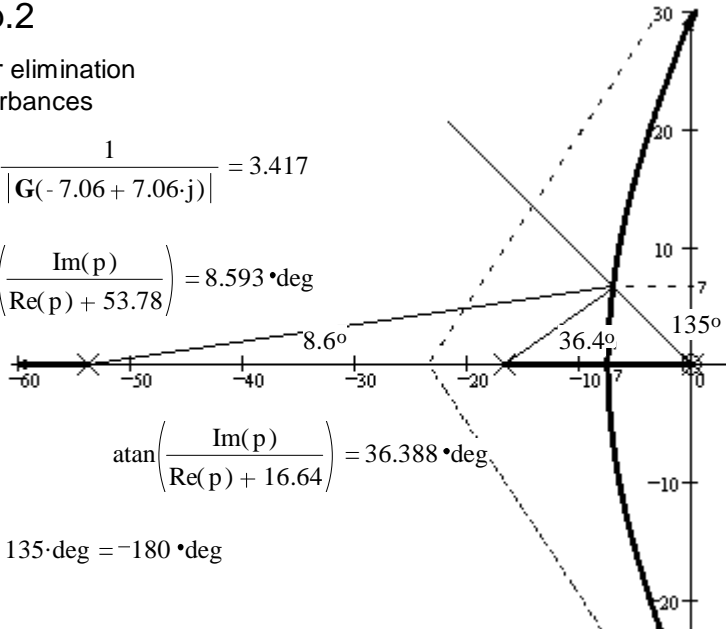

## PD or PID To Improve the dynamic response

Want to double the speed

Want poles to move to:  $p := -14 + 14j$   
 $-14 - 14j$

$$\text{atan}\left(\frac{\text{Im}(p)}{\text{Re}(p) + 53.78}\right) = 19.389 \cdot \text{deg}$$

$$\text{atan}\left(\frac{\text{Im}(p)}{\text{Re}(p) + 16.64}\right) = 79.321 \cdot \text{deg}$$

Unfortunately, this point is NOT on the root locus

$$-\text{atan}\left(\frac{\text{Im}(p)}{\text{Re}(p) + 53.78}\right) - \text{atan}\left(\frac{\text{Im}(p)}{\text{Re}(p) + 16.64}\right) - 135 \cdot \text{deg} = -233.71 \cdot \text{deg}$$

Maybe we could add a zero so that its angle is:

$$\theta_z := 233.71 \cdot \text{deg} - 180 \cdot \text{deg} \quad \theta_z = 53.71 \cdot \text{deg}$$

$$x = \text{Im}(p) \cdot \frac{1}{\tan(\theta_z)} = 10.28$$

$$z := \text{Re}(p) - \text{Im}(p) \cdot \frac{1}{\tan(\theta_z)}$$

$$z = -24.28$$

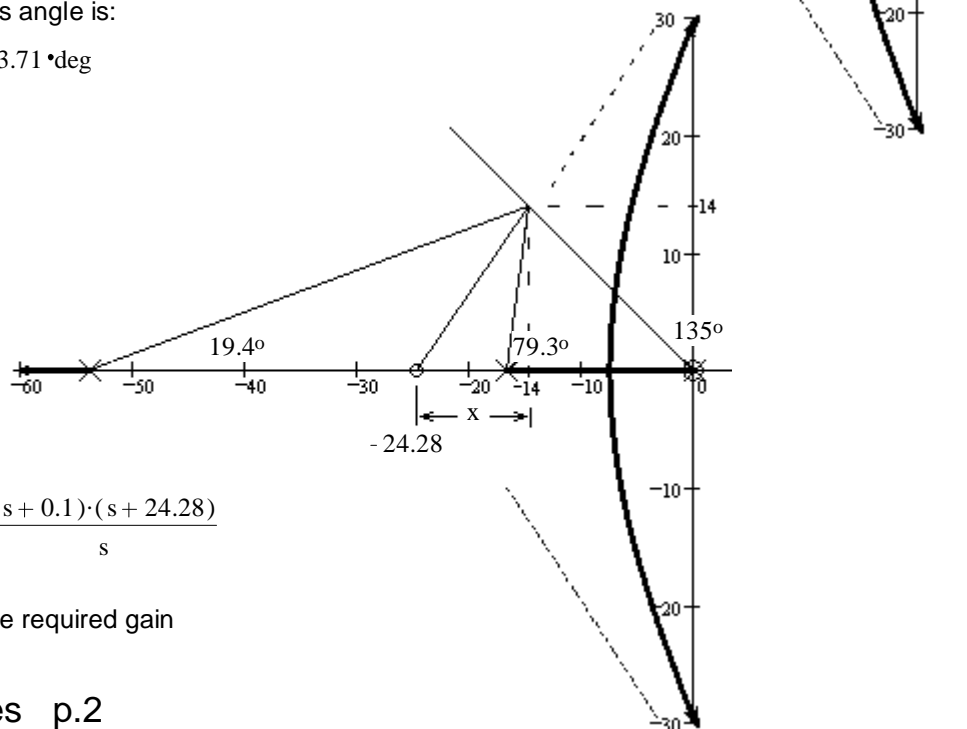

$$G_c(s) := \frac{1643}{s \cdot (s + 16.64) \cdot (s + 53.78)} \cdot \frac{(s + 0.1) \cdot (s + 24.28)}{s}$$

$$k = \frac{1}{|G(-14 + 14j)|} = 7.24 \quad \text{is the required gain}$$

## Root Locus Design Examples p.2



# Root Locus Design Examples p.3

We have designed a our compensation with the following:

- A pole at the origin
- A zero at -0.1
- A zero at -24.28
- Gain of 0.418

Find the  $k_p$ ,  $k_i$ , &  $k_d$  of a PID controller.

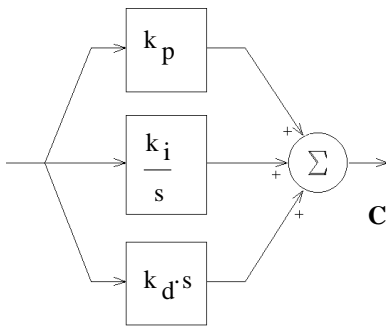

$$C(s) = k_p + \frac{k_i}{s} + s \cdot k_d = \frac{s \cdot k_p + k_i + s^2 \cdot k_d}{s}$$

$$= \frac{s^2 + \frac{k_p}{k_d} \cdot s + \frac{k_i}{k_d}}{s} = k_d \cdot \frac{s^2 + \frac{k_p}{k_d} \cdot s + \frac{k_i}{k_d}}{s}$$

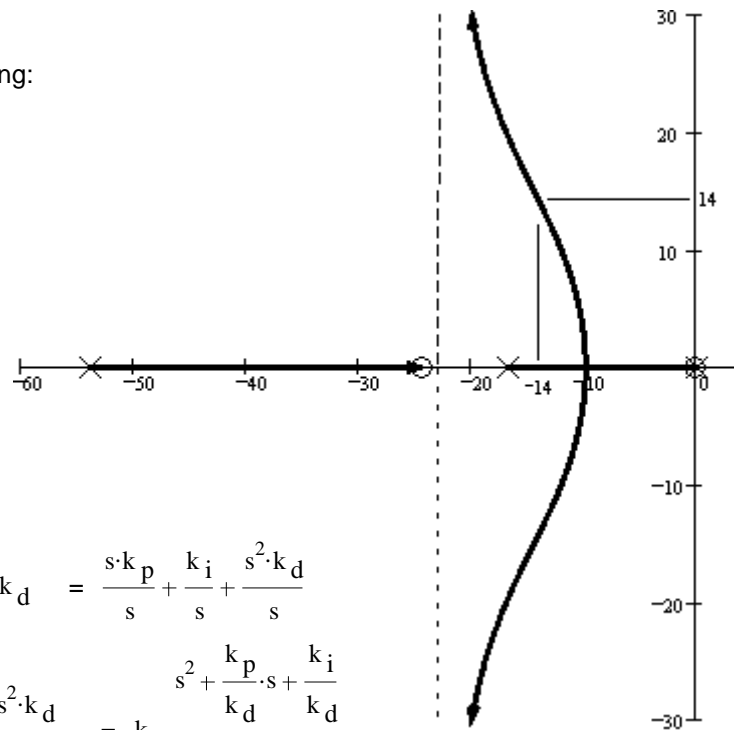

gain =  $k_d := 0.418$

$$(s + 0.1) \cdot (s + 24.28) = s^2 + 24.38 \cdot s + 2.43$$

$$= s^2 + \frac{k_p}{k_d} \cdot s + \frac{k_i}{k_d}$$

$$\frac{k_i}{k_d} = 2.43 \quad k_i := k_d \cdot 2.43 \quad k_i = 1.016$$

$$\frac{k_p}{k_d} = 24.38 \quad k_p := k_d \cdot 24.38 \quad k_p = 10.191 \quad \text{Notice: } \frac{k_i}{k_p} = 0.1 \approx 0.1$$

Notice that the proportional gain is actually almost 3 times higher than it was before.  $3 \cdot 3.44 = 10.32$

## LEAD An alternative to the differentiator is a Lead Compensator.

Instead of a single zero with:  $\theta_z = 53.71 \cdot \text{deg}$

How about a zero with  $\theta_z := 70 \cdot \text{deg}$  And a pole with  $\theta_p := 70 \cdot \text{deg} - 53.71 \cdot \text{deg}$

$$x = \text{Im}(p) \cdot \frac{1}{\tan(\theta_z)} = 5.096$$

$$z := \text{Re}(p) - \text{Im}(p) \cdot \frac{1}{\tan(\theta_z)} \quad z = -19.096$$

$$x_p = \text{Im}(p) \cdot \frac{1}{\tan(\theta_p)} = 47.907$$

$$p := \text{Re}(p) - \text{Im}(p) \cdot \frac{1}{\tan(\theta_p)} \quad p = -61.907$$

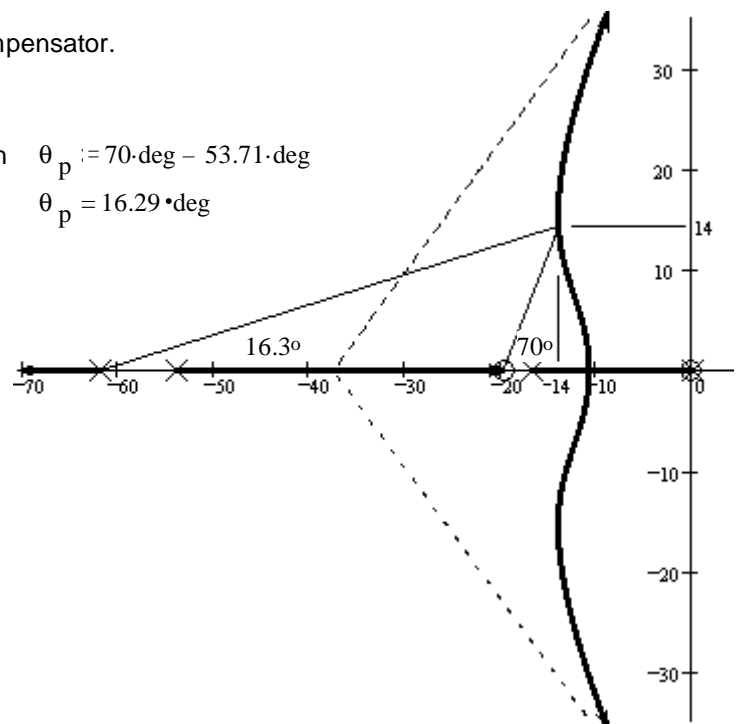

This example is actually a PI-Lead controller

**Problems with the differentiator**

1. Tries to differentiate a step input into an impulse -- not likely.  
You'll have to consider how your differentiator will actually handle a step input and how your amplifier will saturate.  
If the differentiator and amplifiers saturate in such a way the the "area under the curve" approximates the impulse "area under the curve", then this may not be such a problem. It may not be as fast as predicted from the linear model, but it may be as fast as the system limits allow. (Pedal-to-the-metal.)
2. It's a high-pass filter and can accentuate noise.  
This is actually common to all compensators that speed up the response.
3. Requires active components and a power supply to build.  
Usually no big deal since your amplifier (source of gain) does too.
4. Is never perfect (always has higher-order poles), but then neither is anything else. Especially in mechanical systems, these poles usually are well beyond where they could cause problems.

Alternatives:

1. Lag-Lead or PI-Lead compensation. This eliminates the differentiator, but it is still a high-pass filter that can be a noise problem and it could still saturate the amplifier if the input changes too rapidly.  
Be sure to check for saturation problems.
2. Place the differentiator in the feedback loop. The output of the plant is much less likely to be a step or to change so rapidly that it causes problems.

Differentiation in the feedback

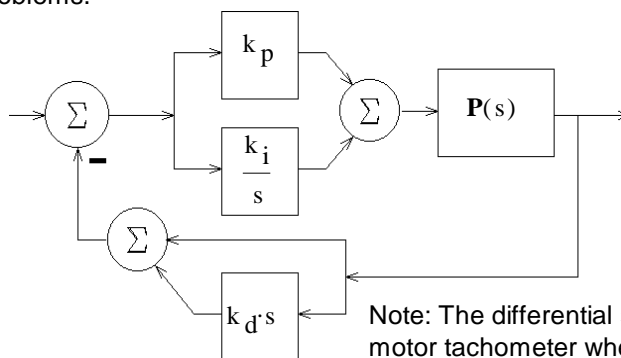

Find the  $k_p$ ,  $k_i$ , &  $k_d$  of this controller.

Note: The differential signal is often taken from a motor tachometer when the output is a position. Then you don't need a separate differentiator circuit, just a separate gain for that signal.

$$\begin{aligned}
 \mathbf{F(s) \cdot C(s)} &= \left( k_p + \frac{k_i}{s} \right) \cdot (1 + k_d \cdot s) = k_p \cdot k_d \cdot \left[ \frac{s + \frac{k_i}{k_p}}{s} \right] \cdot \left( \frac{1}{k_d} + s \right) = k_p \cdot k_d \cdot \frac{\left( s + \frac{k_i}{k_p} \right) \cdot \left( s + \frac{1}{k_d} \right)}{s} \\
 \mathbf{C(s)} \quad \mathbf{F(s)} & \qquad \qquad \qquad \text{For our example:} &= 0.418 \cdot \frac{(s + 0.1) \cdot (s + 24.28)}{s} \\
 & & k_d := \frac{1}{24.38} \quad k_d = 0.041 \\
 & & k_p := \frac{0.418}{k_d} \quad k_p = 10.191 \\
 & & k_i := k_p \cdot 0.1 \quad k_i = 1.019
 \end{aligned}$$

In this case the open-loop zero in the feedback loop IS NOT in the closed-loop. This turns out to make the step response slower than predicted by the second-order approximation, but try a simulation, you may be able to use significantly more gain with no more overshoot. The differentiator in this position inhibits overshoot.

# PI and PID Design Examples p.5

Ex.2, from S16 Exam 3 Consider the transfer function:

$$G(s) := \frac{s+5}{(s+1) \cdot (s^2+4s+20)}$$

a) Find the departure angle from a complex pole.

Angles:

from pole at -1  $\theta_{p1} := 180 \cdot \text{deg} - \text{atan}\left(\frac{4}{1}\right) \quad \theta_{p1} = 104.036 \cdot \text{deg}$

from pole at -2-4j  $\theta_{p2} := 90 \cdot \text{deg} \quad \theta_{p2} = 90 \cdot \text{deg}$

from zero at -5  $\theta_z := \text{atan}\left(\frac{4}{3}\right) \quad \theta_z = 53.13 \cdot \text{deg}$

$$\theta = 53.13 \cdot \text{deg} - 90 \cdot \text{deg} - 104.036 \cdot \text{deg} + 180 \cdot \text{deg} = 39.094 \cdot \text{deg}$$

b) Draw a root locus plot. Calculate the centroid and accurately draw the departure angle.

$$\sigma := \frac{5 - 1 - 2 - 2}{2} \quad \sigma = 0$$

c) Is there any decent place to locate the closed-loop poles? NO

d) You would like to place your closed-loop poles to get a settling time of 1/2 sec and 0.656% overshoot. Add the simplest possible compensator to accomplish this and calculate what the compensator should be.

2% settling time:  $T_s = \frac{4}{a} \quad a = \frac{4}{\left(\frac{1}{2}\right)} = 8$

Overshoot:  $OS = e^{-\frac{\pi \cdot a}{b}} \quad \%OS = 100\% \cdot e^{-\frac{\pi \cdot a}{b}}$

$$\frac{a}{b} = \frac{\ln(OS)}{-\pi} = \frac{\ln(0.00656)}{-\pi} = 1.6 \quad b = \frac{8}{1.6} = 5$$

Pole should be at -8 + 5j

Angles:

from pole at -1  $180 \cdot \text{deg} - \text{atan}\left(\frac{5}{7}\right) = 144.462 \cdot \text{deg}$

from pole at -2+4j  $180 \cdot \text{deg} - \text{atan}\left(\frac{1}{6}\right) = 170.538 \cdot \text{deg}$

from pole at -2-4j  $180 \cdot \text{deg} - \text{atan}\left(\frac{9}{6}\right) = 123.69 \cdot \text{deg}$

from zero at -5  $180 \cdot \text{deg} - \text{atan}\left(\frac{5}{3}\right) = 120.964 \cdot \text{deg}$

$$144.462 \cdot \text{deg} + 170.538 \cdot \text{deg} + 123.69 \cdot \text{deg} - 120.964 \cdot \text{deg} = 317.726 \cdot \text{deg}$$

$$\theta_z := 317.726 \cdot \text{deg} - 180 \cdot \text{deg} \quad \theta_z = 137.726 \cdot \text{deg}$$

$$\tan(137.726 \cdot \text{deg} - 90 \cdot \text{deg}) = 1.1 = \frac{x}{5} \quad x := 5 \cdot 1.1 \quad 8 - x = 2.5 \quad C(s) = s + 2.5$$

$$G_c(s) := \frac{(s+5) \cdot (s+2.5)}{(s+1) \cdot (s^2+4s+20)} \quad s := -8 + 5j \quad \text{Check: } \arg\left[\frac{(s+5) \cdot (s+2.5)}{(s+1) \cdot (s^2+4s+20)}\right] = 180 \cdot \text{deg}$$

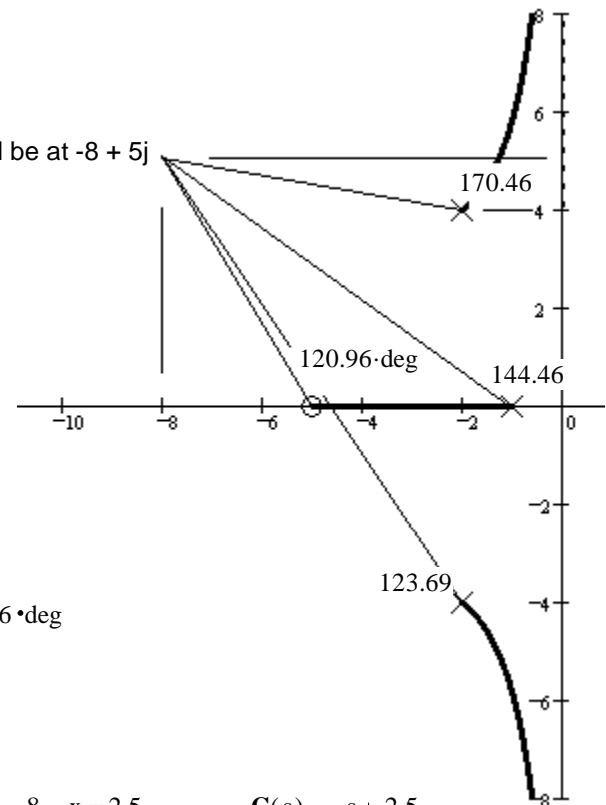
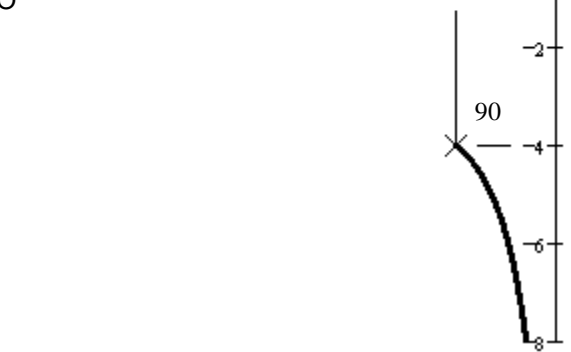
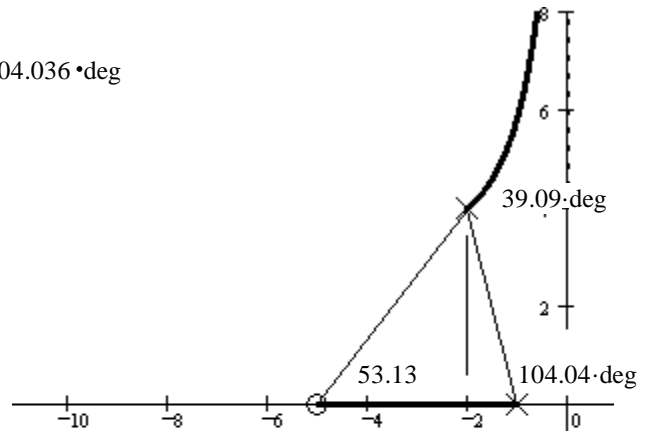

## PI and PID Design Examples p.6

e) What is the gain?  $k := \frac{1}{|G_c(s)|} = \left| \frac{(-8 + 5j + 1) \cdot [(-8 + 5j)^2 + 4 \cdot (-8 + 5j) + 20]}{(-8 + 5j + 5) \cdot (-8 + 5j + 2.5)} \right| = 13.059$

f) What is the steady-state error for a unit-step input?

$$G_c(s) := \frac{(s+5) \cdot (s+2.5)}{(s+1) \cdot (s^2 + 4s + 20)} \quad G_c(0) = \frac{(0+5) \cdot (0+2.5)}{(0+1) \cdot (0^2 + 4 \cdot 0 + 20)} = \frac{(5) \cdot (2.5)}{(1) \cdot (20)} = 0.625$$

$$G_c(0) = 0.625 \quad e_{\text{step}} = \frac{1}{1 + k \cdot 0.625} = 10.91\%$$

g) If this steady-state error was a little too big, what would be the very simplest way to reduce it?

turn up the gain

Ex.3, from S17 Exam 3

a) Sketch the root locus plot of,  $G(s) := \frac{100}{(s+25) \cdot (s+40) \cdot (s+70)}$   $m := 0$   
 $n := 3$

$$\sigma_C = \frac{-25 + -40 + -70}{n - m} = -45 \quad n - m = 3 \quad \text{so asymptotes are at } \pm 60^\circ \text{ \& } 180^\circ$$

The gain is set at 452, so that one of the closed-loop poles is at,  $s := -24.48 + 27.2j$

Further calculations yield:

Settling time: 0.163·sec

% overshoot: 5.92·%

Steady-state error to a unit-step input: 60.8%

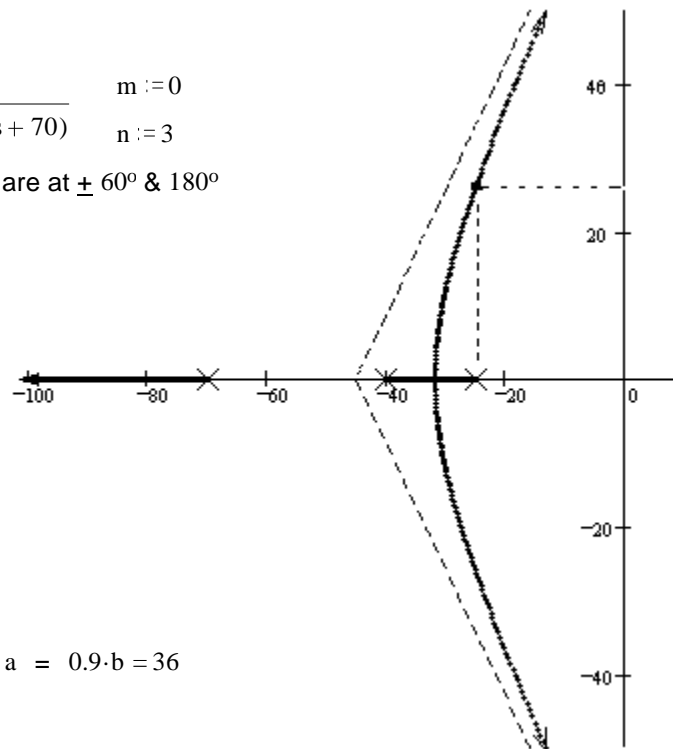

b) You wish to increase the frequency of ringing to 40 rad/sec without changing the % overshoot at all. Where should the closed-loop pole be located?

$$\frac{a}{b} = \frac{24.48}{27.2} = 0.9 \quad \text{new } b := 40 \quad \text{new } a = 0.9 \cdot b = 36$$

New location:  $s := -36 + 40j$

c) Add a LEAD compensator so that you will be able to place the closed-loop pole at the location found in b). Add the new zero at -30. Find the location of the new pole.

Angles:

from pole at -25

$$\theta_{25} := 180 \cdot \text{deg} - \text{atan}\left(\frac{40}{36 - 25}\right) \quad \theta_{25} = 105.376 \cdot \text{deg}$$

from pole at -40

$$\theta_{40} := \text{atan}\left(\frac{40}{40 - 36}\right) \quad \theta_{40} = 84.289 \cdot \text{deg}$$

from pole at -70

$$\theta_{70} := \text{atan}\left(\frac{40}{70 - 36}\right) \quad \theta_{70} = 49.635 \cdot \text{deg}$$

from new zero at -30

$$\theta_{30} := 180 \cdot \text{deg} - \text{atan}\left(\frac{40}{36 - 30}\right) \quad \theta_{30} = 98.531 \cdot \text{deg}$$

$$\theta_{25} + \theta_{40} + \theta_{70} - \theta_{30} + \theta_p = 180 \cdot \text{deg}$$

$$\theta_p := 180 \cdot \text{deg} - \theta_{25} - \theta_{40} - \theta_{70} + \theta_{30}$$

$$\theta_p = 39.23 \cdot \text{deg}$$

$$p := 36 + \frac{40}{\tan(\theta_p)} \quad p = 84.993 = 85$$

$$G_c(s) := \frac{100 \cdot (s + 30)}{(s + 25) \cdot (s + 40) \cdot (s + 70) \cdot (s + 85)}$$

$$\text{Check: } \arg \left[ \frac{100 \cdot (s + 30)}{(s + 25) \cdot (s + 40) \cdot (s + 70) \cdot (s + 85)} \right] = -179.996 \cdot \text{deg}$$

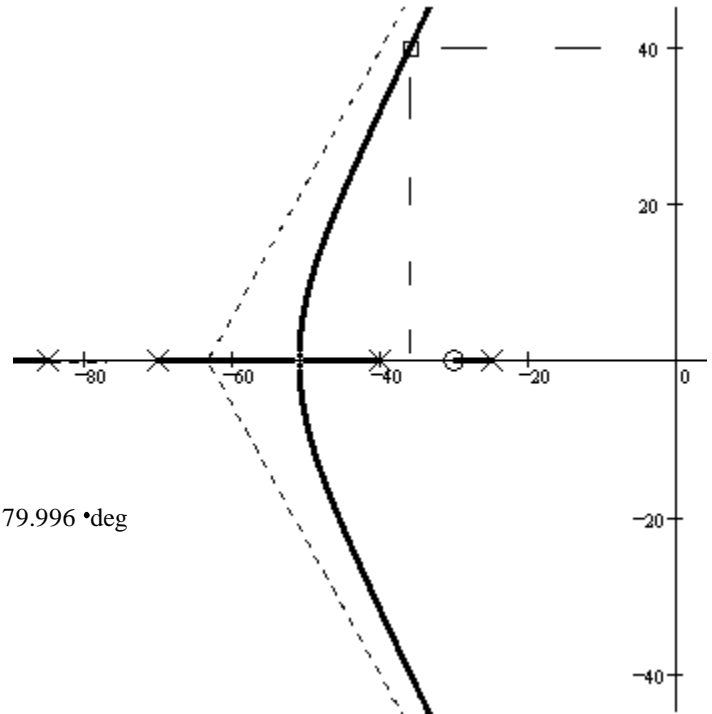

d) With the compensator in place and a closed-loop pole at the location desired in part b)

i) What is the gain?  $k := \frac{1}{|G_c(s)|} \quad k = 1369$

ii) What is the 2% settling time? Use the second-order approximation.

$$T_s = \frac{4}{36} = 0.111 \text{ sec}$$

iii) What is the steady-state error to a unit-step input?

$$G_c(0) = \frac{100 \cdot (0 + 30)}{(0 + 25) \cdot (0 + 40) \cdot (0 + 70) \cdot (0 + 85)} = 5.042 \cdot 10^{-4} \quad e_{\text{step}} = \frac{1}{1 + k \cdot G_c(0)} = 59.161 \cdot \%$$

e) Add another compensator:  $C_2(s) := \frac{s+2}{s}$  and maintain the gain of part d)

i) What is this type of compensator called and what is its purpose?

PI, used to eliminate steady-state error

ii) Calculate what you need to show that this compensator achieved its purpose.

$$G_c(s) := \frac{100 \cdot (s + 30)}{(s + 25) \cdot (s + 40) \cdot (s + 70) \cdot (s + 85)} \cdot \frac{(s + 2)}{s}$$

$$G_c(0) = \infty \quad e_{\text{step}} = \frac{1}{1 + k \cdot \infty} = 0 \cdot \%$$

f) With both compensators in place, is there possibility for improvement (quicker settling time speed and/or lower ringing)? If yes, what would be the simplest thing to do? Justify your answer.

A quick sketch of the new root-locus shows that simply decreasing the gain would improve the system

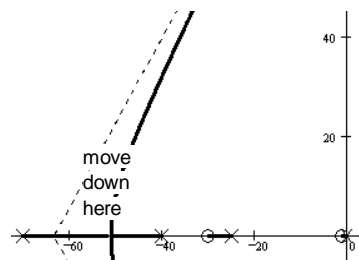

Using 2nd-order approximation:  $\frac{N(s)}{(s+a)^2 + b^2} = \frac{N(s)}{s^2 + 2 \cdot a \cdot s + a^2 + b^2} = \frac{N(s)}{s^2 + 2 \cdot \zeta \cdot \omega_n \cdot s + \omega_n^2}$

$\omega_n^2 = a^2 + b^2$        $\omega_n = \text{natural frequency}$

$\zeta \cdot \omega_n = a$

$\zeta = \frac{a}{\omega_n} = \frac{a}{\sqrt{a^2 + b^2}} = \text{damping factor}$        $\zeta = \sin\left(\text{atan}\left(\frac{a}{b}\right)\right)$

Overshoot:       $OS = e^{-\frac{\pi \cdot a}{b}}$        $\%OS = 100\% \cdot e^{-\frac{\pi \cdot a}{b}}$        $\frac{a}{b} = \frac{\ln(OS)}{-\pi}$

angle of constant damping line:  $90 \cdot \text{deg} + \text{atan}\left(\frac{a}{b}\right)$

2% settling time:  $T_s = \frac{4}{a} = \frac{4}{\zeta \cdot \omega_n}$

Time of first peak:  $T_p = \frac{\pi}{b}$

Static error constant (position):  $K_p = \lim_{s \rightarrow 0} K \cdot C(s) \cdot G(s)$        $e_{\text{step}}(\infty) = e_{\text{step}} = \frac{1}{1 + K_p}$       Nise p378

Lag compensation improves  $K_p, K_v$  and  $K_a$  by  $\frac{z_c}{p_c}$       IE:  $K_{pc} \approx K_{puc} \cdot \frac{z_c}{p_c}$

Searching along a line of constant damping:

Try s values, choosing b:  $s = -\left(\frac{a}{b} \cdot b\right) + b \cdot j$       Test:  $\arg(G(s)) \pm 180^\circ$       or  $-\text{Re}(G(s)) \gg \text{Im}(G(s))$

Linear interpolation:  $\text{new } b = b_1 - \frac{b_2 - b_1}{\text{Im}(G(s_2)) - \text{Im}(G(s_1))} \cdot \text{Im}(G(s_1))$

Can also try "a" values with slight modification of the above.

Weird forms from Nise book:

$\sigma_d = a$        $\%OS = 100\% \cdot e^{\frac{-\zeta \cdot \pi}{\sqrt{1 - \zeta^2}}}$       p195

$\omega_d = b$        $\zeta = \frac{-\ln(OS)}{\sqrt{\pi^2 + (\ln(OS))^2}}$       p195       $T_p = \frac{\pi}{\omega_n \cdot \sqrt{1 - \zeta^2}}$       p194

p378      Static error constant (ramp):  $K_v = \lim_{s \rightarrow 0} s \cdot K \cdot C(s) \cdot G(s)$        $e_{\text{ramp}} = \frac{1}{K_v}$   
(velocity)

Static error constant (parabola):  $K_a = \lim_{s \rightarrow 0} s^2 \cdot K \cdot C(s) \cdot G(s)$        $e_{\text{parabola}} = \frac{1}{K_a}$   
(acceleration)