

This method is based on the method of Linear Graphs. In Linear Graphs, all systems are reduced to a universal symbology peculiar to Linear Graphs (system graph) and then analyzed by methods very similar to those used with electric circuits. Since we, as electrical engineers, are already well versed in the symbology of electric circuits, my variation of linear graphs reduces mechanical systems to electric circuits and leaves them in that symbology for ready analysis by methods, tools and computer programs that we are already familiar with.

The objective is to be able to take a mechanical system like this:

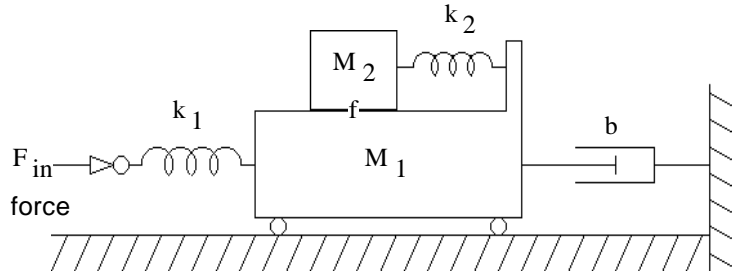

And be able to draw an equivalent electrical circuit like this:

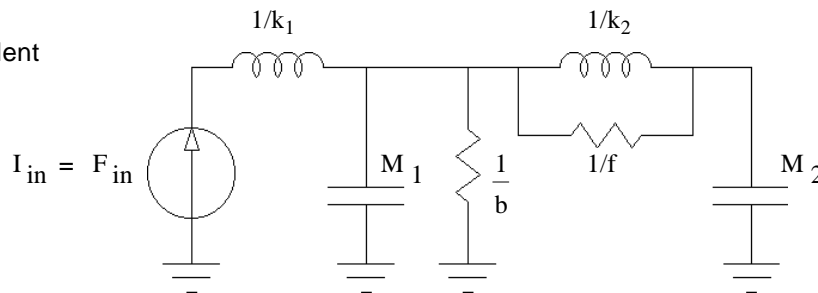

Because we know how to analyze the circuit:

Lecture: Skip forward to "Mechanical system with linear motion (translational)" Material below is for later reference.



Across and Through Variables

	<u>Across Variable</u>	<u>Through Variable</u>
Electrical	V = voltage (volts) or (V)	I = current (Amps) or (A)
Mechanical translational	v = velocity $\left(\frac{m}{sec}\right)$	F = force (newtons) or (N) or $\left(Kg \cdot \frac{m}{sec^2}\right)$
Mechanical rotational	ω = angular velocity $\left(\frac{rad}{sec}\right)$	T = torque (N·m)
Fluid	P = pressure $\left(\frac{N}{m^2}\right)$ or (Pa)	Q = flow $\left(\frac{m^3}{sec}\right)$

Elements	<u>Dissipation</u>	<u>Across Variable Energy Storage</u>	<u>Through Variable Energy Storage</u>
Electrical	R = resistance $\left(\frac{V}{A}\right)$ or (Ω)	C = capacitance $\left(\frac{A \cdot sec}{V}\right)$ or (F)	L = inductor $\left(\frac{V \cdot sec}{A}\right)$ or (H)
Mechanical translational	B = damping $\left(\frac{N \cdot sec}{m}\right)$	M = mass (Kg) or $\left(\frac{N \cdot sec^2}{m}\right)$	k = Spring constant $\left(\frac{N}{m}\right)$
Mechanical rotational	B = damping $\left[\frac{N \cdot m}{(N \cdot m \cdot sec) \text{ or } \left(\frac{rad}{sec}\right)}\right]$	J = moment of inertia $\left(\frac{N \cdot m^3}{(Kg \cdot m^2) \text{ or } \left(\frac{sec^2}{m}\right)}\right)$	k = Spring constant $\left(\frac{N \cdot m}{rad}\right)$
Fluid	R _f = fluid resistance $\left(\frac{N \cdot sec}{m^5}\right)$	C _f = fluid capacitance $\left(\frac{m^5}{N}\right)$	I = fluid inertia $\left(\frac{Kg}{m^4}\right)$

Basic Electric Circuit Analysis

Element	Parts like resistors, capacitors, inductors & transformers
Wires and connections	Direct the current, but do not affect voltage
Circuit	Wires and elements connected to form loops
Voltage	Measured as a difference across an element
Current	Flows through a wire or element
Kirchhoff's Current Law (KCL)	Current in = current out of all elements, wires & connections
Kirchhoff's Voltage Law (KVL)	Voltage gains = voltage "losses" around any circuit loop
Node	Connected wires and connections which all have the same voltage
Ground	Zero-reference node for all other nodal voltages
Branch	Connected wires and elements which all have the same current
Power $P = V \cdot I$	Power = Across variable x Through variable

Voltage Source		Constant voltage regardless of current in or out
Current Source		Constant current regardless of voltage + or -

Passive Electrical Elements

Resistors $V = I \cdot R$ Resistors dissipate power $P = V \cdot I = I^2 \cdot R = \frac{V^2}{R}$

Capacitors

$$C = \frac{Q}{V} \quad \text{farad} = \frac{\text{coul}}{\text{volt}} = \frac{\text{amp} \cdot \text{sec}}{\text{volt}} \quad v_C = \frac{1}{C} \int_{-\infty}^t i_C dt = \frac{1}{C} \int_0^t i_C dt + v_C(0) \quad i_C = C \cdot \frac{d}{dt} v_C$$

Energy stored in electric field: $E_C = \frac{1}{2} \cdot C \cdot V^2$

Capacitor voltage **cannot** change instantaneously

Laplace: Impedance: $Z_C = \frac{1}{C \cdot s}$

Inductors

$$\text{henry} = \frac{\text{volt} \cdot \text{sec}}{\text{amp}} \quad i_L = \frac{1}{L} \int_{-\infty}^t v_L dt = \frac{1}{L} \int_0^t v_L dt + i_L(0) \quad v_L = L \cdot \frac{d}{dt} i_L$$

Energy stored in magnetic field: $E_L = \frac{1}{2} \cdot L \cdot I_L^2$

Inductor current **cannot** change instantaneously

Laplace: Impedance: $Z_L = L \cdot s$

Transformers (ideal)

Ideal: $P_1 = P_2$ power in = power out

Turns ratio = $N = \frac{N_1}{N_2} = \frac{V_1}{V_2} = \frac{I_2}{I_1}$ Note: some books define the turns ratio as N_2/N_1

Equivalent impedance in primary: $Z_{eq} = N^2 \cdot Z_2 = \left(\frac{N_1}{N_2}\right)^2 \cdot Z_2$

You can replace the entire transformer and load with (Z_{eq}) .
This "impedance transformation" can work across systems.

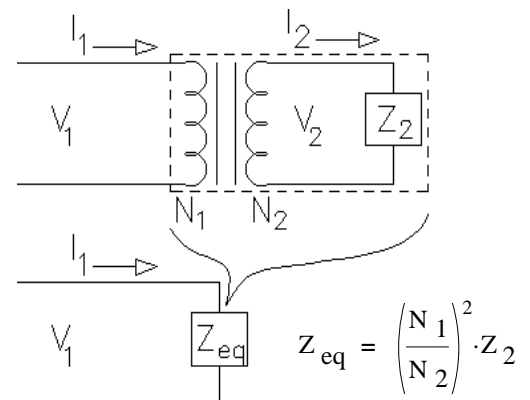

Mechanical system with linear motion (translational)

Mechanical translational

Through Variable:

F = Force (N)

Across Variable:

v = velocity $\left(\frac{m}{sec}\right)$

$$\int v dt = \frac{V(s)}{s}$$

x = displacement (m)

X(s) = displacement (m·sec) (in freq domain)

Electrical

I = current (A)

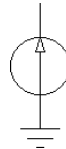
Source: 

V = voltage (V)

Source: 

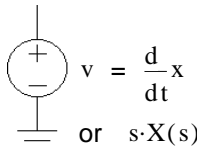
Source:  $v = \frac{d}{dt}x$ or $s \cdot X(s)$

Dissipation element:

power

$$P = v \cdot F = \frac{F^2}{B}$$

$$= v^2 \cdot B$$

Damper or friction

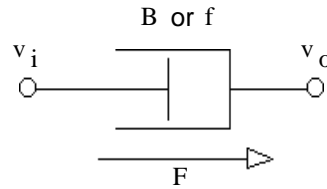

Resistor

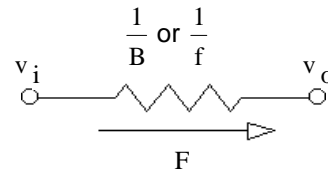

Impedance

$$\frac{1}{B} \text{ or } \frac{1}{f}$$

Through variable energy storage:

$$E = \frac{1}{2} \cdot \frac{1}{k} \cdot F^2 = \frac{1}{2} \cdot k \cdot x^2$$

(F=kx)

Spring

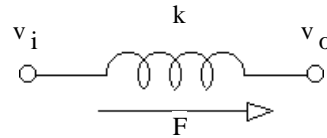

Inductor

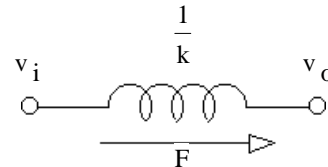

$$\frac{s}{k}$$

Springs are sometimes shown like this:

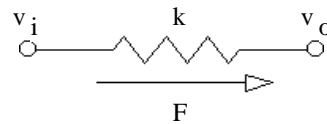

Across variable energy storage:

$$E = \frac{1}{2} \cdot M \cdot v^2$$

Mass

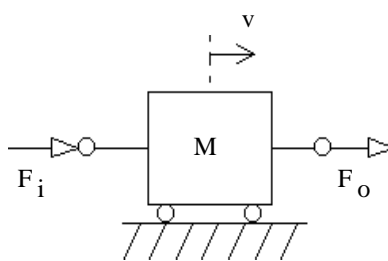

Capacitor hooked to ground

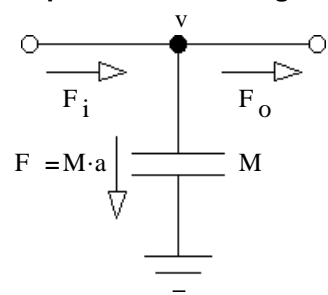

$$\frac{1}{M \cdot s}$$

Mass with friction

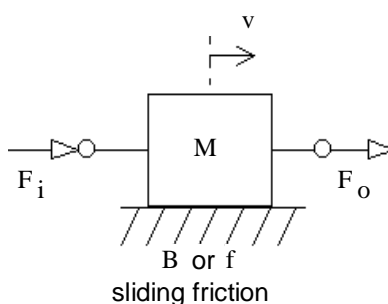

Capacitor and resistor

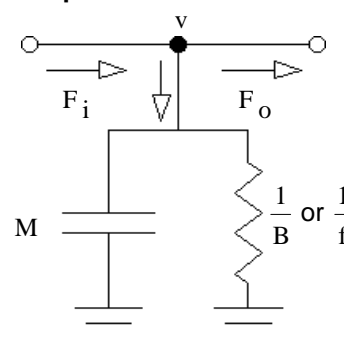

$$\frac{1}{\left(\frac{1}{M \cdot s}\right) + \left(\frac{1}{B}\right)}$$

$$\frac{1}{M \cdot s + B}$$

Do Examples 1 and 2

Transformers (ideal)

Two coils of wire that are magnetically coupled.

Electrical transformers are only useful for AC, which is not true of mechanical transformers

Transformers are used to increase/decrease voltages/currents.

Ideal: $P_1 = P_2$

power in = power out

$$\text{Turns ratio} = N = \frac{N_1}{N_2} = \frac{V_1}{V_2} = \frac{I_2}{I_1}$$

Note: some books define the turns ratio as N_2/N_1

Equivalent impedance in primary: $Z_{eq} = N^2 \cdot Z_2 = \left(\frac{N_1}{N_2}\right)^2 \cdot Z_2$

You can replace the entire transformer and load with (Z_{eq}).
This "impedance transformation" can be very handy.

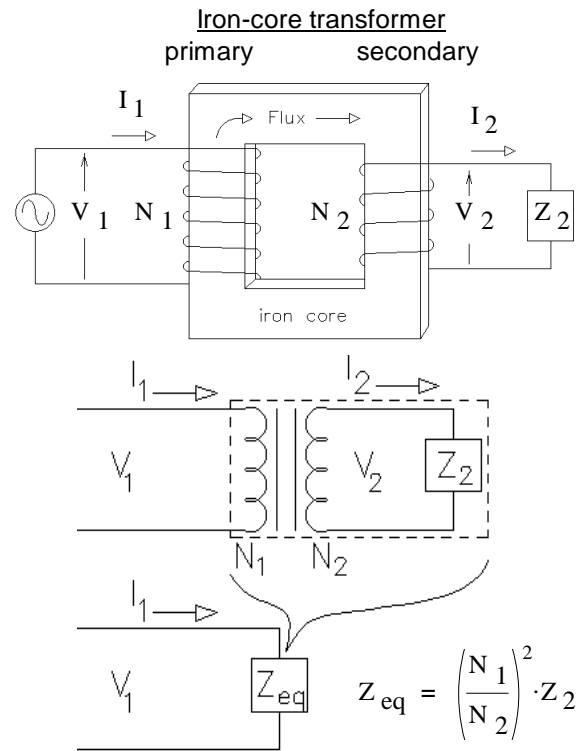

Transducers and Transformers

A transducer converts power from one type to another. We can model many of them with transformers.

Transformers increase the through variable and correspondingly decrease the across variable or vice-versa.

Mechanical "Transformers" (Translational motion)

Levers

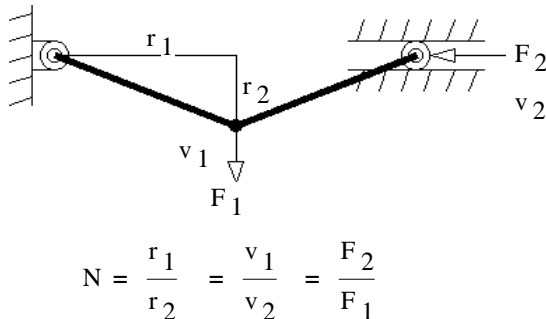
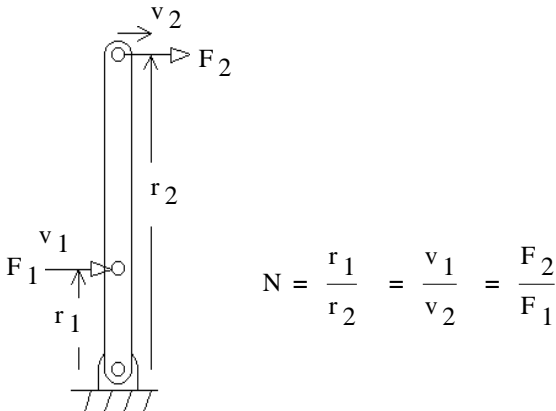

(not really this simple)

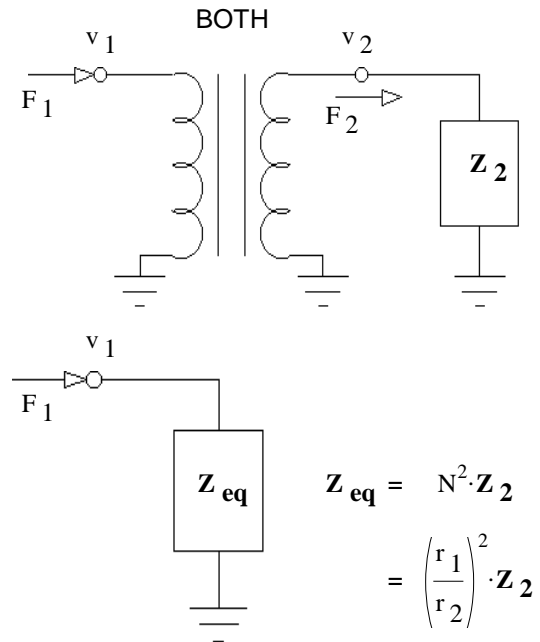

Mechanical system with circular motion (rotational)

Through Variable:

Across Variable:

$$\int \omega dt$$

$$\frac{\omega(s)}{s}$$

Mechanical rotational

T = Torque (N·m)

ω = angular velocity $\left(\frac{\text{rad}}{\text{sec}}\right)$

θ = angular displacement (rad)

$\theta(s)$ = angular displacement (rad·sec)
(in freq domain)

Electrical

I = current (A)

V = voltage (V)

Source: $\omega = \frac{d\theta}{dt}$
or $s \cdot \theta(s)$

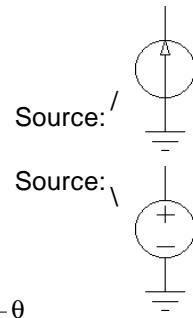

Dissipation element:

power

$$P = v \cdot T = \frac{T^2}{B}$$

$$= \omega^2 \cdot B$$

Damper or friction

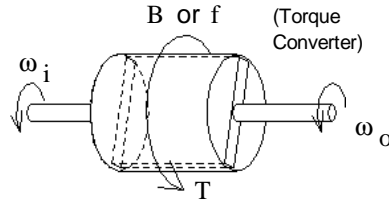

Resistor

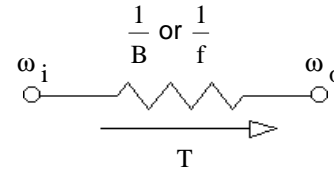

Impedance

$$\frac{1}{B} \text{ or } \frac{1}{f}$$

Through variable energy storage:

$$E = \frac{1}{2} \cdot \frac{1}{k} \cdot T^2$$

Springs

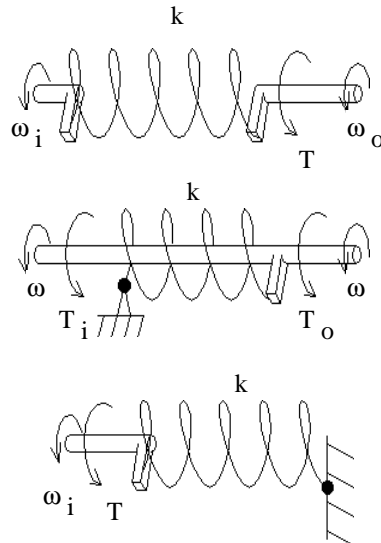

Inductor

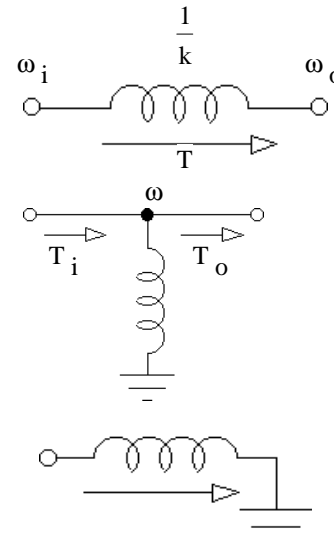

$$\frac{s}{k}$$

Across variable energy storage:

$$E = \frac{1}{2} \cdot J \cdot \omega^2$$

Moment of Inertia, J

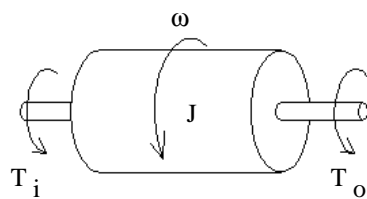

Capacitor hooked to ground

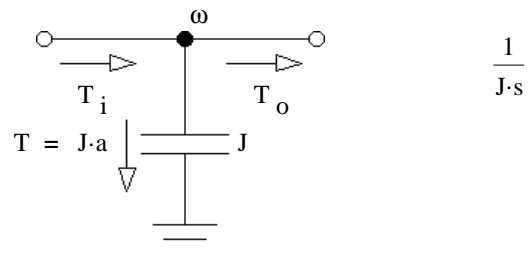

$$\frac{1}{J \cdot s}$$

J with friction

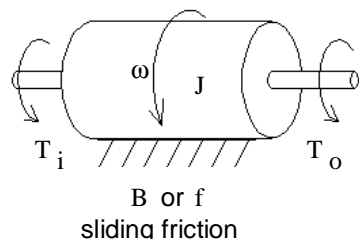

Capacitor and resistor

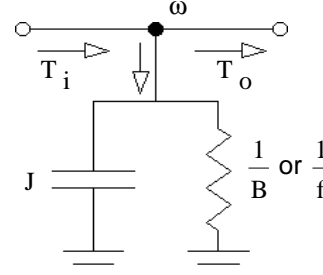

$$\frac{1}{\left(\frac{1}{J \cdot s}\right) + \left(\frac{1}{B}\right)}$$

$$\frac{1}{J \cdot s + B}$$

More Transducers and Transformers

Belts, chains, & gears

r = pitch radius of pulley or of gears

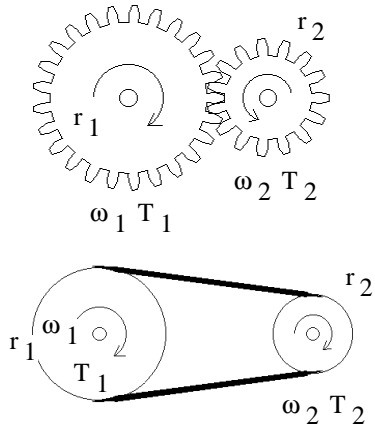

$$N = \frac{r_2}{r_1} = \frac{\omega_1}{\omega_2} = \frac{T_2}{T_1} = \text{gear tooth ratio} \left(\frac{N_2}{N_1} \right)$$

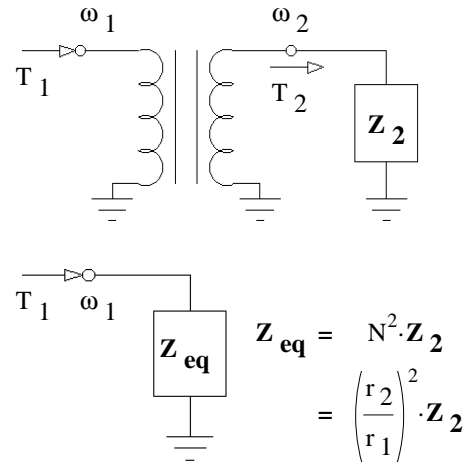

Transformation one type of motion or power to another requires a Transformer

Tires, racks, & conveyors

r = radius of wheel or pitch radius of belt pulley

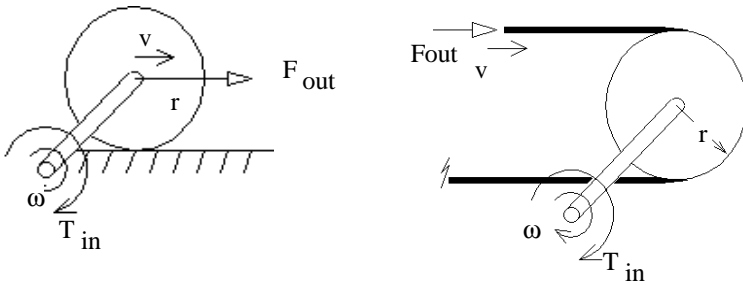

$$N = \frac{1}{r} = \frac{\omega}{v} = \frac{F}{T}$$

Note: $N = r$ if the input is linear motion and output is rotational.

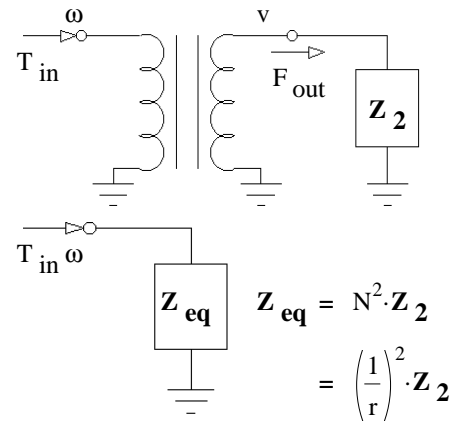

Do Example 6

DC Motors

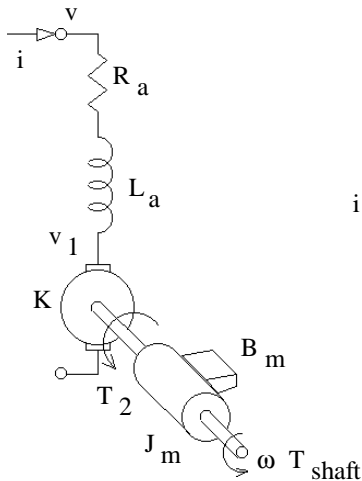

$$N = K = \frac{v_1}{\omega} = \frac{T_2}{i}$$

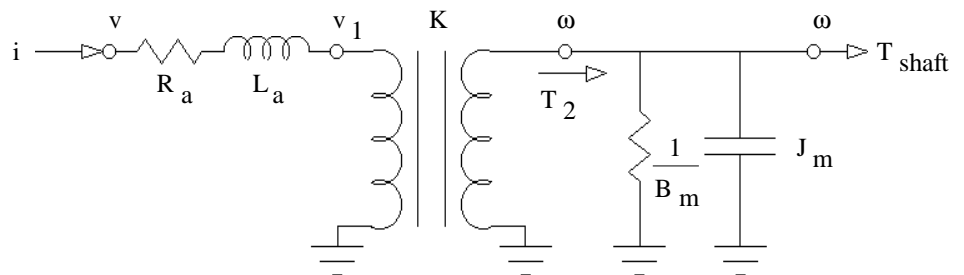

Fluid (hydraulic) system

Through Variable: **Fluid**
 $Q = \text{volumetric flow rate} \left(\frac{\text{m}^3}{\text{sec}} \right)$

Across Variable: $P = \text{Pressure} \left(\frac{\text{N}}{\text{m}^2} \right)$ or (Pa)

Dissipation element:

power
 $P = P \cdot Q$
 $= \frac{Q^2}{R_f}$
 $= P^2 \cdot R_f$

Fluid resistance

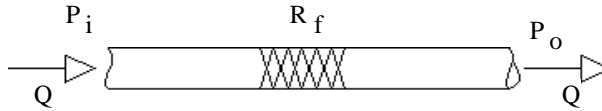

Through variable energy storage:

$$E = \frac{1}{2} \cdot I \cdot Q^2$$

Fluid Inertia

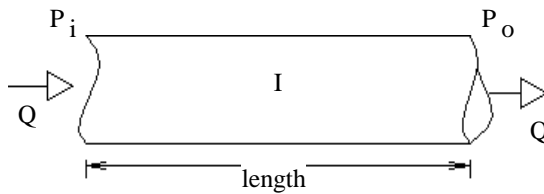

$$I = \frac{M}{A^2} = \frac{\rho \cdot \text{length}}{A}$$

Across variable energy storage:

$$E = \frac{1}{2} \cdot C_f \cdot P^2$$

Fluid Capacitors

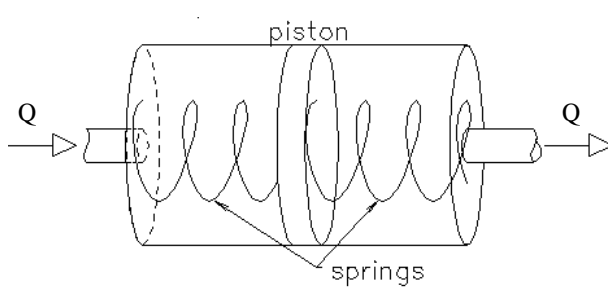

open top tank

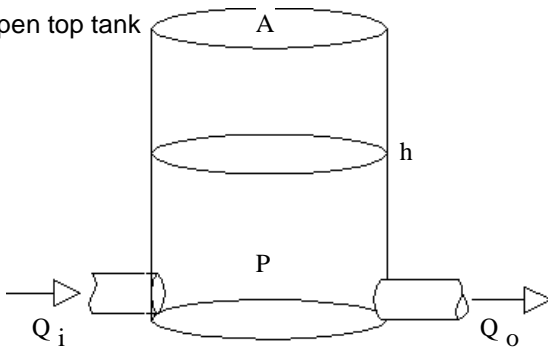

OR

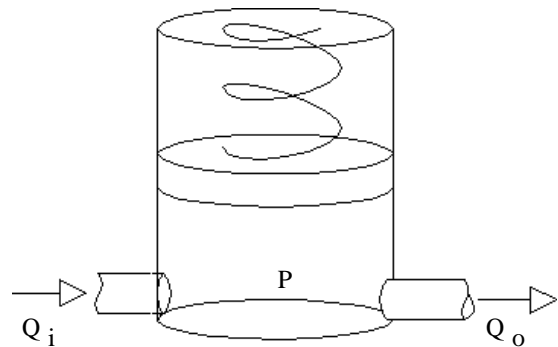

for all capacitors

$$C_f = \frac{\Delta \text{volume}}{\Delta \text{pressure}} = \frac{\Delta h \cdot A}{\Delta h \cdot \rho \cdot g} = \frac{A}{\rho \cdot g}$$

For open top tank

Capacitor hooked to ground

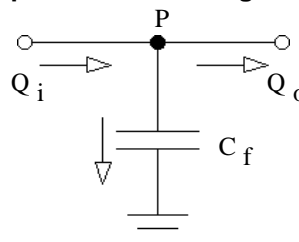

Electrical

$I = \text{current (A)}$

$V = \text{voltage (V)}$

Sources

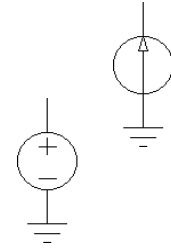

Resistor

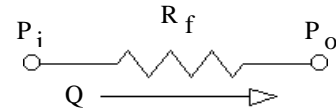

R_f

Inductor

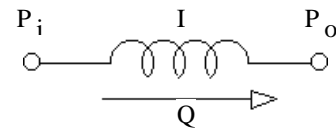

$I \cdot s$

Capacitor

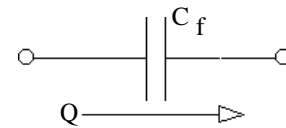

$\frac{1}{C_f s}$

Gyrators

Pistons and Turbines convert through variables to across variables & vice versa, so there are no good electrical analogies.

Yet you can still transform an impedance from a mechanical system into the fluid system. You'll find that capacitors become inductors, inductors become capacitors and parallel swaps with series.

Piston & Cylinder

Fluid
power
input

$$P = \frac{F}{A}$$

$$Q = A \cdot v$$

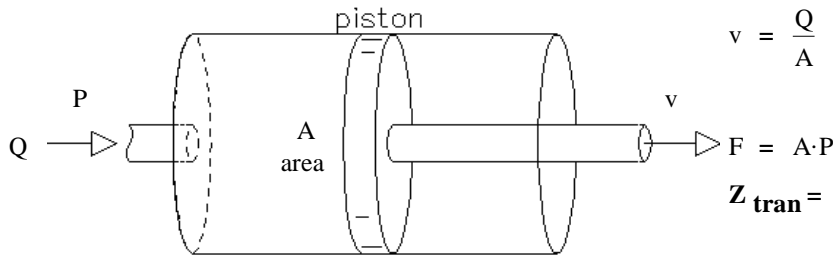

$$v = \frac{Q}{A}$$

$$F = A \cdot P$$

$Z_{\text{tran}} = \frac{v}{F} =$ an impedance representing the mechanical system connected here.

$$\text{fluid } Z_{\text{eq}} = \frac{P}{Q} = \frac{\left(\frac{F}{A}\right)}{A \cdot v} = \frac{1}{A^2} \cdot \frac{F}{v} = \frac{1}{A^2} \cdot \frac{1}{Z_{\text{tran}}} = \frac{1}{A^2 \cdot Z_{\text{tran}}}$$

If the input is mechanical linear motion power and the output is fluid power:

$$\text{translational mechanical } Z_{\text{eq}} = \frac{v}{F} = \frac{\left(\frac{Q}{A}\right)}{A \cdot P} = \frac{1}{A^2} \cdot \frac{Q}{P} = \frac{1}{A^2} \cdot \frac{1}{Z_{\text{fluid}}} = \frac{1}{A^2 \cdot Z_{\text{fluid}}}$$

Do Example 5

Turbine or Pump

Fluid
power
input
(turbine)

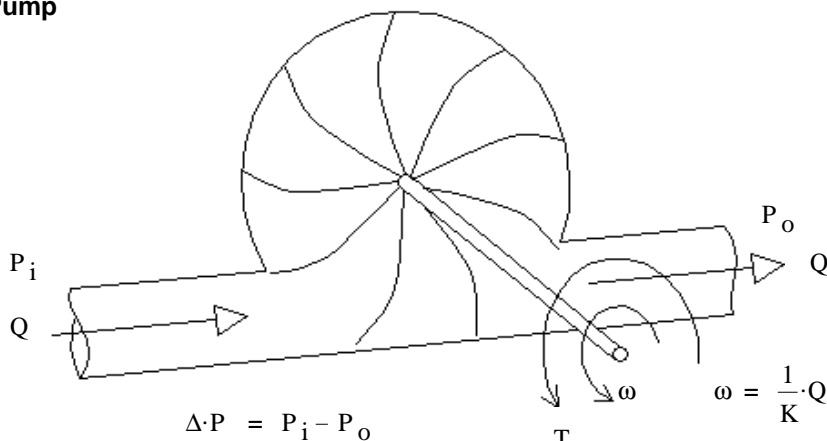

$$\Delta P = P_i - P_o$$

T

$$T = K(P_i - P_o)$$

$$= K \cdot \Delta P$$

$$\omega = \frac{1}{K} \cdot Q$$

$Z_{\text{rot}} = \frac{\omega}{T} =$ an impedance representing the mechanical system connected to the rotating shaft.

$$\text{fluid } Z_{\text{eq}} = \frac{\Delta P}{Q} = \frac{\left(\frac{T}{K}\right)}{K \cdot \omega} = \frac{1}{K^2} \cdot \frac{T}{\omega} = \frac{1}{K^2} \cdot \frac{1}{Z_{\text{rot}}} = \frac{1}{K^2 \cdot Z_{\text{rot}}} \quad (\text{turbine})$$

If the input is mechanical rotational power and the output is fluid power (pump):

$$\text{rotational mechanical } Z_{\text{eq}} = \frac{\omega}{T} = \frac{\left(\frac{Q}{K}\right)}{K \cdot \Delta P} = \frac{1}{K^2} \cdot \frac{Q}{\Delta P} = \frac{1}{K^2} \cdot \frac{1}{Z_{\text{fluid}}} = \frac{1}{K^2 \cdot Z_{\text{fluid}}} \quad (\text{pump})$$

Note: $\Delta P = P_o - P_i$ across the pump

Example 1

Mechanical system

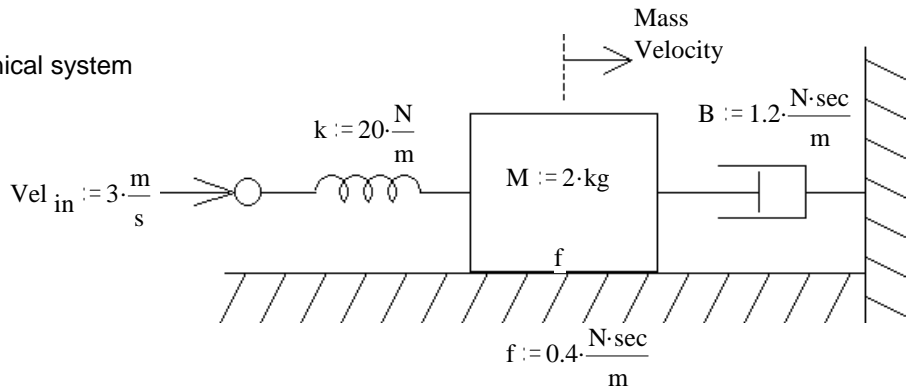

Elements

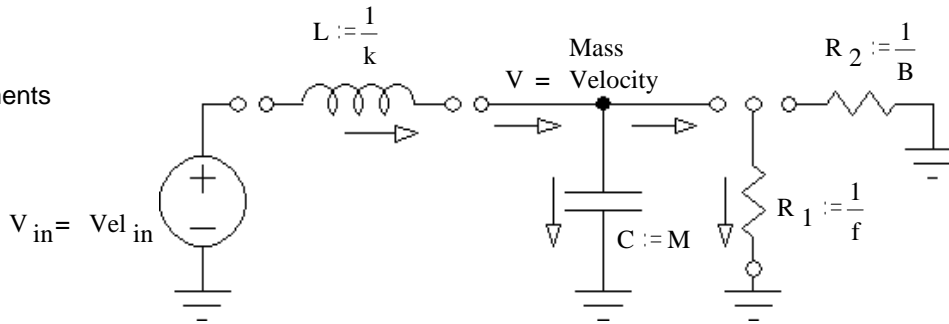

Circuit

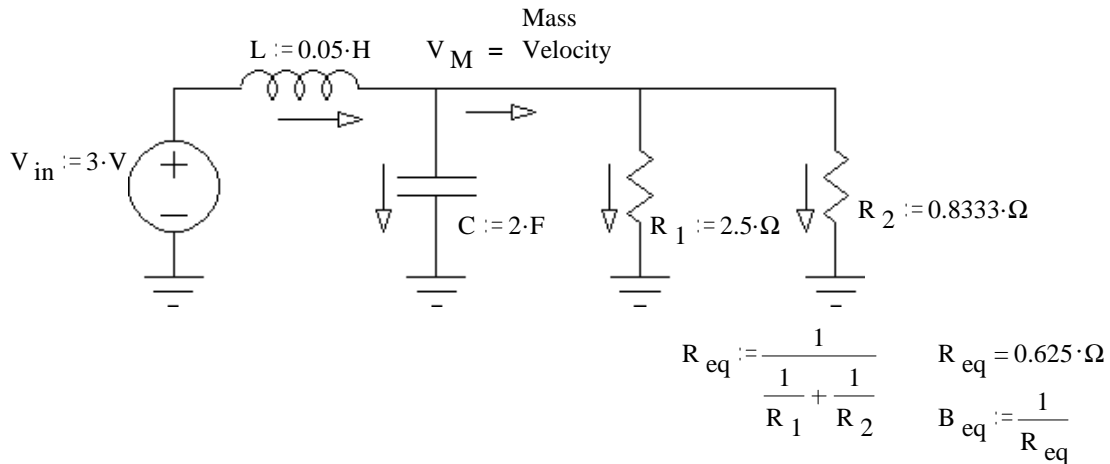

Transfer function

$$\frac{V_M(s)}{V_{in}(s)} = \frac{1}{C \cdot s + \frac{1}{R_{eq}}} \cdot \frac{\left(C \cdot s + \frac{1}{R_{eq}} \right)}{L \cdot s + \frac{1}{C \cdot s + \frac{1}{R_{eq}}}} = \frac{1}{L \cdot C \cdot s^2 + \frac{L}{R_{eq}} \cdot s + 1} \cdot \frac{\left(\frac{1}{L \cdot C} \right)}{\left(\frac{1}{L \cdot C} \right)} = \frac{1}{s^2 + \frac{1}{C \cdot R_{eq}} \cdot s + \frac{1}{L \cdot C}}$$

$$\frac{V_M(s)}{Vel_{in}(s)} = \frac{\frac{k}{M}}{s^2 + \frac{B_{eq}}{M} \cdot s + \frac{k}{M}} = \frac{\frac{20 \cdot N}{2 \cdot kg \cdot m}}{s^2 + \frac{1.6 \cdot N \cdot sec}{2 \cdot kg \cdot m} \cdot s + \left(\frac{20 \cdot N}{2 \cdot kg \cdot m} \right)} = \frac{10}{s^2 + 0.8 \cdot s + 10} \quad \text{same, either way}$$

without units

ECE 3510 Mechanical to Electrical Examples p.2

Example 2

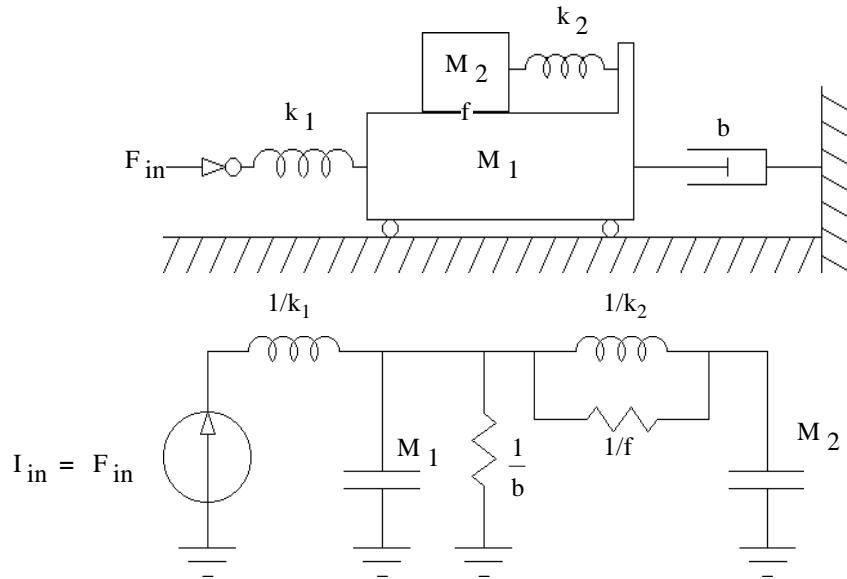

Example 3

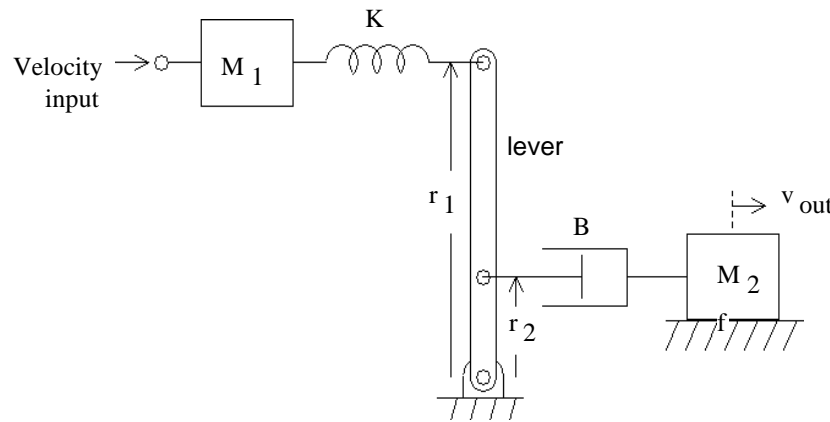

Circuit with a transformer.

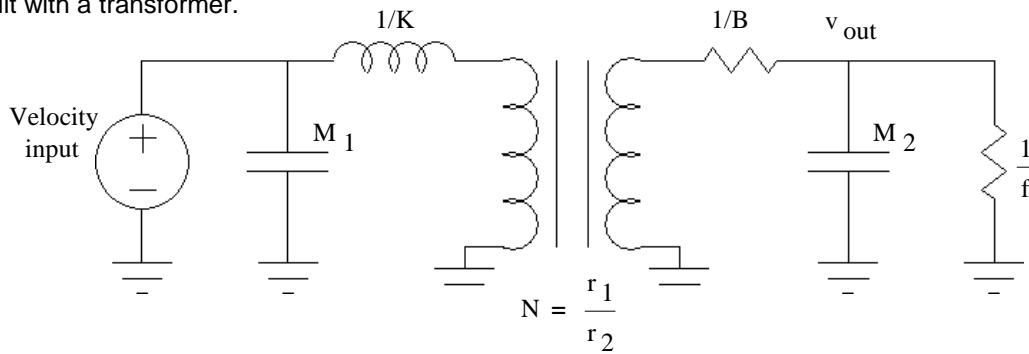

Circuit without a transformer.

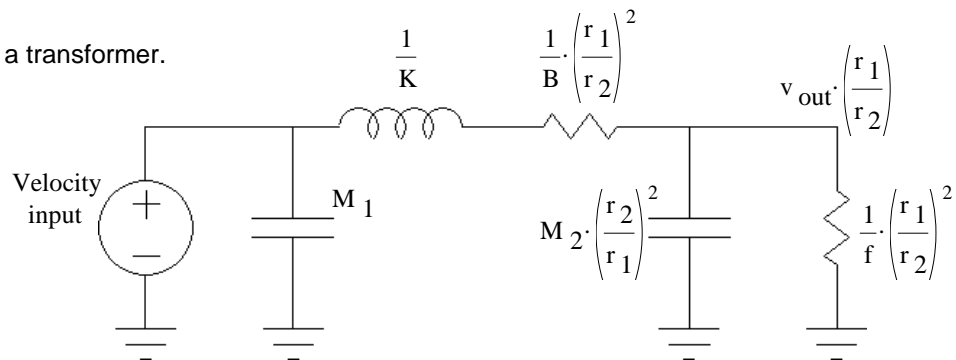

ECE 3510 Mechanical to Electrical Examples p.3

Example 4

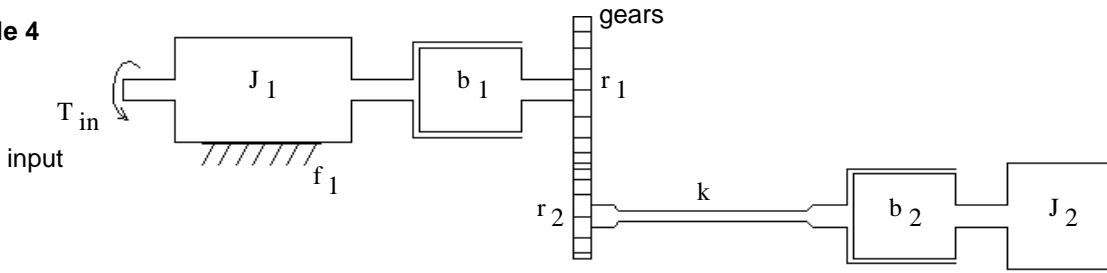

Circuit with a transformer.

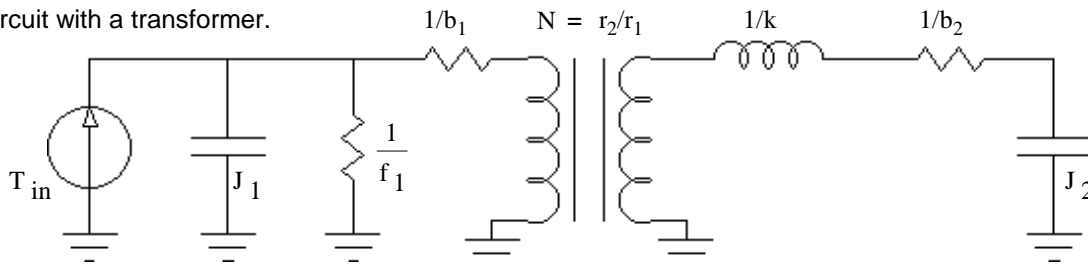

Circuit without a transformer.

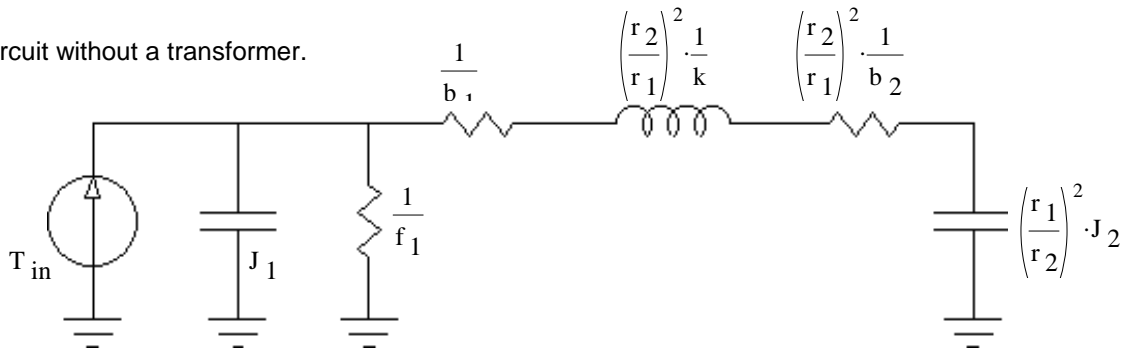

Example 5, fluids

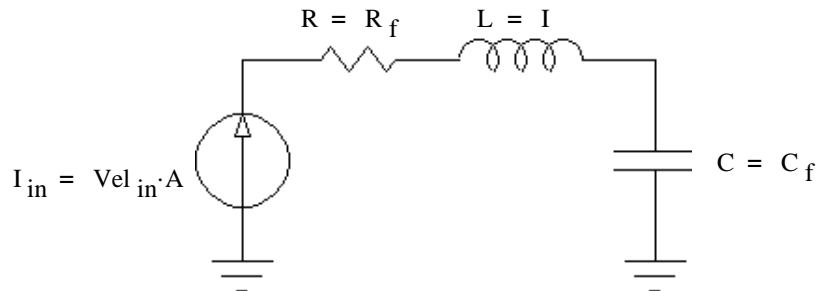
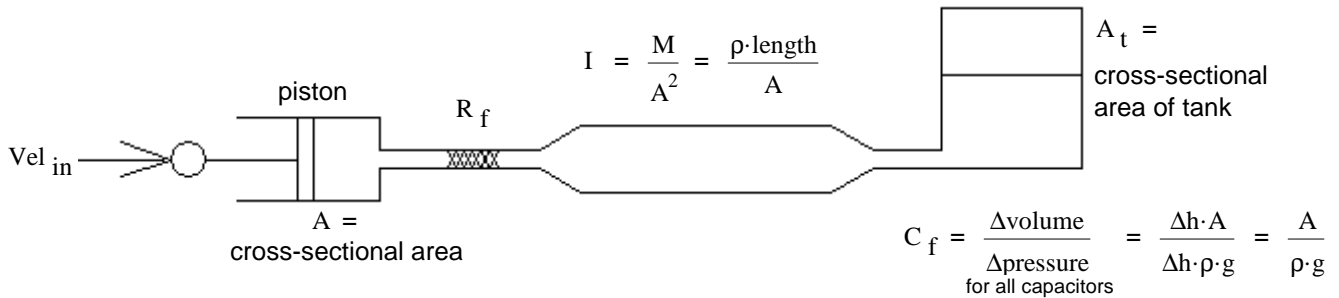

ECE 3510 Mechanical to Electrical Examples p.4

Example 6

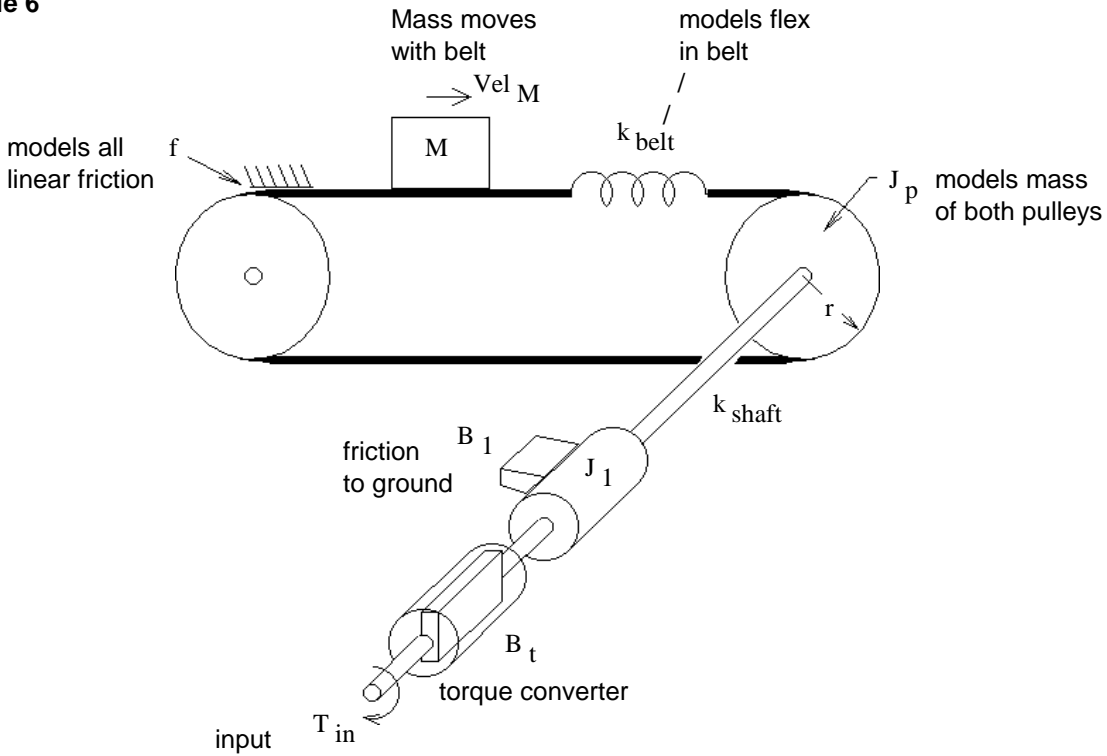

Circuit with a transformer.

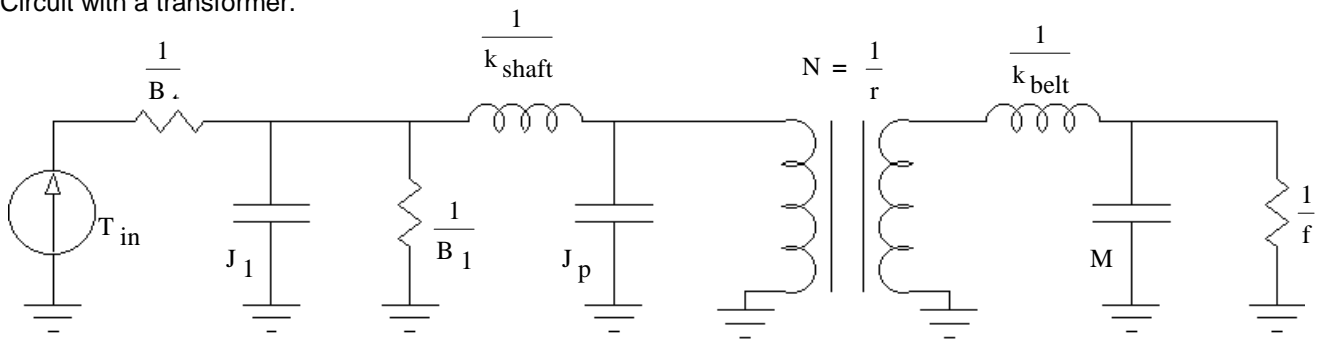

Circuit without a transformer.

