

## Non-strictly-proper transforms section 2.2.5, p.16 in Bodson text

What if the order of the numerator is equal to or even greater than the order of the denominator?  $m \geq n$  ?

Example:  $F(s) = \frac{2 \cdot s^2 + 100}{s^2 + 8 \cdot s + 41}$   $m := 2$   
 $n := 2$

First divide, before partial fraction expansion  $s^2 + 8 \cdot s + 41 \left\{ \begin{array}{l} \overline{2 \cdot s^2 + 0 \cdot s + 100} \\ \hline \end{array} \right.$

"remainder"

$$F(s) = \frac{2 \cdot s^2 + 100}{s^2 + 8 \cdot s + 41} =$$

$$f(t) =$$

Delta functions are not very common in real life.

Non-strictly-proper transforms are just as common.

## Properties of Signals

Can you tell what  $f(t)$  must be just by looking at  $F(s)$ ? YES, somewhat...

$$\frac{s+5}{s \cdot (s^2 + 4 \cdot s + 13) \cdot (s-10)}$$

$$\frac{s+5}{s \cdot (s^2 + 64) \cdot (s+10)}$$

$$\frac{s+5}{s \cdot (s^2 - 4 \cdot s + 13) \cdot (s+10)}$$

$$\frac{s+5}{s \cdot (s^2 + 4 \cdot s + 13)^2 \cdot (s+10)}$$

$$\frac{s+5}{s^3 \cdot (s^2 + 4 \cdot s + 13)^2 \cdot (s+10)^2}$$

Now that we've reviewed Laplace transforms of signals, we can move on to systems, the transfer function, and system block diagrams using blocks which contain transfer functions.

Consider a circuit:

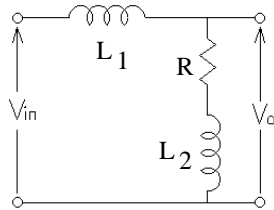

$$H(s) = \frac{V_o(s)}{V_{in}(s)} = \frac{R + L_2 \cdot s}{R + L_1 \cdot s + L_2 \cdot s} = \frac{R + L_2 \cdot s}{R + (L_1 + L_2) \cdot s}$$

$$= \frac{L_2 \cdot s + R}{(L_1 + L_2) \cdot s + R}$$

This could be represented in as a block operator:

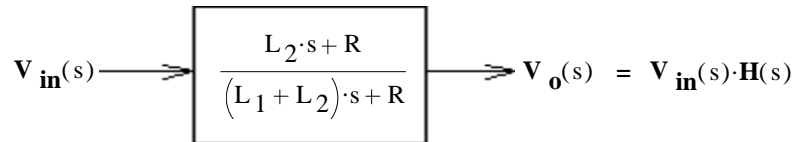

Transfer functions can be written for all kinds of devices and systems, not just electric circuits and the input and output do not have to be similar. For instance, the potentiometers used to measure angular position in the crude servo of lab 1 can be represented like this:

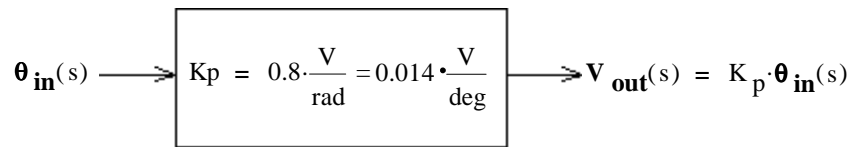

In general:

$$H(s) = \frac{\text{output}}{\text{input}} = \frac{Y(s)}{X(s)}$$

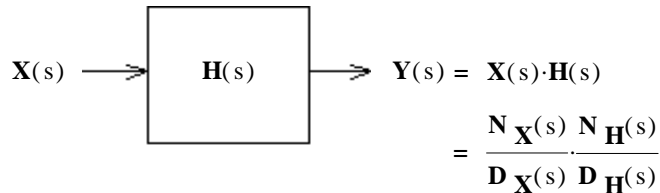

X and Y could be anything from small electrical signals to powerful mechanical motions or forces.

The output signal has the poles of both the input AND the transfer function.

**Serial - path systems** Two blocks with transfer functions A(s) and B(s) in a row would look like this:

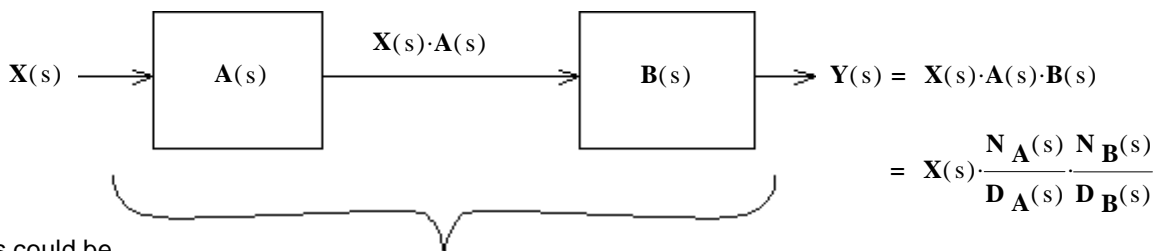

The two blocks could be replaced by a single equivalent block:

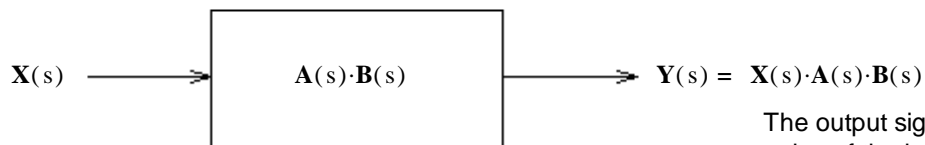

The output signal has the poles of the input AND BOTH transfer functions.

Summer blocks can be used to add signals:

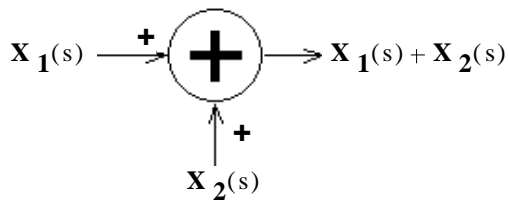

OR

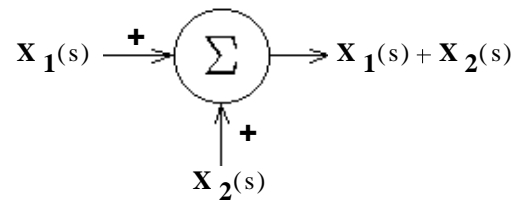

or subtract signals:

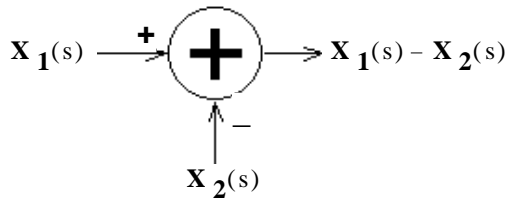

OR

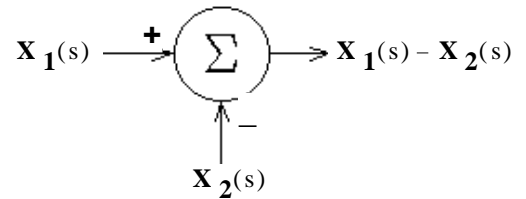

### Parallel - path systems

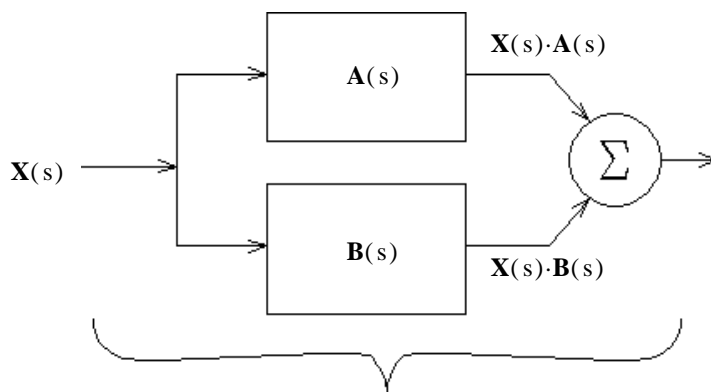

$$Y(s) = X(s) \cdot (A(s) + B(s))$$

$$= X(s) \cdot \left( \frac{N_A(s)}{D_A(s)} + \frac{N_B(s)}{D_B(s)} \right)$$

$$= X(s) \cdot \left( \frac{N_A(s) \cdot D_B(s) + D_A(s) \cdot N_B(s)}{D_A(s) \cdot D_B(s)} \right)$$

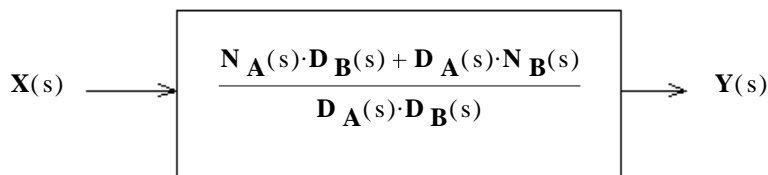

Again, the output signal has the poles of the input AND BOTH transfer functions.

The two blocks could be replaced by a single equivalent block:

**A feedback loop system** is particularly interesting and useful:

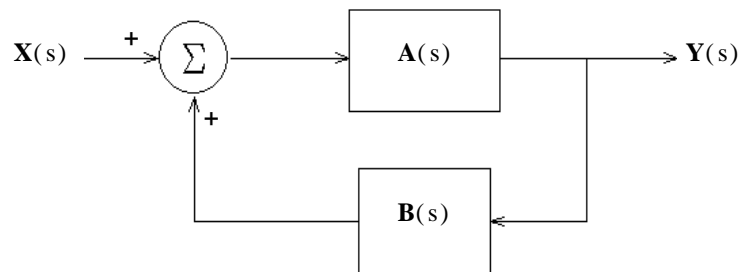

The entire loop can be replaced by a single equivalent block:

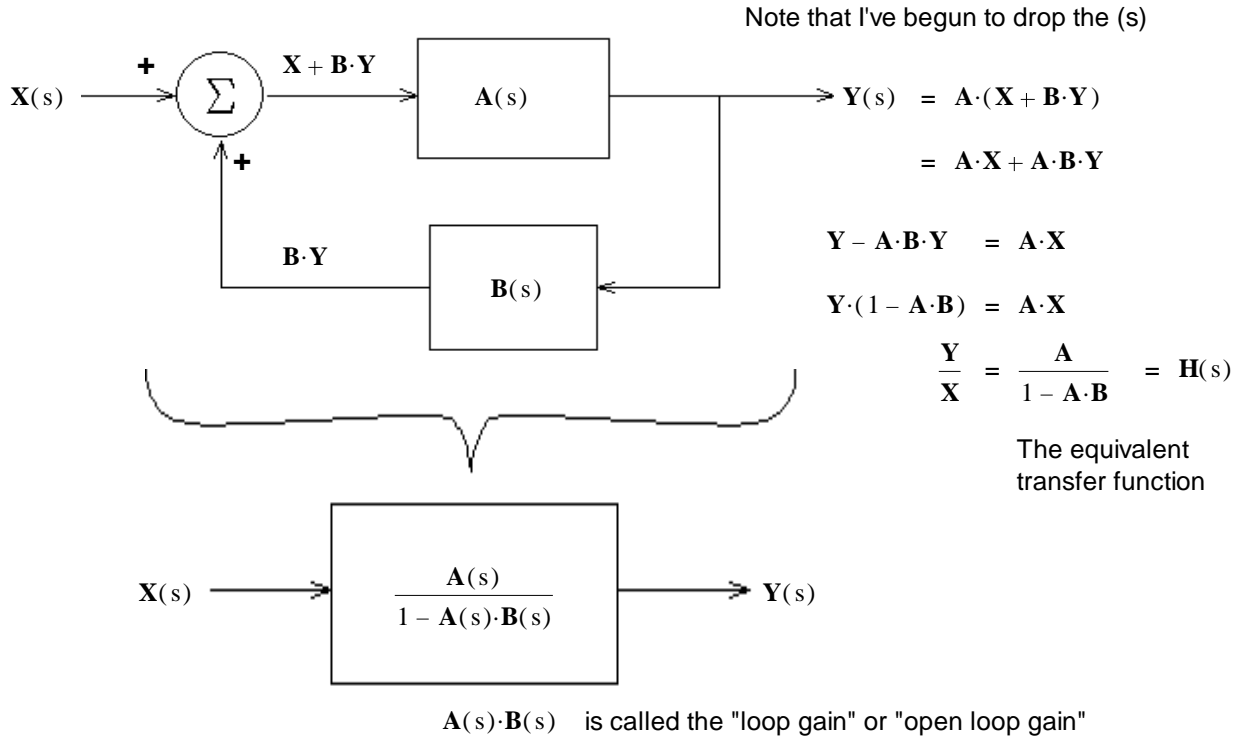

Negative feedback is more common and is used as a control system:

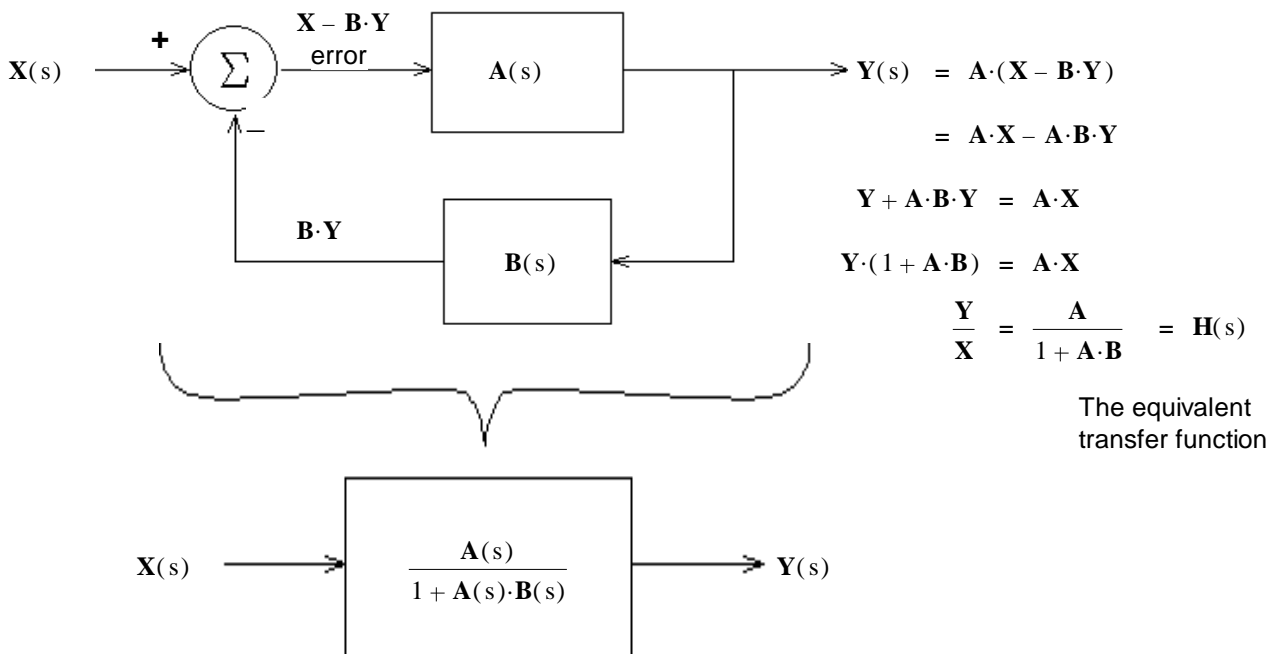

This is called a "closed loop" system, whereas a system without feedback is called "open loop". The term "open loop" is often used to describe a system that is out of control.

**The output signal poles are different than either the poles of the input or the transfer functions.**

Different poles means different characteristics! This implies that you might start with a stable system and make an unstable system or (more productively) start with an unstable system and make a stable system.

# ECE 3510 Lecture 6 & 7 notes p4

The servo used in our lab can be represented by:

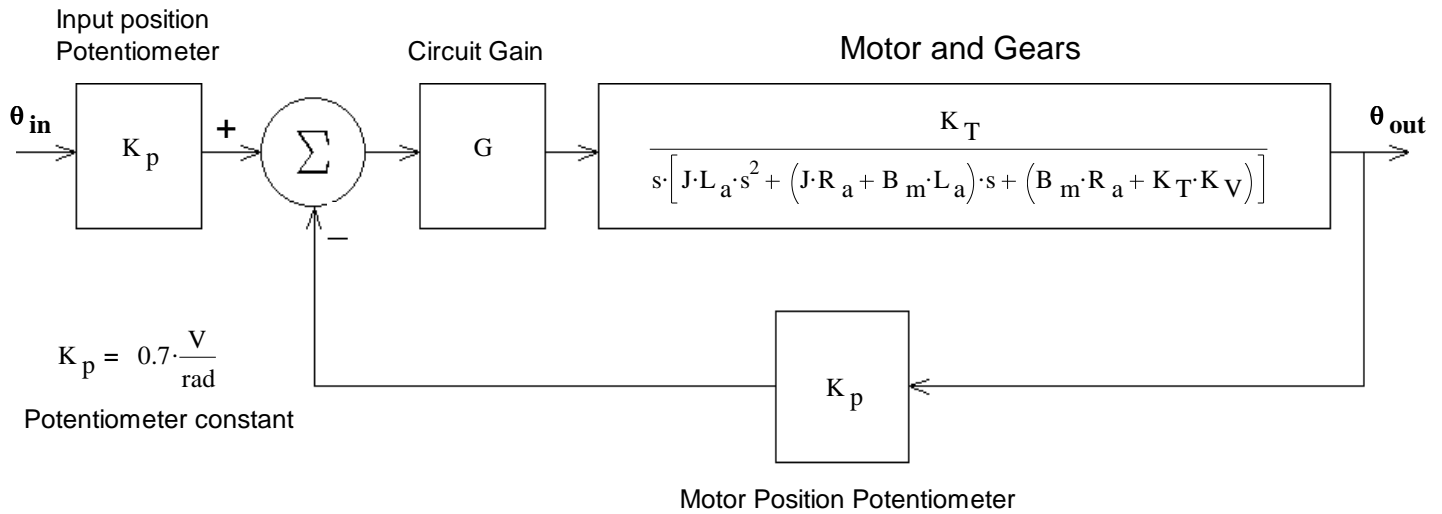

$$H(s) = \frac{\theta_{\text{out}}(s)}{\theta_{\text{in}}(s)} = \frac{G \cdot K_T \cdot K_p}{s \cdot [J \cdot L_a \cdot s^2 + (J \cdot R_a + B_m \cdot L_a) \cdot s + (B_m \cdot R_a + K_T \cdot K_V)] + K_p \cdot G \cdot K_T}$$

See the appendix to lab 1 for the complete analysis

**Ex. 1** a) A feedback system is shown in the figure. What is the transfer function of the whole system, with feedback.

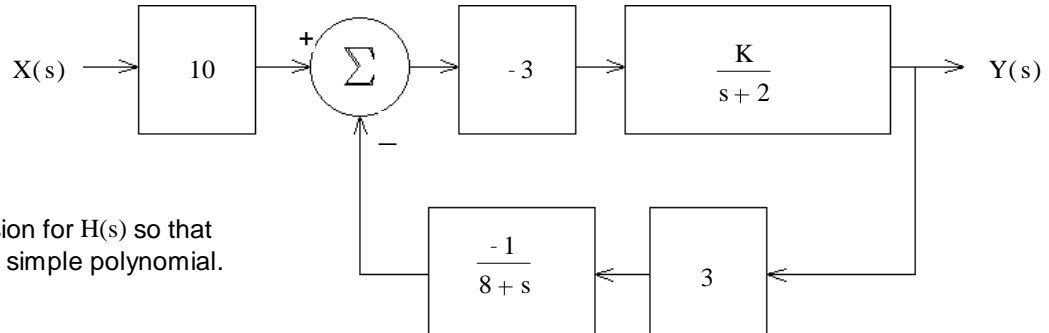

$$H(s) = \frac{Y(s)}{X(s)} = ?$$

Simplify your expression for  $H(s)$  so that the denominator is a simple polynomial.

Feedback loop:

$$\text{Loop gain: } L = \left( \frac{-3 \cdot K}{s+2} \right) \cdot \left( \frac{-1 \cdot 3}{8+s} \right)$$

Simplification:

$$A_f = \frac{\left( \frac{-3 \cdot K}{s+2} \right)}{1 + \left( \frac{-3 \cdot K}{s+2} \right) \cdot \left( \frac{-3}{8+s} \right)} = \frac{(-3 \cdot K) \cdot (s+8)}{(s+2) \cdot (8+s) + (3 \cdot K) \cdot 3} = \frac{(-3 \cdot K) \cdot s - K \cdot 24}{s^2 + 10 \cdot s + 16 + 9 \cdot K}$$

Whole system:

$$H(s) = 10 \cdot \frac{-3 \cdot K \cdot s - 24 \cdot K}{s^2 + 10 \cdot s + 16 + 9 \cdot K} = \frac{-30 \cdot K \cdot (s+8)}{s^2 + 10 \cdot s + 16 + 9 \cdot K}$$

# ECE 3510 Lecture 7 Examples p5

b) Find the value of K to make the transfer function critically damped. Answer may be left as a fraction.

characteristic eq.:  $0 = s^2 + 10 \cdot s + 16 + 9 \cdot K$

to solve for the poles:  $s = \frac{-10 + \sqrt{10^2 - 4 \cdot (16 + 9 \cdot K)}}{2}$  at critical damping, the part under the radical is zero.

thus:  $10^2 = 4 \cdot (16 + 9 \cdot K)$

$100 = 64 + 36 \cdot K$

$K = \frac{100 - 64}{36} = \frac{36}{36} = 1$  solve for K

c) If K is less than the value found in part b), will the system be under-, critical-, or overdamped?

$10^2 - 4 \cdot (16 + 9 \cdot K) > 0$  so it will be overdamped

d) If  $K := 5$ , find the pole(s) of the transfer function:

characteristic eq.:  $0 = s^2 + 10 \cdot s + 16 + 9 \cdot K = s^2 + 10 \cdot s + 61$

$\frac{-10 + \sqrt{10^2 - 4 \cdot 61}}{2} = -5 + 6j$

$\frac{-10 - \sqrt{10^2 - 4 \cdot 61}}{2} = -5 - 6j$

e) If  $K := 5$ , find the zero(s) of the transfer function:

$s + 8 = 0$

$s = -8$

**Ex.2** a) Find the transfer function of the circuit shown. Consider  $I_C$  as the "output".

Properly simplify all your expressions for  $H(s)$ . By this I mean that the numerator and denominator should both be simple polynomials or factored polynomials. There should be no  $1/s^n$  terms in either the numerator or denominator. Also, there should be no coefficient on the highest-order term in the denominator

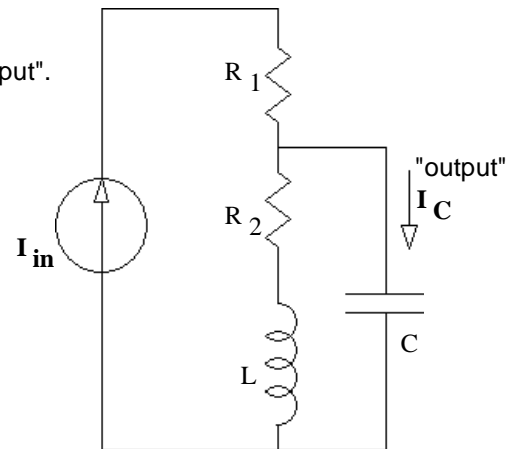

$H(s) = \frac{I_C(s)}{I_{in}(s)} = ?$

Current divider:

$$I_C(s) = I_{in}(s) \cdot \frac{\frac{1}{C \cdot s}}{\left(\frac{1}{C \cdot s}\right) + \frac{1}{R_2 + Ls}} = I_{in}(s) \cdot \frac{C \cdot s}{C \cdot s + \frac{1}{R_2 + Ls}}$$

$$H(s) = \frac{I_C(s)}{I_{in}(s)} = \frac{C \cdot s}{C \cdot s + \frac{1}{R_2 + Ls}} \cdot \frac{(R_2 + Ls)}{(R_2 + Ls)} = \frac{C \cdot R_2 + L \cdot C \cdot s^2}{C \cdot R_2 \cdot s + L \cdot C \cdot s^2 + 1} \cdot \left(\frac{1}{LC}\right) = \frac{\frac{R_2}{L} \cdot s + s^2}{\frac{R_2}{L} \cdot s + s^2 + \frac{1}{L \cdot C}}$$

$$= \frac{s \cdot \left(s + \frac{R_2}{L}\right)}{s^2 + \frac{R_2}{L} \cdot s + \frac{1}{L \cdot C}}$$

b) How many zeroes does this transfer function have? 2, 0 and  $-R_2/L$

c) How many poles does this transfer function have? 2 at:  $-\frac{R_2}{2L} \pm \frac{1}{2} \sqrt{\left(\frac{R_2}{L}\right)^2 - \frac{4}{L \cdot C}}$

## ECE 3510 Lecture 7 Examples p6

Ex.3 a) Find the transfer function of the circuit shown.  
 $V_i$  is the input and  $V_o$  is the output.

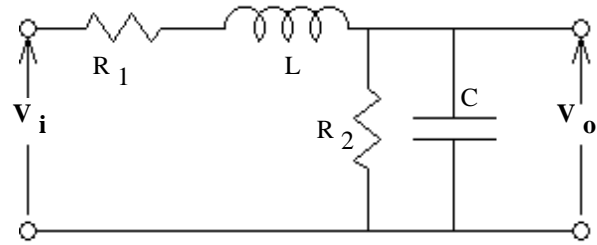

$$\begin{aligned}
 H(s) = \frac{V_o(s)}{V_i(s)} &= \frac{\frac{1}{R_2}}{R_1 + Ls + \frac{1}{R_2}} \cdot \frac{1}{R_2 + Cs} = \frac{1}{R_1 \left( \frac{1}{R_2} + Cs \right) + Ls \left( \frac{1}{R_2} + Cs \right) + 1} \\
 &= \frac{1}{\frac{R_1}{R_2} + R_1 \cdot Cs + \frac{Ls}{R_2} + Ls \cdot Cs + 1} \cdot \frac{1}{L \cdot C} = \frac{\frac{1}{L \cdot C}}{\frac{R_1}{R_2} \cdot \frac{1}{L \cdot C} + \frac{R_1 \cdot C}{L \cdot C} \cdot s + \frac{Ls}{R_2} \cdot \frac{1}{L \cdot C} + s^2 + \frac{1}{L \cdot C}} \\
 &= \frac{\frac{1}{L \cdot C}}{s^2 + \left( \frac{R_1}{L} + \frac{1}{R_2 \cdot C} \right) \cdot s + \left( 1 + \frac{R_1}{R_2} \right) \cdot \frac{1}{L \cdot C}} \\
 \text{b) Find the characteristic equation of the circuit shown.} \quad &0 = s^2 + \left( \frac{R_1}{L} + \frac{1}{R_2 \cdot C} \right) \cdot s + \left( 1 + \frac{R_1}{R_2} \right) \cdot \frac{1}{L \cdot C}
 \end{aligned}$$

c) The solutions to the characteristic equation are called the \_\_\_\_\_ of the transfer function. Poles

d) Does the transfer function have one or more zeros? If yes, express it (them) in terms of  $R_1$ ,  $R_2$ ,  $C$ , &  $L$ . NO

## General Interconnected System

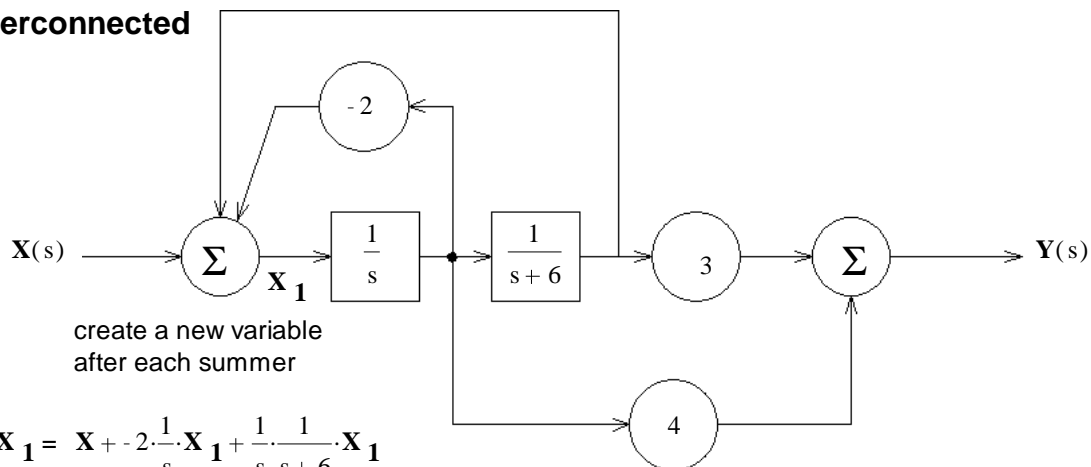

$$X_1 = X + -2 \cdot \frac{1}{s} \cdot X_1 + \frac{1}{s} \cdot \frac{1}{s+6} \cdot X_1$$

$$X_1 \left[ 1 + \frac{2}{s} - \frac{1}{s \cdot (s+6)} \right] = X = X_1 \left[ \frac{s \cdot (s+6)}{s \cdot (s+6)} + \frac{2 \cdot (s+6)}{s \cdot (s+6)} - \frac{1}{s \cdot (s+6)} \right] = X_1 \left[ \frac{s^2 + 8s + 11}{s \cdot (s+6)} \right]$$

$$X_1 = \frac{s \cdot (s+6)}{s^2 + 8s + 11} \cdot X$$

$$\begin{aligned}
 Y &= 3 \cdot \left( \frac{1}{s} \cdot \frac{1}{s+6} \right) \cdot X_1 + 4 \cdot \frac{1}{s} \cdot X_1 = 3 \cdot \left[ \frac{1}{s \cdot (s+6)} \right] \cdot \left[ \frac{s \cdot (s+6)}{s^2 + 8s + 11} \cdot X \right] + 4 \cdot \frac{1}{s} \cdot \left[ \frac{s \cdot (s+6)}{s^2 + 8s + 11} \cdot X \right] \\
 &= \frac{3 + (4 \cdot s + 24)}{s^2 + 8s + 11} \cdot X = \frac{4 \cdot s + 27}{s^2 + 8s + 11} \cdot X
 \end{aligned}$$

$$H(s) = \frac{Y}{X} = \frac{4 \cdot s + 27}{s^2 + 8s + 11}$$

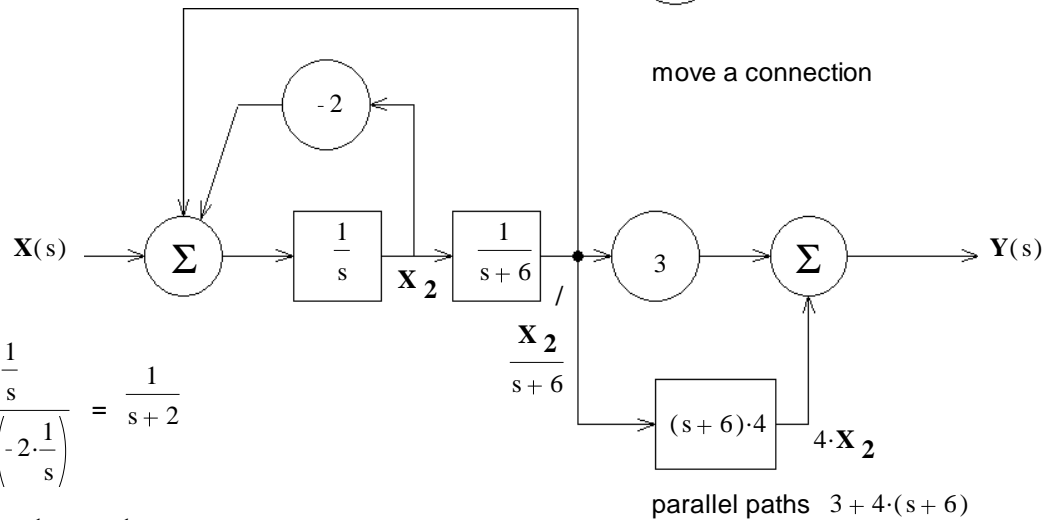
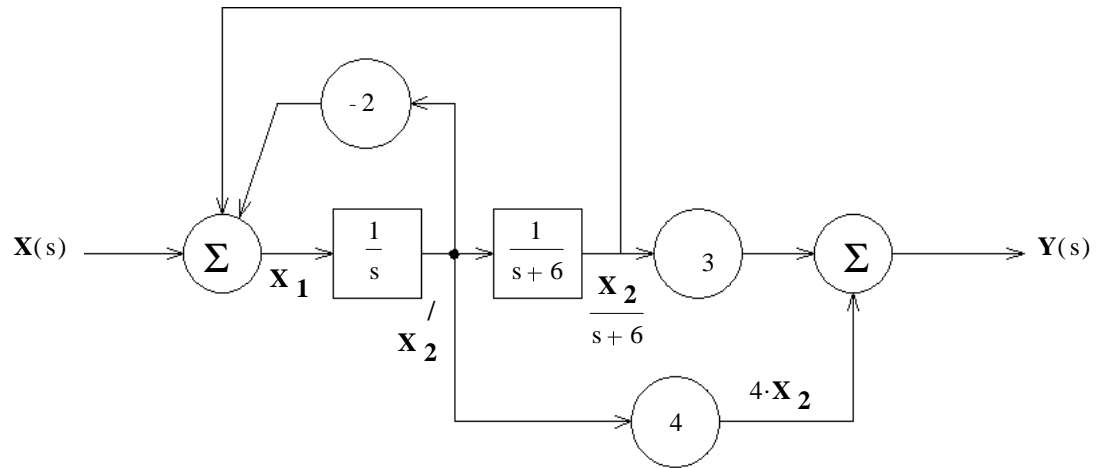

inner loop  $\frac{\frac{1}{s}}{1 - (-2 \cdot \frac{1}{s})} = \frac{1}{s + 2}$

outer loop  $\frac{\frac{1}{(s + 2)} \cdot \frac{1}{(s + 6)}}{1 - 1 \cdot \frac{1}{(s + 2)} \cdot \frac{1}{(s + 6)}} = \frac{1}{(s + 2) \cdot (s + 6) - 1} = \frac{1}{s^2 + 8 \cdot s + 12 - 1} = \frac{1}{s^2 + 8 \cdot s + 11}$

whole transfer function  $H(s) = \frac{1}{s^2 + 8 \cdot s + 11} \cdot (3 + 4 \cdot (s + 6)) = \frac{4 \cdot s + 27}{s^2 + 8 \cdot s + 11}$

**Bounded-Input Bounded-Output (BIBO) Stable**

A system is considered BIBO stable if the output is bounded for any bounded input.

A bounded input could have single poles on the imaginary axis at any location.

A bounded output may not have double poles on the imaginary axis or any poles in the RHP (Right-half-plane).

The output will have all the poles of the input plus all the poles of the system. (except in rare pole-zero cancellations.)

Therefore: A BIBO system may not have any poles on the imaginary axis or any poles in the RHP.

Examples of systems with poles on the imaginary axis: If the output of a DC motor is angular position of the shaft then it has a pole at the origin. The response to a DC input is a shaft that keeps turning and the position grows without bounds. This system is not BIBO stable. (If the output is shaft speed, then it would be BIBO stable.)

If a system has a pair of imaginary poles at  $\pm j\omega$ , then it has a resonant frequency of  $\omega$ . If the input also had a pair of imaginary poles at  $\pm j\omega$  then it would excite that resonance and the output would grow without bounds.

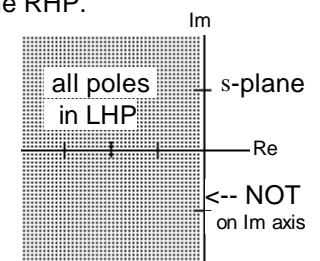

system transfer function poles



### Impulse Response

The Impulse response of a system is the output when the input is an impulse (delta function).

The simplest possible input:  $X(s) = 1$

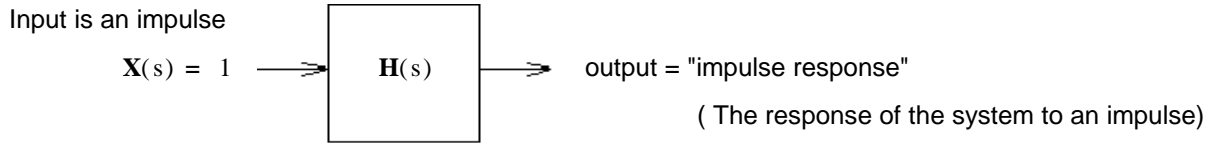

$$Y(s) = X(s) \cdot H(s) = 1 \cdot H(s) = H(s)$$

A signal whose transform is the system's transfer function

Of course, an impulse is a little impractical in real life. But, if you can approximate one, then you may be able to use it to characterize an unknown system.

Sometimes the term "impulse response" is used in place of the term "transfer function"

### Step Responses

The step response of a system is the output when the input is a step (DC which starts at time-zero).

#### Step input

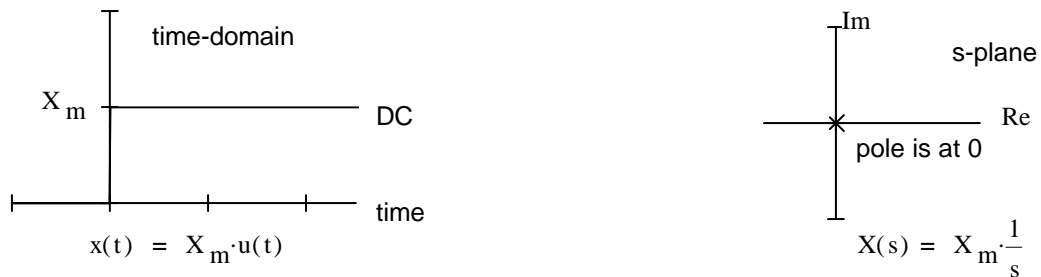

#### System Step Response

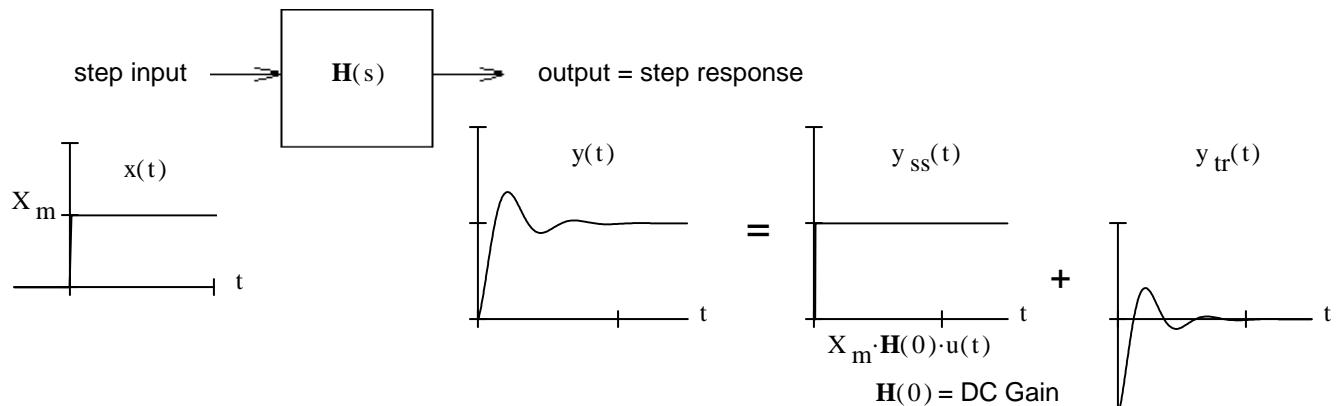

Complete step response = steady-state response + transient response

Steady-State Response & DC Gain

$$Y(s) = X(s) \cdot H(s) = \frac{X_m}{s} \cdot H(s)$$

Complete step response

partial fraction expansion:  $Y(s) = \frac{X_m}{s} \cdot H(s) = \frac{A}{s} + \frac{B}{(s)} + \frac{C}{(s)} + \frac{D}{(s)} + \dots$

steady-state response + transient response

multiply both sides by  $s$   $X_m \cdot H(s) = A + \left[ \frac{B}{(s)} + \frac{C}{(s)} + \frac{D}{(s)} \right] \cdot s$

set  $s := 0$   $X_m \cdot H(0) = A + \left[ \frac{B}{(s)} + \frac{C}{(s)} + \frac{D}{(s)} \right] \cdot 0$

$$Y_{ss}(s) = \frac{A}{s} = \frac{X_m \cdot H(0)}{s} \quad y_{ss}(t) = X_m \cdot H(0) \cdot u(t)$$

$H(0) = \text{DC Gain}$

The **transient part** would be found by finishing the partial-fraction expansion.

Step Response of First-Order Systems

$$H(s) = \frac{k}{s+a} = \frac{k}{s + \frac{1}{\tau}}$$

$$Y(s) = \frac{X_m \cdot k}{s(s+a)}$$

$$y(t) = X_m \cdot \left( \frac{k}{a} - \frac{k}{a} \cdot e^{-at} \right) \cdot u(t) \quad (\text{ignoring initial conditions})$$

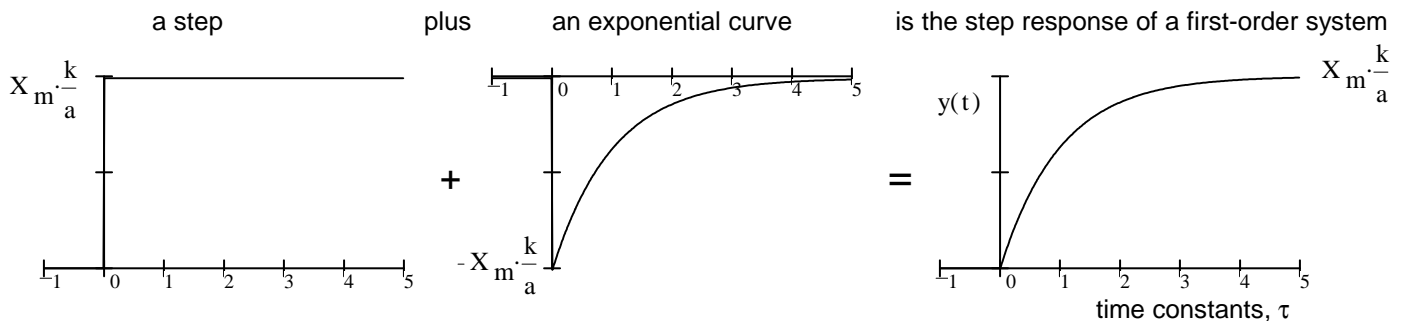

All first-order systems have the same time-domain response:

$$y(t) = y(\infty) + (y(0) - y(\infty)) \cdot e^{-\frac{t}{\tau}}$$

$y(0)$  = the initial condition

$y(\infty)$  = the final condition

A simple example of a first-order system

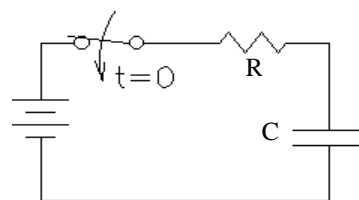

$$v_C(t) = v_C(\infty) + (v_C(0) - v_C(\infty)) \cdot e^{-\frac{t}{\tau}} \quad \tau = R \cdot C$$

# Exponential Curves

Let's take a closer look at some of the characteristics of exponential curves, the output of stable first order system. The transient effects always die out after some time, so the exponents are always negative.

Step response of:  $H(s) = \frac{k}{s + \frac{1}{\tau}}$

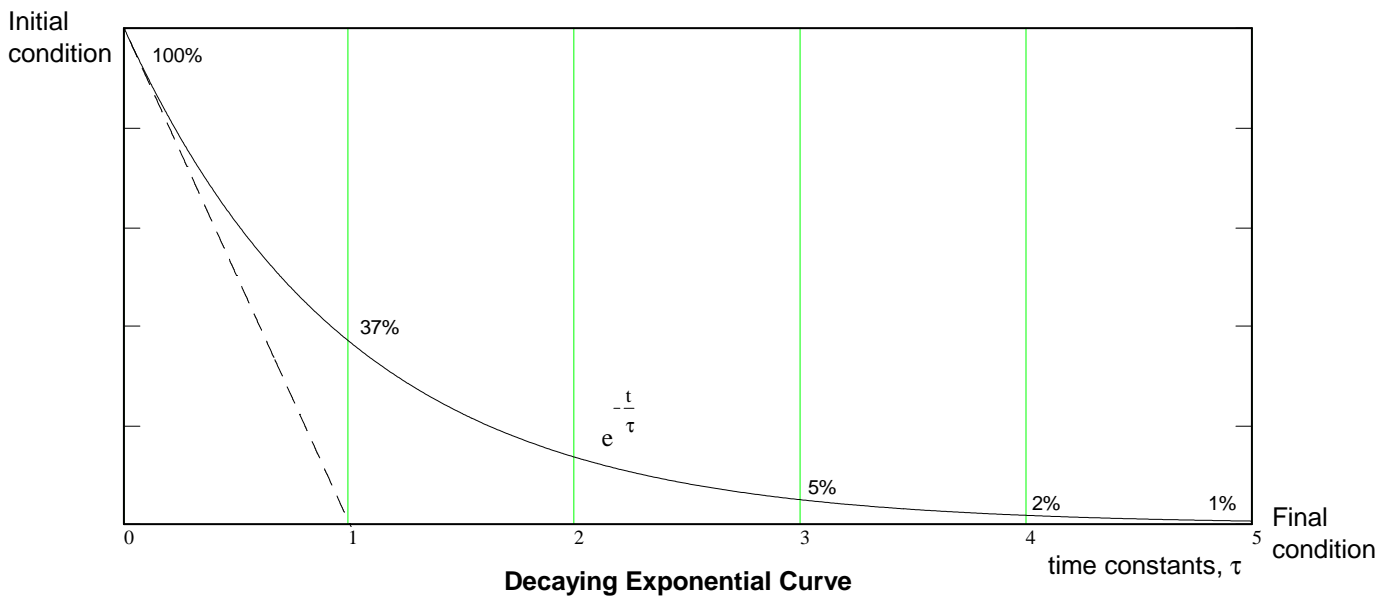
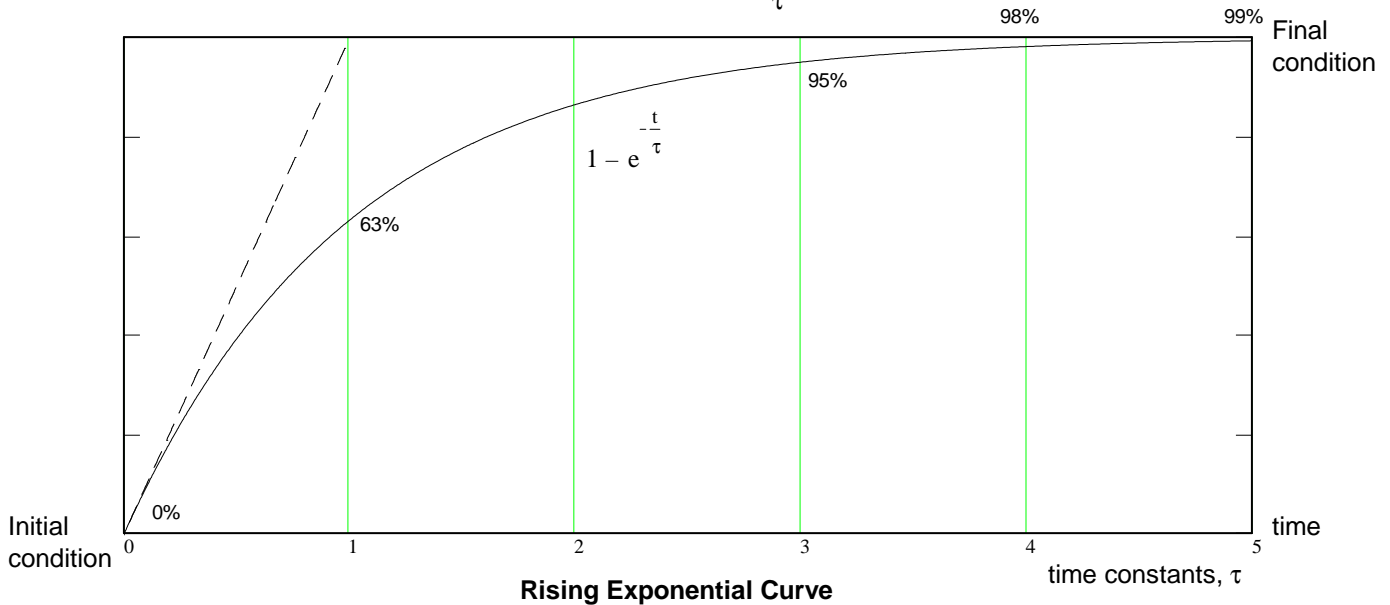

### Some Important Features:

- 1) These curves proceed from an initial condition to a final condition. If the final condition is greater than the initial, then the curve is said to be a "rising" exponential. If the final condition is less than the initial, then the curve is called a "decaying" exponential.
- 2) The curves' initial slope is ± 1/τ. If they continued at this initial slope they'd reach the final condition in one time constant.
- 3) In the first time constant the curve goes 63% from initial to the final condition.
- 4) By four time constants the curve is within 2% of the final condition and is usually considered finished. Mathematically, the curve approaches the final condition asymptotically and never reaches it. In reality, of course, this is nonsense. Whatever difference there may be between the mathematical solution and the final condition will soon be overshadowed by random fluctuations (called noise) in the real system.

## Step Response of Second-Order Systems

### Real poles (over and critically damped)

A first-order system for reference

$$H_1(s) = \frac{k}{s+a} \quad a := 1 \quad k := a \quad y_1(t) := \left( \frac{k}{a} - \frac{k}{a} \cdot e^{-a \cdot t} \right)$$

Second-order system, critically damped

$$H_2(s) = \frac{k}{(s+a)^2} \quad a := 1 \quad k := a^2 \quad y_2(t) := \left( \frac{k}{a^2} - \frac{k}{a^2} \cdot e^{-a \cdot t} - \frac{k}{a} \cdot t \cdot e^{-a \cdot t} \right)$$

double pole on real axis

Second-order system, over damped

$$H_3(s) = \frac{k}{(s+a_1) \cdot (s+a_2)}$$

$$a_1 := a \quad f := 5 \quad a_2 := f \cdot a_1 \quad k := a_1 \cdot a_2 \quad \text{normalization}$$

$$y_3(t) := \left[ \frac{k}{a_1 \cdot a_2} + \frac{k}{a_1 \cdot (a_1 - a_2)} \cdot e^{-a_1 \cdot t} + \frac{k}{a_2 \cdot (a_2 - a_1)} \cdot e^{-a_2 \cdot t} \right]$$

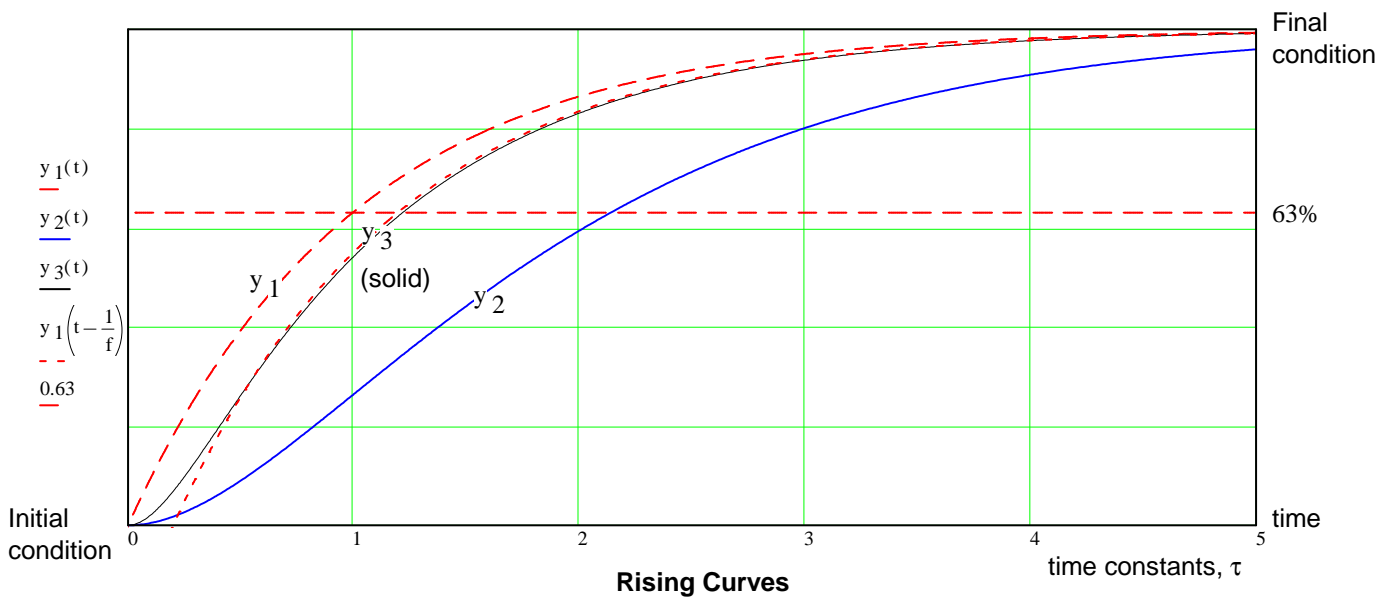

### Some Important Features:

- 1) The poles closest to the  $j\omega$  axis are the **dominant** poles.
- 2) Poles to the left of the dominant poles may introduce an effect that looks like **time delay**.
- 3) Conversely, the effects of a time delay (non-linear) can sometimes be modeled by an extra pole (linear) to the left of the dominant poles.

# Step Responses of Under-Damped 2nd order Systems (Complex poles)

$$H(s) = \frac{k}{s^2 + 2 \cdot a \cdot s + a^2 + b^2} = \frac{k}{\omega_n^2} \cdot \frac{\omega_n^2}{s^2 + 2 \cdot \zeta \cdot \omega_n \cdot s + \omega_n^2}$$

$$\omega_n^2 = a^2 + b^2 \quad \omega_n = \text{natural frequency}$$

DC gain

$$\zeta \cdot \omega_n = a$$

$$H(0) = \frac{k}{a^2 + b^2} = \frac{k}{\omega_n^2}$$

$$\zeta = \frac{a}{\omega_n} = \frac{a}{\sqrt{a^2 + b^2}} = \text{damping factor} = \cos(\theta)$$

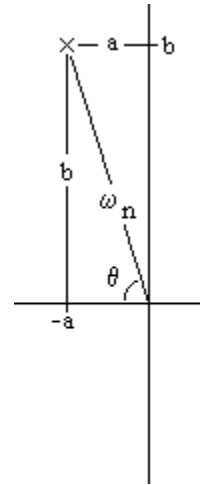

$$y(t) = x_m \cdot H(0) \cdot \left( 1 - e^{-at} \cdot \cos(bt) - \frac{a}{b} \cdot e^{-at} \cdot \sin(bt) \right) \quad (\text{curves below are normalized so } H(0) = 1)$$

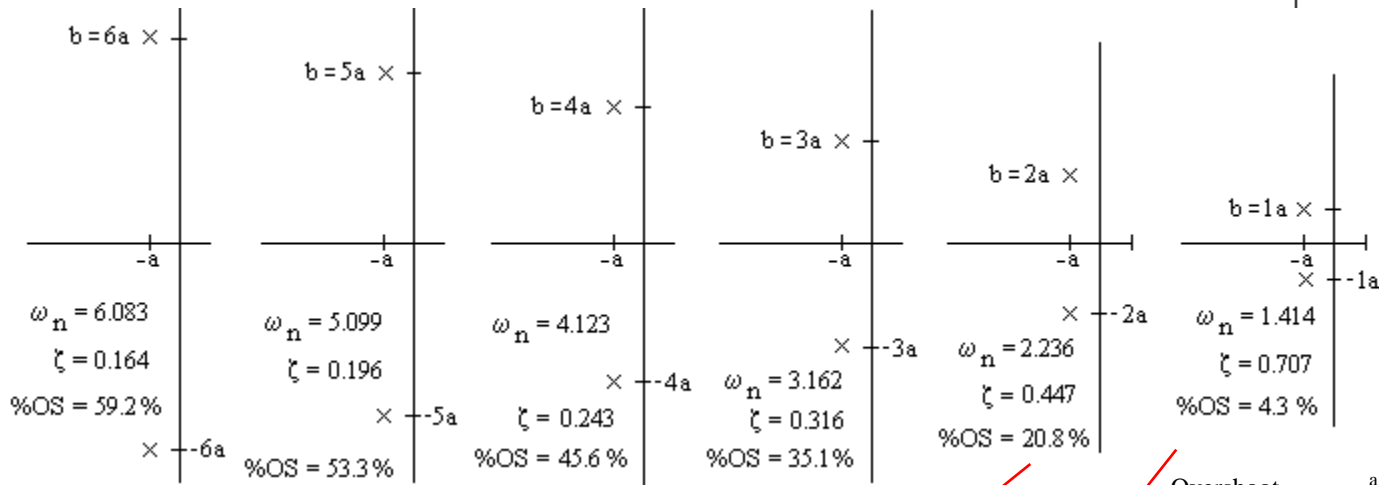

$$\text{Overshoot} \quad \%OS = 100 \cdot e^{-\frac{a}{b} \pi}$$

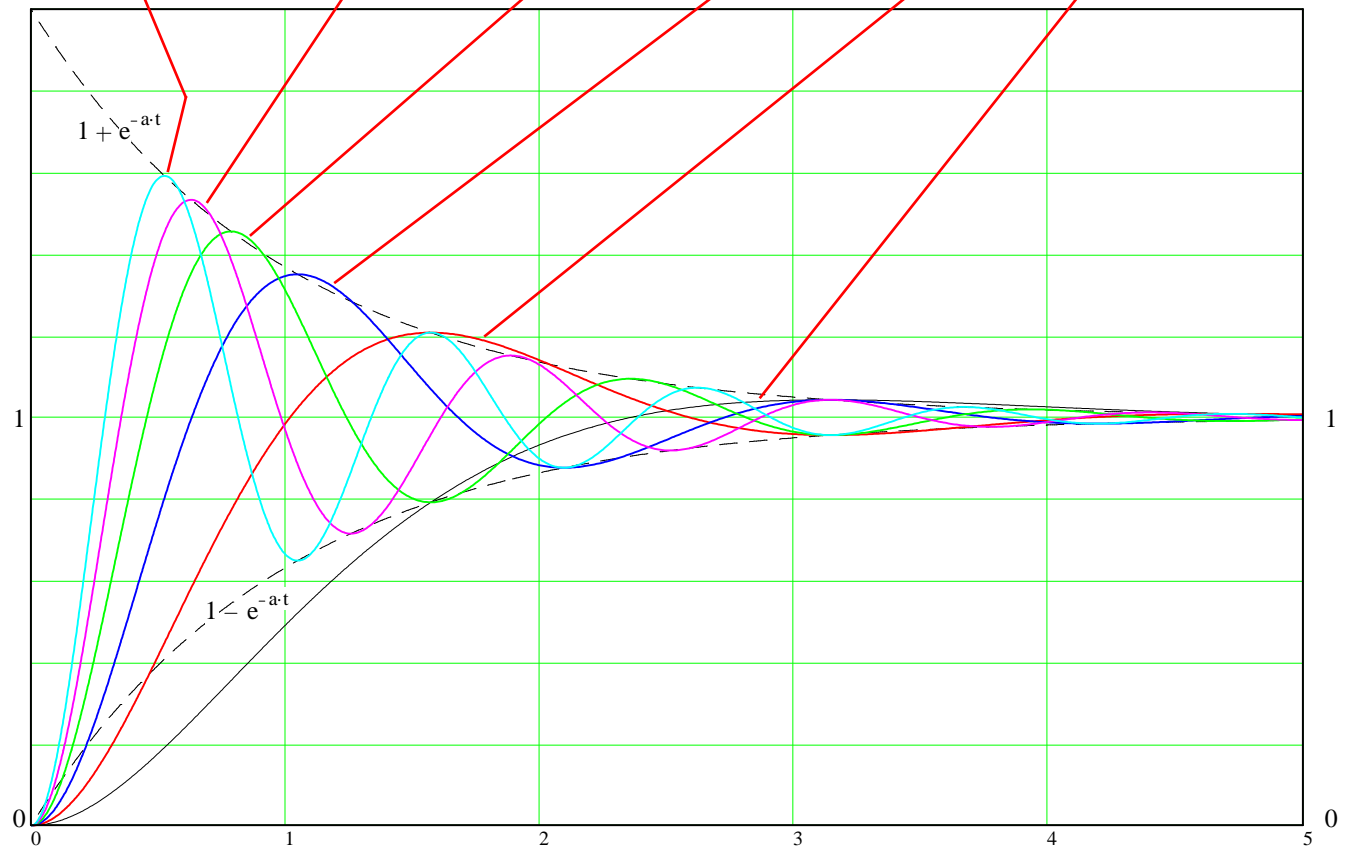

A first-order system for reference

$$H_1(s) = \frac{k}{s+a} \quad a := 1 \quad k := a \quad y_1(t) := \left( \frac{k}{a} - \frac{k}{a} \cdot e^{-a \cdot t} \right)$$

An overdamped system with a single zero

$$H(s) = \frac{k \cdot (s+z)}{(s+a_1) \cdot (s+a_2)} \quad Y(s) = \frac{X_m}{s} \cdot \frac{k \cdot (s+z)}{(s+a_1) \cdot (s+a_2)}$$

k is normalized so the curves below will not reach the same final condition.

$z := 1.6$	$k := \frac{a_1 \cdot a_2}{z}$	$y_4(t) := \left[ \frac{k \cdot z}{a_1 \cdot a_2} + \frac{k \cdot (z - a_1)}{a_1 \cdot (a_1 - a_2)} \cdot e^{-a_1 \cdot t} + \frac{k \cdot (z - a_2)}{a_2 \cdot (a_2 - a_1)} \cdot e^{-a_2 \cdot t} \right]$
$z := 1.2$	$k := \frac{a_1 \cdot a_2}{z}$	$y_5(t) := \left[ \frac{k \cdot z}{a_1 \cdot a_2} + \frac{k \cdot (z - a_1)}{a_1 \cdot (a_1 - a_2)} \cdot e^{-a_1 \cdot t} + \frac{k \cdot (z - a_2)}{a_2 \cdot (a_2 - a_1)} \cdot e^{-a_2 \cdot t} \right]$
$z := 0.8$	$k := \frac{a_1 \cdot a_2}{z}$	$y_6(t) := \left[ \frac{k \cdot z}{a_1 \cdot a_2} + \frac{k \cdot (z - a_1)}{a_1 \cdot (a_1 - a_2)} \cdot e^{-a_1 \cdot t} + \frac{k \cdot (z - a_2)}{a_2 \cdot (a_2 - a_1)} \cdot e^{-a_2 \cdot t} \right]$
$z := 0.6$	$k := \frac{a_1 \cdot a_2}{z}$	$y_7(t) := \left[ \frac{k \cdot z}{a_1 \cdot a_2} + \frac{k \cdot (z - a_1)}{a_1 \cdot (a_1 - a_2)} \cdot e^{-a_1 \cdot t} + \frac{k \cdot (z - a_2)}{a_2 \cdot (a_2 - a_1)} \cdot e^{-a_2 \cdot t} \right]$
$z := -1.6$	$k := \frac{a_1 \cdot a_2}{z}$	$y_8(t) := \left[ \frac{k \cdot z}{a_1 \cdot a_2} + \frac{k \cdot (z - a_1)}{a_1 \cdot (a_1 - a_2)} \cdot e^{-a_1 \cdot t} + \frac{k \cdot (z - a_2)}{a_2 \cdot (a_2 - a_1)} \cdot e^{-a_2 \cdot t} \right]$

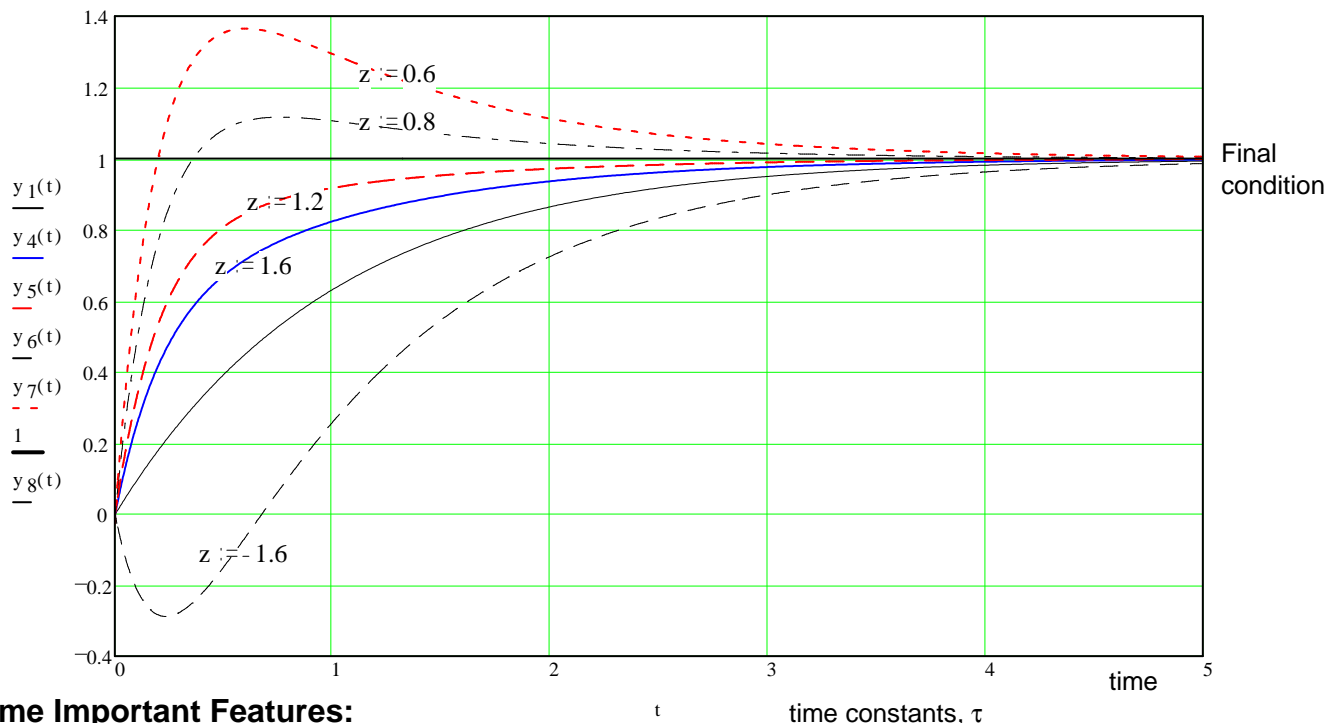

**Some Important Features:**

- 1) The zero (z) is in the LHP if z is positive.
- 2) If the zero is closer to the origin than the poles, than it can cause overshoot and/or significant steady-state error.

**Remember this one**

**3) The steady-state error will be 100% (no DC gain) if the zero is at the origin. The zero is at the origin cancels the pole of the DC (step) input. (The system has a differentiator.)**

- 4) A zero in the RHP (non-minimum phase zero) can cause undershoot or a negative DC gain.

ECE 3510 homework # 5

Due: Wed, 9/14/22

- 1. Problem 3.2b, p.68 in Bodson text.
- 2. Problem 3.3 in Bodson text. As part of your work to reach a solution, draw the pole diagram for each.

3. Find the transfer function  $H(s) = \frac{V_o(s)}{V_i(s)}$  for these circuits. Properly simplify all your expressions for  $H(s)$  like you did in HW 4.

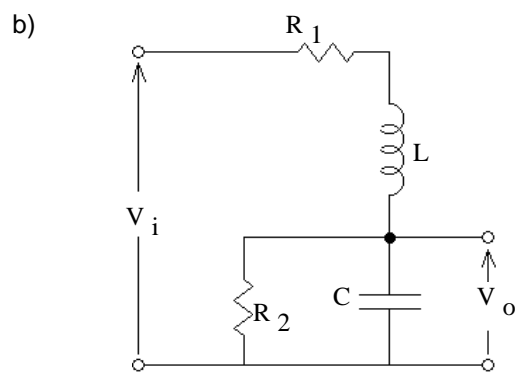
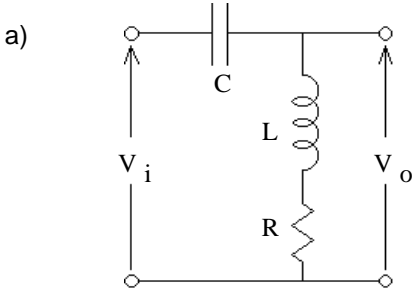

4. Find the step response of:  $H(s) = \frac{k}{(s+a_1)(s+a_2)}$  Step input:  $x(t) = x_m \cdot u(t)$

$$X(s) = \frac{x_m}{s}$$

Show the steps necessary to arrive at the steady-state and transient responses shown as equation(s) 3.37 on p.49 of the text.

5. Find the step response of:  $H(s) = \frac{k \cdot s}{(s+a)^2 + b^2} = \frac{k \cdot s}{s^2 + 2 \cdot s \cdot a + (a^2 + b^2)}$  where b is real

Show the steps necessary to arrive at the steady-state and transient responses.

6. For the transfer functions below, find the DC gain and the full step responses. You may use the results found in section 3.3.2 of the text as well as problem 3, above.

a)  $H(s) = \frac{2}{s^2 + 2 \cdot s + 1}$

b)  $H(s) = \frac{-s-2}{s^2 + 2 \cdot s + 2}$

Hint: Notice how easily this will split into two parts that you already have answers for.

**Answers**

1.  $\frac{H_1 \cdot H_4 + H_2 \cdot H_4 - H_1 \cdot H_2 \cdot H_3 + H_1 \cdot H_3}{1 + H_1}$

2. Stable

Example of a Problem input

- a) yes
- b) no
- c) yes
- d) no
- e) no
- f) no

cos(2-t)  
any input, even noise  
1 DC  
1 u(t) is assumed

3. a)  $\frac{s^2 + \frac{R}{L} \cdot s}{s^2 + \frac{R}{L} \cdot s + \frac{1}{LC}}$

b)  $\frac{1}{LC} \cdot \frac{1}{s^2 + \left(\frac{1}{C \cdot R_2} + \frac{R_1}{L}\right) \cdot s + \left(1 + \frac{R_1}{R_2}\right) \cdot \frac{1}{LC}}$

4.  $y(\infty) = \frac{x_m \cdot k}{a_1 \cdot a_2}$

$y_{tr}(t) = x_m \cdot \left[ \frac{k}{a_1 \cdot (a_1 - a_2)} \cdot e^{-a_1 \cdot t} + \frac{k}{a_2 \cdot (a_2 - a_1)} \cdot e^{-a_2 \cdot t} \right]$

OR:  $y(t) = x_m \cdot \left[ \frac{k}{a_1 \cdot a_2} + \frac{k}{a_1 \cdot (a_1 - a_2)} \cdot e^{-a_1 \cdot t} + \frac{k}{a_2 \cdot (a_2 - a_1)} \cdot e^{-a_2 \cdot t} \right]$

5.  $y(\infty) = 0$   $y_{tr}(t) = x_m \cdot \frac{k}{b} \cdot e^{-a \cdot t} \cdot \sin(b \cdot t)$  OR:  $y(t) = 0 + x_m \cdot \frac{k}{b} \cdot e^{-a \cdot t} \cdot \sin(b \cdot t)$

6. a)  $x_m \cdot (2 - 2 \cdot e^{-t} - 2 \cdot t \cdot e^{-t})$  b)  $x_m \cdot (-1 + e^{-t} \cdot \cos(t))$

- Convert the following complex numbers to polar form ( $m/\theta$  or  $me^{j\theta}$ ). a)  $2.6 + 8.7j$  b)  $3 + 4j$  c)  $-3 - 4j$
- Convert the following complex numbers to rectangular form ( $a + bj$ ). a)  $10 \cdot e^{j \cdot 60 \cdot \text{deg}}$  b)  $10 \cdot e^{-j \cdot 45 \cdot \text{deg}}$  c)  $20 \cdot e^{j \cdot 120 \cdot \text{deg}}$
- Add or subtract the complex numbers. a)  $(3 + 2j) + (6 + 9j)$  b)  $(9 - 10j) - (9 + 10j)$
- Multiply the complex numbers. a)  $(20 \cdot e^{j \cdot 40 \cdot \text{deg}}) \cdot (10 \cdot e^{j \cdot 60 \cdot \text{deg}})$  b)  $(-2 - j) \cdot (-6 - 9j)$
- Divide the complex numbers. a)  $\frac{20 \cdot e^{j \cdot 40 \cdot \text{deg}}}{10 \cdot e^{j \cdot 60 \cdot \text{deg}}}$  b)  $\frac{12 + 10j}{6 + 9j}$
- Add and subtract the sinusoidal voltages using phasors. Draw a phasor diagram which shows all 4 phasors, and give your final answer in time domain form.

$$v_1(t) = 1.5 \cdot V \cdot \cos(\omega \cdot t + 10 \cdot \text{deg})$$

$$v_2(t) = 3.2 \cdot V \cdot \cos(\omega \cdot t + 25 \cdot \text{deg})$$

a) Find  $v_3(t) = v_1(t) + v_2(t)$

b) Find  $v_4(t) = v_1(t) - v_2(t)$

7. a) Find  $Z_{\text{eq}}$ .

- b) Find the current  $I_L(j\omega)$ .

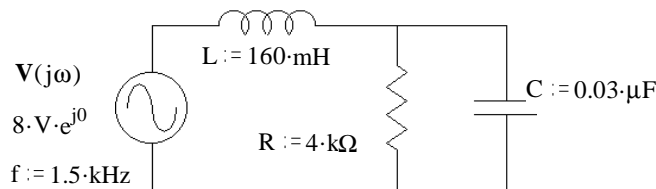

8. Find the steady-state magnitude and phase of each of the following transfer functions.  $|H(j\omega)| = ?$   $\angle H(j\omega) = ?$

a)

$$\omega := 10 \cdot \frac{\text{rad}}{\text{sec}} \quad H(s) = \frac{40 \cdot s}{s^2 + \frac{10}{\text{sec}} \cdot s + \frac{200}{\text{sec}^2}}$$

b)

$$f := 50 \cdot \text{Hz} \quad H(s) = \frac{s^2 + \frac{1000}{\text{sec}} \cdot s}{s^2 + \frac{300}{\text{sec}} \cdot s + \frac{10000}{\text{sec}^2}}$$

9. Find the following outputs. Express them in the time domain, first as a cosine with a phase angle and then as a sum of cosine and sine with no phase angles:

a) The input  $x(t) = 3 \cdot \cos(10 \cdot t)$  is the input for the transfer function of 8a), above.

b) The input  $x(t) = 5 \cdot \sin(2 \cdot \pi \cdot 50 \cdot t)$  is the input for the transfer function of 8b), above.

remember, sine is -j

### Answers

1. a)  $9.08 \cdot e^{j \cdot 73.4 \cdot \text{deg}}$  b)  $5 \cdot e^{j \cdot 53.1 \cdot \text{deg}}$  c)  $5 \cdot e^{-j \cdot 126.9 \cdot \text{deg}}$

2. a)  $5 + 8.66 \cdot j$  b)  $7.071 - 7.071 \cdot j$  c)  $-10 + 17.321 \cdot j$

3. a)  $9 + 11 \cdot j$  b)  $-20 \cdot j$

4. a)  $200 \cdot e^{j \cdot 100 \cdot \text{deg}}$  b)  $24.2 \cdot e^{j \cdot 82.9 \cdot \text{deg}}$

5. a)  $2 \cdot e^{-j \cdot 20 \cdot \text{deg}}$  b)  $1.385 - 0.41 \cdot j$

6. a)  $v_1(t) + v_2(t) = 4.67 \cdot \cos(\omega \cdot t + 20.2 \cdot \text{deg}) \cdot V$

b)  $v_1(t) - v_2(t) = 1.794 \cdot \cos(\omega \cdot t - 142.5 \cdot \text{deg}) \cdot V$

7. a)  $1.82 \cdot \text{k}\Omega - 15.2 \cdot \text{deg}$

b)  $4.4 \cdot \text{mA} \quad 15.2 \cdot \text{deg}$

8. a)  $M = 2.828 \quad 45 \cdot \text{deg}$  b)  $M = 2.544 \quad -25.8 \cdot \text{deg}$

9. a)  $y(t) = 8.484 \cdot \cos\left(10 \cdot \frac{\text{rad}}{\text{sec}} \cdot t + 45 \cdot \text{deg}\right) = 6 \cdot \cos\left(10 \cdot \frac{\text{rad}}{\text{sec}} \cdot t\right) - 6 \cdot \sin\left(10 \cdot \frac{\text{rad}}{\text{sec}} \cdot t\right)$

b)  $y(t) = 12.72 \cdot \cos(2 \cdot \pi \cdot 50 \cdot t - 115.82 \cdot \text{deg}) = -5.54 \cdot \cos(2 \cdot \pi \cdot 50 \cdot t) + 11.45 \cdot \sin(2 \cdot \pi \cdot 50 \cdot t)$