

Syllabus.

Supplemental example and problem sessions will make this class much easier.

But it's still a 4-hour engineering class. How can you survive??

1. Easiest way to get through school is to actually learn and try to retain what you are asked to learn.

Even if you're too busy, don't lose your good study practices.
What you "just get by" on today will cost you later.

Don't fall for the "I'll never need to know this" trap. Sure, much of what you learn you may not use, but some you will need, either in the current class, or future classes, or maybe sometime in your career. Don't waste time second-guessing the curriculum, It'll still be easier to just do your best to learn and retain.

2. Don't fall for the "traps".

Homework answers, Problem session solutions, Posted solutions, Lecture notes.

3. KEEP UP! Use calendar.

4. Make "permanent notes" after you've finished a subject or section and feel that you know it.

Signals (INFORMATION !!)

For us: A time-varying voltage or current that carries information.

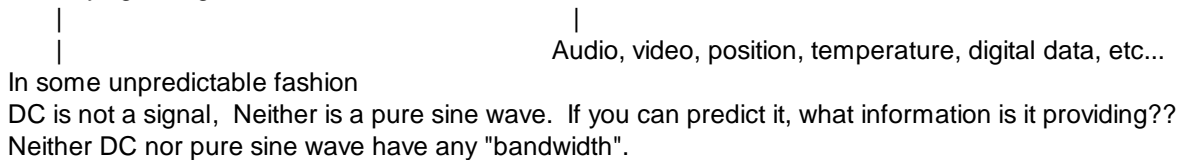

Recall Fourier series: Any periodic waveform can be represented by a series of sinewaves of different frequencies.

Blocks and block diagrams (acting on signals) (information))

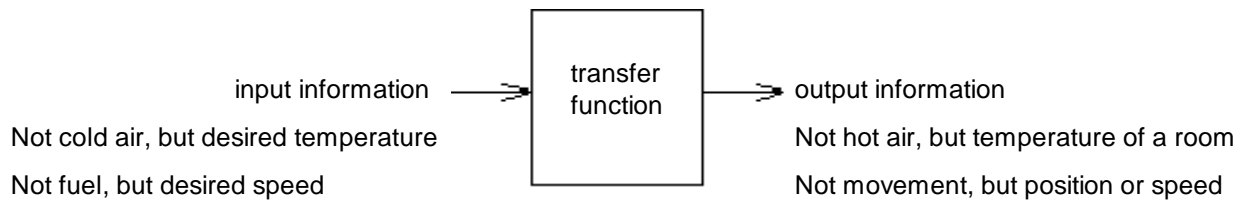

These blocks DO NOT show the flow of materials, power, or energy needed to act upon the information. For example, the input to a block might be the position of the gas pedal in your car and the output might be the car's speed. The energy input required is not shown and neither are the fuel and air moving through the engine. Although they are very important engineering concerns, we will not be considering those things in this class.

If possible we'd like to work with the blocks in a very simple mathematical way:

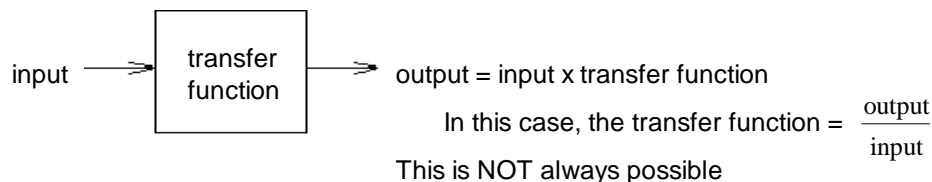

Blocks can be "hooked" together, that is, the output of one block could be the input to another

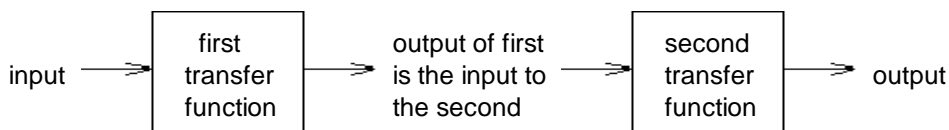

Blocks can be hooked together in more complex ways like this loop. This is an example "feedback".

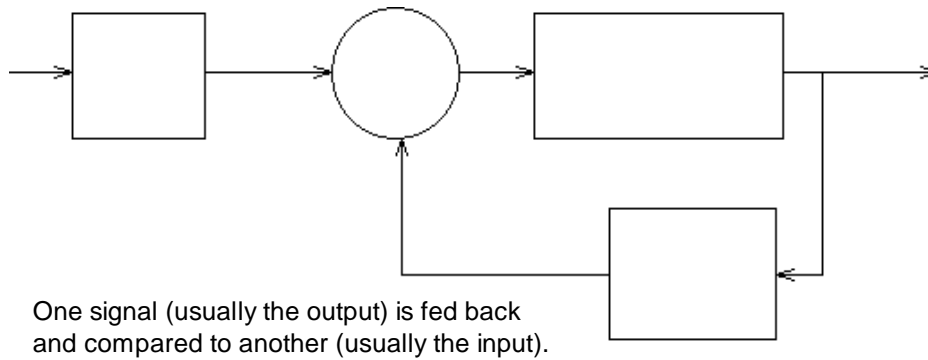

Example of a System (A Position Servo with Feedback)

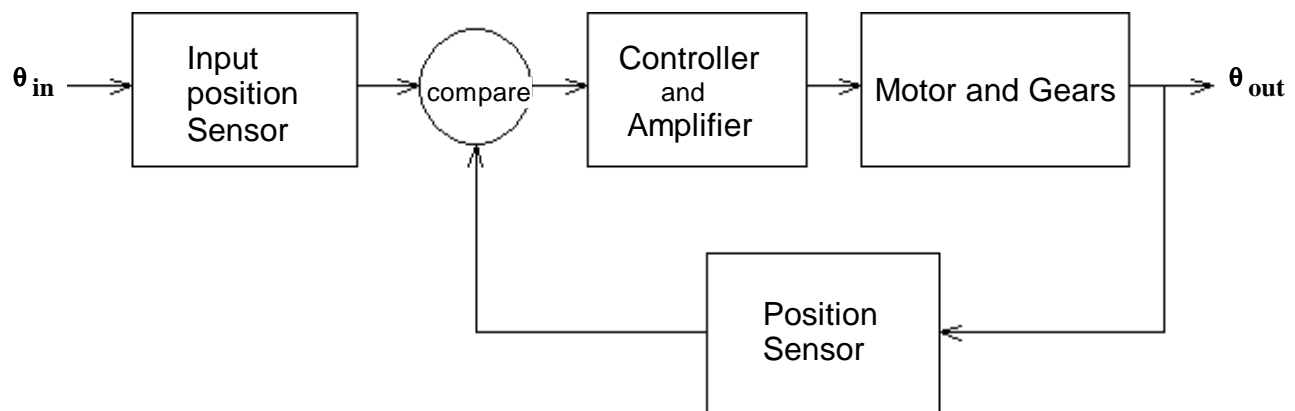

Again, the lines represent signals. Yes, there may also be considerable power moving from one block to another or out the end, but that's not what we'll care about here. All we really care about here is the basic information.

Blocks represent subsystems, devices or components which act upon an input or inputs to produce an output.

We will want a **mathematical** way to represent the signals and the action of the blocks so that we can get a better handle on what's happening, and, hopefully, make the whole system work as we want.

We'll assume that each of the blocks is linear and time invariant. Anything else gets too hard too fast, and this is a good place to start. Many real devices can be modeled as linear and time invariant, at least over some region of operation.

For linear systems, where the signals and systems can be represented by Laplace transforms:

$$\begin{array}{c}
 \mathbf{X}_{in}(s) \longrightarrow \boxed{\mathbf{H}(s)} \longrightarrow \mathbf{X}_{out}(s) = \mathbf{X}_{in}(s) \cdot \mathbf{H}(s) \\
 \text{Transfer function: } \mathbf{H}(s) = \frac{\mathbf{X}_{out}(s)}{\mathbf{X}_{in}(s)}
 \end{array}$$

\mathbf{X}_{in} and \mathbf{X}_{out} could be anything from small electrical signals to powerful mechanical motions or forces.

The variable "s" comes from Laplace transformations.

We will come back to this and spend a LOT more time on Laplace transforms and transfer functions

Yesterday we drew a block diagram on the board. Let's examine those blocks a little more closely

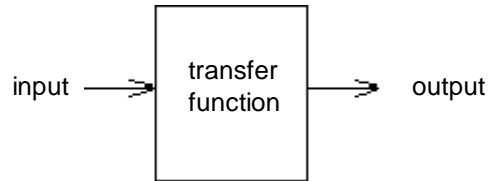

What's inside?

How are the input and output related? If you know the input, how do you find the output? Sometimes we can just multiply the input by the expression in the box to get the output. Then the expression in the box is called a transfer function.

In that case, the transfer function = $\frac{\text{output}}{\text{input}}$

A very simple case, a potentiometer

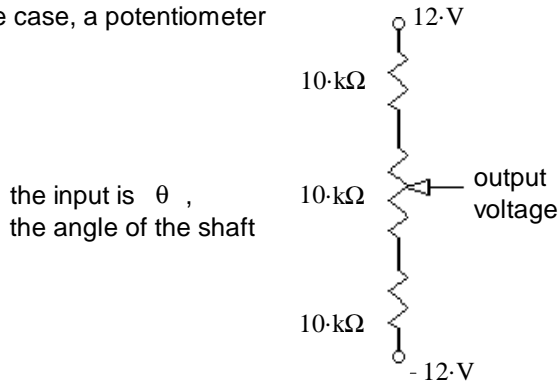

We measure the voltage over its range of motion to find K_p .

$$K_p = \frac{\text{output}}{\text{input}} = \frac{4 \cdot \text{V} - -4 \cdot \text{V}}{270 \cdot \text{deg}} = 29.63 \cdot \frac{\text{mV}}{\text{deg}} = 1.7 \cdot \frac{\text{V}}{\text{rad}}$$

In this case, "zero" must be in the center of the range of motion

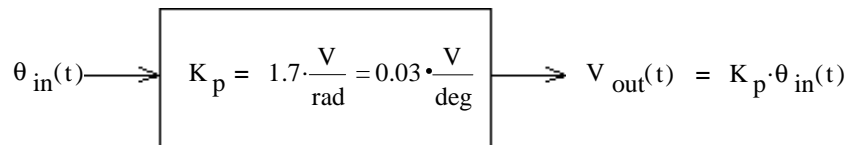

Nice... too bad it works for so few things in the time domain! Simple voltage dividers, amplifiers, and not much else. All real electrical systems also have inductors and capacitors.

$$\frac{1}{L} \int v_L dt = i_L \quad v_L = L \frac{d}{dt} i_L$$

$$i_C = C \frac{d}{dt} v_C \quad v_C = \frac{1}{C} \int i_C dt$$

We'll have to avoid capacitors and inductors-- they're too complicated... You can't just multiply when there are differentials involved

How about the mechanical world? $F = ma$, Great, no differentials... uh, except... $F = m \cdot a = m \cdot \frac{d}{dt} v = m \cdot \frac{d^2}{dt^2} x$

And then there are springs: $F = k \cdot x = k \cdot \int v dt = k \cdot \int \int a dt dt$

Isn't there some way that we could possibly replace all this differentiation and integration with multiplication and division?

Laplace transforms $\frac{d}{dt}$ operation can be replaced with s , and $\int dt$ can be replaced by $\frac{1}{s}$

Then...

$$v_L = L \frac{d}{dt} i_L \quad \mathbf{V}_L(s) = L \cdot s \cdot \mathbf{I}_L(s)$$

$$v_C = \frac{1}{C} \int i_C dt \quad \mathbf{V}_C(s) = \frac{1}{C} \cdot \frac{1}{s} \cdot \mathbf{I}_C(s) \quad \mathbf{Z}_C = \frac{1}{C \cdot s}$$

Inductive impedance: $\mathbf{Z}_L = L \cdot s$

ECE 3510 Lecture 2 notes p2

Recall from your Ordinary Differential Equations class, the Laplace transform method of solving differential equations. The Laplace transform allowed you to change time-domain functions to frequency-domain functions.

1) Transform your signals into the frequency domain with the Laplace transform.

$$F(s) = \int_0^{\infty} f(t) \cdot e^{-s \cdot t} dt \quad \text{Unilateral Laplace transform}$$

2) Solve your differential equations with plain old algebra, where:

$$\frac{d}{dt} \text{ operation can be replaced with } s, \quad \text{and} \quad \int \cdot dt \text{ can be replaced by } \frac{1}{s}$$

3) Transform your result back to the time domain with the inverse Laplace transform.

$$f(t) = \frac{1}{2 \cdot \pi \cdot j} \cdot \int_{c-j\infty}^{c+j\infty} F(s) \cdot e^{s \cdot t} ds$$

OK, truth be told, we never actually use the inverse Laplace transform. We use tables instead.

Then our nice, linear, blocks could contain Laplace transfer functions, like this:

Consider a circuit:

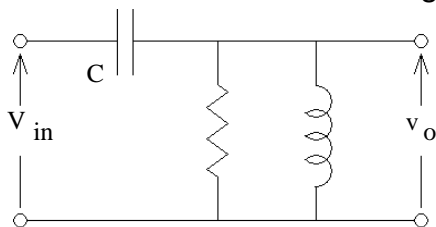

Using the impedances in a voltage divider:

$$H(s) = \frac{V_o(s)}{V_{in}(s)} = \frac{\frac{1}{\frac{1}{R} + \frac{1}{L \cdot s}}}{\frac{1}{\frac{1}{R} + \frac{1}{L \cdot s}} + \frac{1}{C \cdot s}} = \frac{1}{1 + \frac{1}{C \cdot s \cdot R} + \frac{1}{C \cdot s \cdot L \cdot s}} \cdot \frac{(s^2)}{(s^2)}$$

$$= \frac{s^2}{s^2 + \frac{1}{C \cdot R} \cdot s + \frac{1}{C \cdot L}}$$

This could now be represented as a block operator:

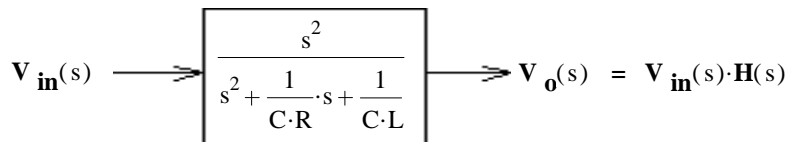

Transfer functions can be written for all kinds of devices and systems, not just electric circuits and the input and output do not have to be similar. For instance, the potentiometers used to measure angular position in the servo have an angle as input and a voltage as output.

Laplace transforms will be important!!

BUT, remember, the first step is to transform the signals into the frequency domain with the Laplace transform. Maybe we ought to deal with the signals first...

FIRST: Laplace transforms of signals

Let's evaluate some of these and see if we can make a table

Ex. 1 $f(t) = \delta(t)$ The Impulse or "Dirac" function, not a very likely signal in real life.

$$F(s) = \int_0^{\infty} \delta(t) \cdot e^{-s \cdot t} dt \quad \text{but: } \delta(t) \cdot g(t) = \delta(t) \cdot g(0) \quad \text{so:}$$

$$= \int_0^{\infty} \delta(t) \cdot e^{-s \cdot 0} dt = \int_0^{\infty} \delta(t) \cdot 1 dt = 1$$

Ex. 2 $f(t) = u(t)$ The unit-step function, a constant value (DC) signal

$$F(s) = \int_0^{\infty} u(t) \cdot e^{-s \cdot t} dt \quad \text{but:} \quad u(t) = 1 \quad \text{from } 0 \text{ to } \infty$$

$$= \int_0^{\infty} 1 \cdot e^{-s \cdot t} dt = \frac{1}{-s} \cdot e^{-s \cdot t} \Big|_0^{\infty} = \frac{1}{-s} \cdot e^{-s \cdot \infty} - \frac{1}{-s} \cdot e^{-s \cdot 0} = 0 - \frac{1}{-s} \cdot (1) = \frac{1}{s}$$

if $s > 0$

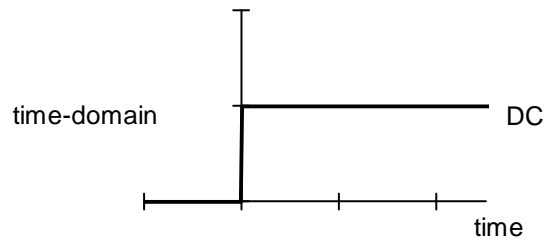
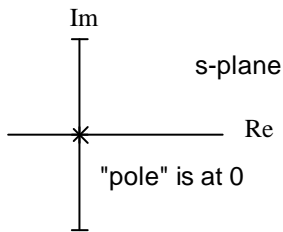

Ex. 3 $f(t) = u(t) \cdot e^{at}$

$$F(s) = \int_0^{\infty} e^{at} \cdot e^{-s \cdot t} dt = \int_0^{\infty} e^{(a-s) \cdot t} dt = \frac{1}{(a-s)} \cdot e^{(a-s) \cdot t} \Big|_0^{\infty}$$

$$= \frac{1}{(a-s)} \cdot e^{(a-s) \cdot \infty} - \frac{1}{(a-s)} \cdot e^{(a-s) \cdot 0} = 0 - \frac{1}{(a-s)} \cdot (1) = \frac{1}{s-a}$$

if $s > a$ "pole" is at +a

for positive a values

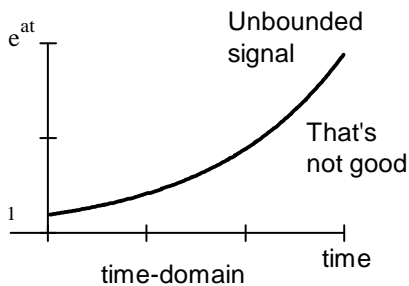
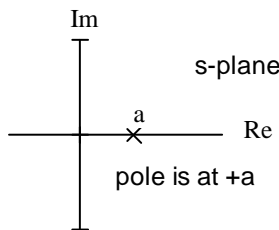

for negative a values

$$\frac{A}{s-a}$$

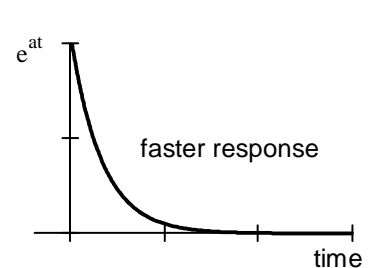
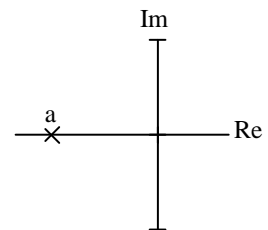
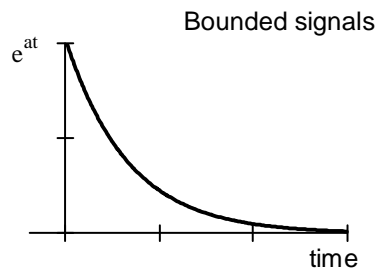
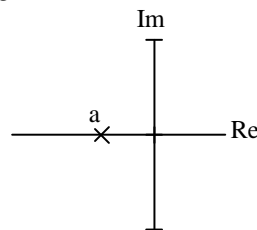

This is the single most-important Laplace transform case. In fact we really don't need any others. Ex.1 can be thought of as this case with $a = -\infty$. Ex. 2 can be thought of as $a = 0$. And finally, all sinusoids can be made from exponentials if you let the poles (a) be complex. Remember Euler's equations...

Euler's equations $e^{j \cdot \omega \cdot t} = \cos(\omega t) + j \cdot \sin(\omega t)$

$e^{(\alpha + j \cdot \omega) \cdot t} = e^{\alpha \cdot t} \cdot (\cos(\omega t) + j \cdot \sin(\omega t))$

Pole Location(s) correspond to the type of signal.

ECE 3510 Lecture 2 notes p4

Euler's equations $\cos(\omega \cdot t) = \frac{e^{j\omega \cdot t} + e^{-j\omega \cdot t}}{2}$

$\sin(\omega \cdot t) = \frac{e^{j\omega \cdot t} - e^{-j\omega \cdot t}}{2 \cdot j}$

Ex. 4 $f(t) = u(t) \cdot \cos(\omega \cdot t)$

$$\begin{aligned}
 F(s) &= \int_0^{\infty} \cos(\omega \cdot t) \cdot e^{-s \cdot t} dt = \int_0^{\infty} \left(\frac{e^{j\omega \cdot t} + e^{-j\omega \cdot t}}{2} \right) \cdot e^{-s \cdot t} dt = \int_0^{\infty} \frac{e^{(j\omega - s) \cdot t} + e^{-(j\omega + s) \cdot t}}{2} dt \\
 &= \frac{1}{2} \int_0^{\infty} e^{(j\omega - s) \cdot t} dt + \frac{1}{2} \int_0^{\infty} e^{-(j\omega + s) \cdot t} dt \\
 &= \frac{1}{2} \left[\frac{1}{j\omega - s} \right] \cdot e^{(j\omega - s) \cdot t} \Bigg|_0^{\infty} + \frac{1}{2} \left[\frac{1}{-(j\omega + s)} \right] \cdot e^{-(j\omega + s) \cdot t} \Bigg|_0^{\infty} \\
 &= 0 - \frac{1}{2} \left[\frac{1}{j\omega - s} \right] \cdot (1) + 0 - \frac{1}{2} \left[\frac{1}{-(j\omega + s)} \right] \cdot (1) = \frac{-1}{-2 \cdot j\omega - 2 \cdot s} + \frac{-1}{2 \cdot j\omega - 2 \cdot s} \\
 &= \frac{1}{2 \cdot j\omega + 2 \cdot s} + \frac{-1}{2 \cdot j\omega - 2 \cdot s} = \frac{(2 \cdot j\omega - 2 \cdot s) - (2 \cdot j\omega + 2 \cdot s)}{(2 \cdot j\omega + 2 \cdot s) \cdot (2 \cdot j\omega - 2 \cdot s)} \\
 &= \frac{-4 \cdot s}{(2 \cdot j\omega + 2 \cdot s) \cdot (2 \cdot j\omega - 2 \cdot s)} = \frac{-4 \cdot s}{4 \cdot j^2 \cdot \omega^2 - 4 \cdot s^2} = \frac{-s}{-\omega^2 - s^2} = \frac{s}{\omega^2 + s^2}
 \end{aligned}$$

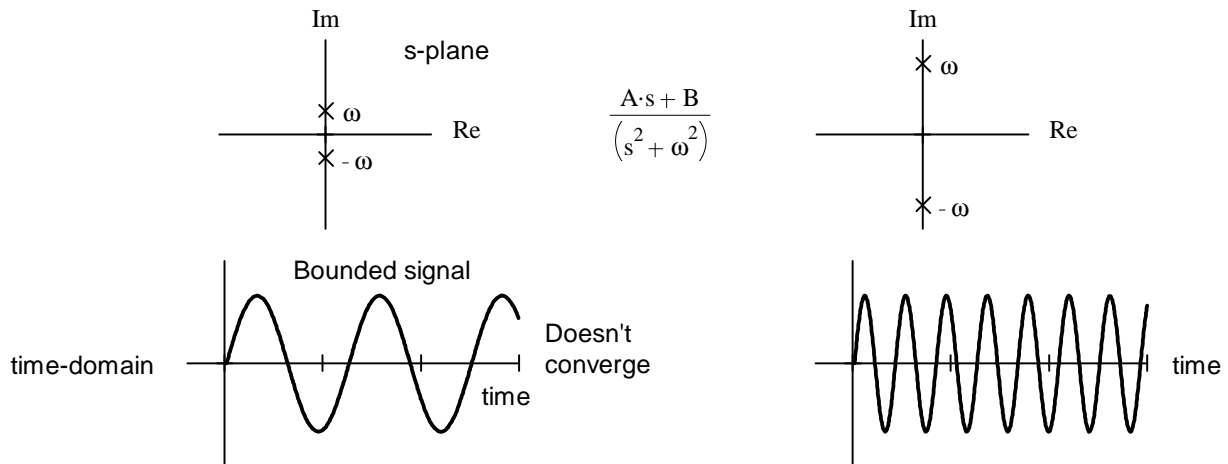

What if the poles have a real component?

$f(t) = u(t) \cdot e^{\alpha \cdot t} \cdot \sin(\omega \cdot t)$

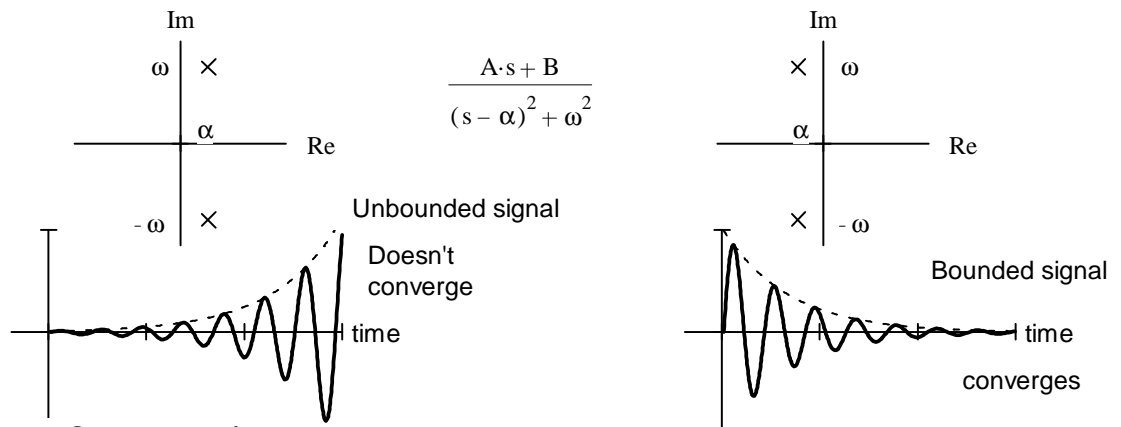

Ex. 5 Multiply by time property

$$f(t) = u(t) \cdot t \cdot e^{-at} \quad F(s) = \int_0^{\infty} t \cdot e^{-at} \cdot e^{-s \cdot t} dt = \int_0^{\infty} t \cdot e^{-(a-s) \cdot t} dt$$

Remember integration by parts:

$$\int h(t) \cdot \frac{d}{dt} g(t) dt = h(t) \cdot g(t) - \int g(t) \cdot \frac{d}{dt} h(t) dt$$

choose: $h(t) = t$ from which: $\frac{d}{dt} h(t) = 1$

and: $\frac{d}{dt} g(t) = e^{-(a-s) \cdot t}$ from which: $g(t) = \int e^{-(a-s) \cdot t} dt = \frac{e^{-(a-s) \cdot t}}{(a-s)}$

$$F(s) = \int_0^{\infty} t \cdot e^{-(a-s) \cdot t} dt = t \cdot \frac{e^{-(a-s) \cdot t}}{(a-s)} \Big|_0^{\infty} - \int_0^{\infty} \frac{e^{-(a-s) \cdot t}}{(a-s)} \cdot (1) dt = t \cdot \frac{e^{-(a-s) \cdot t}}{(a-s)} \Big|_0^{\infty} - \frac{e^{-(a-s) \cdot t}}{(a-s)^2} \Big|_0^{\infty}$$

$$= 0 - 0 - \left[0 - \frac{1}{(a-s)^2} \right] = \frac{1}{(a-s)^2} = \frac{1}{(s-a)^2}$$

The easy way:

Use the "multiplication by time" property # 5 on p.8 of the Bodson textbook

$$t \cdot x(t) \iff -\frac{d}{ds} X(s)$$

$$t \cdot e^{-at} \iff -\frac{d}{ds} \left(\frac{1}{s-a} \right) = -\frac{d}{ds} [(s-a)^{-1}] = -\frac{1}{-1} \cdot \frac{1}{(s-a)^2} \cdot \left[\frac{d}{ds} (s-a) \right] = \frac{1}{(s-a)^2} \cdot 1 = \frac{1}{(s-a)^2}$$

Anything that works for exponentials also works for sines and cosines...

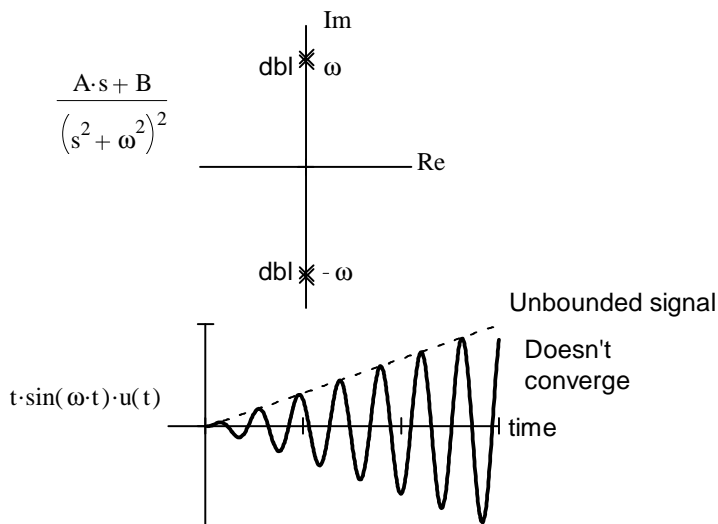

And "DC" too...

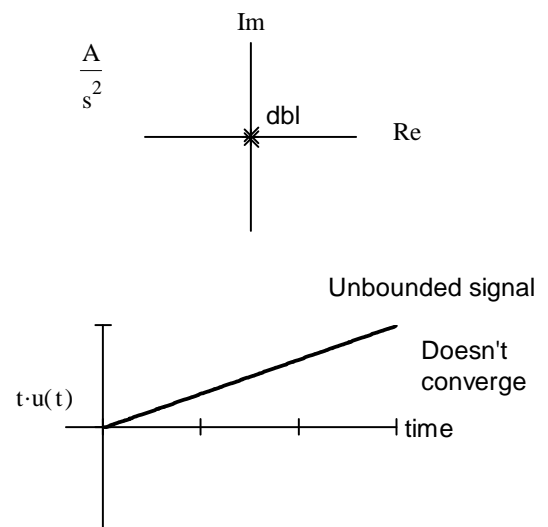

Signal Type, Boundedness, and Convergence can be predicted from the poles

Poles in the Open-Left-Half-Plane (OLHP) Real part of pole is negative $\text{Re}(s_p) < 0$

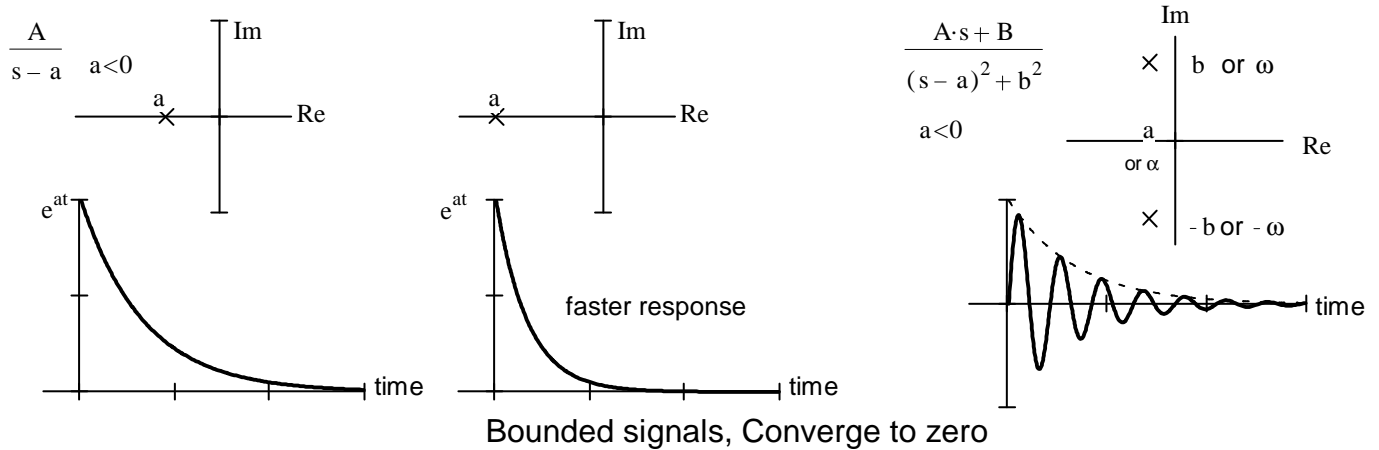

Single Poles on Imaginary Axis Real part of pole is zero $\text{Re}(s_p) = 0$

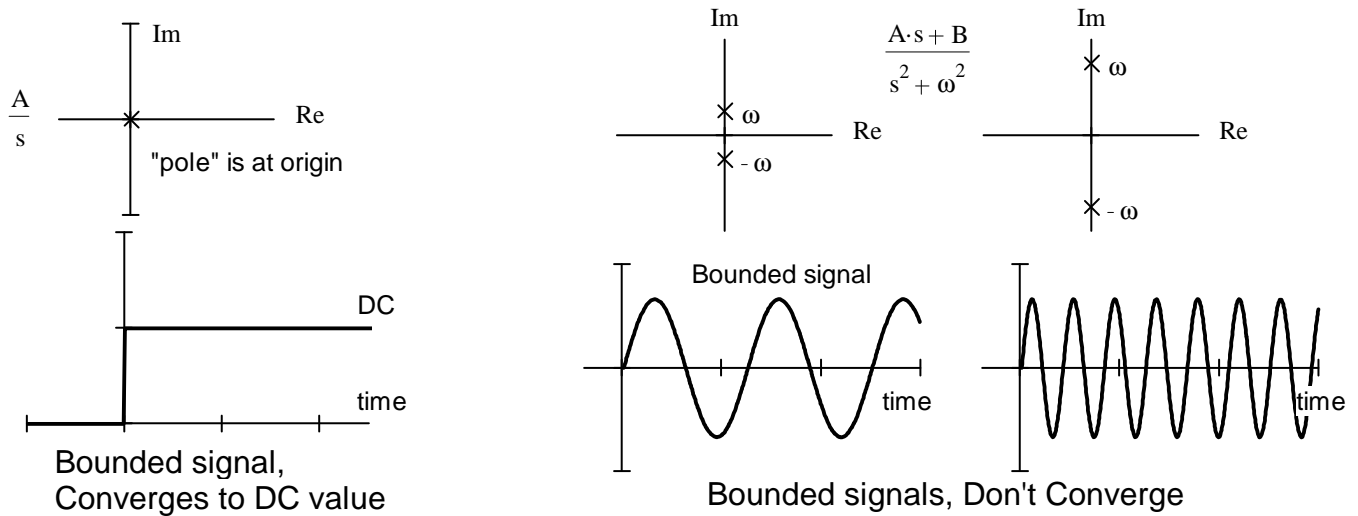

Double Poles on Imaginary Axis or

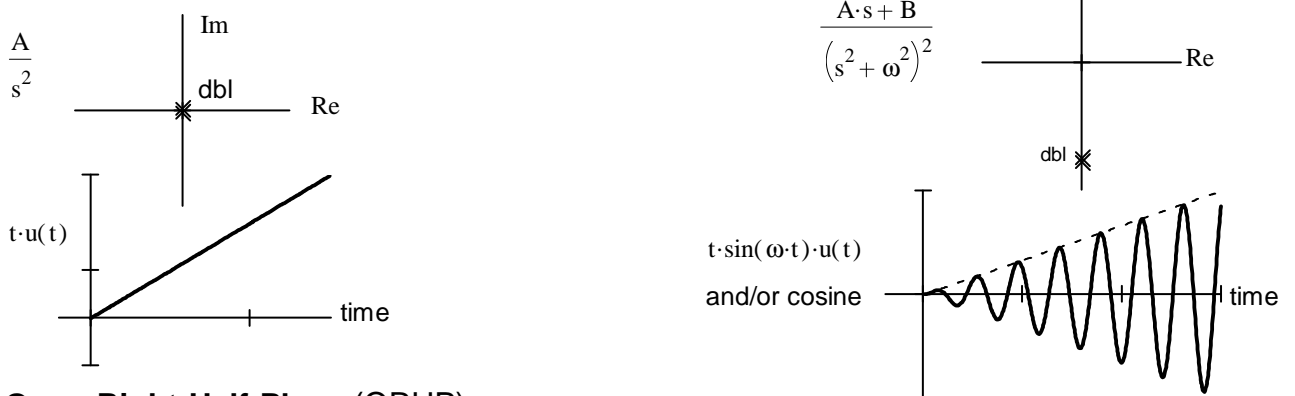

In the Open-Right-Half-Plane (ORHP)

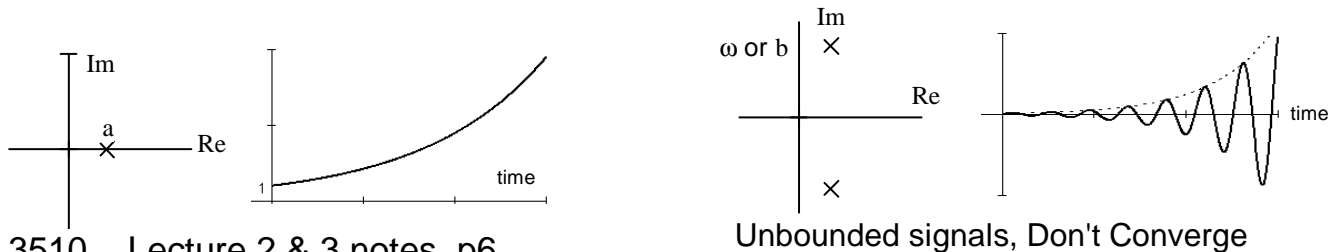

ECE 3510 Laplace Transforms (Unilateral)

<u>f(t)</u>	<u>F(s)</u>	
$f(t) = \frac{1}{2 \cdot \pi \cdot j} \int_{c-j\infty}^{c+j\infty} F(s) \cdot e^{s \cdot t} ds$ <p style="text-align: center; margin-left: 100px;">c is a constant within the region of convergence</p>	$F(s) = \int_0^{\infty} f(t) \cdot e^{-s \cdot t} dt$	
1 $\delta(t)$	1	
2 $u(t)$	$\frac{1}{s}$	
3 $t \cdot u(t)$	$\frac{1}{s^2}$	
4 $t^n \cdot u(t)$	$\frac{n!}{s^{n+1}}$	
5a $e^{a \cdot t} \cdot u(t)$	$\frac{1}{s - a}$	
5b $e^{-\frac{t}{\tau}} \cdot u(t)$	$\frac{1}{s + \frac{1}{\tau}}$	$\tau = -\frac{1}{a} = \text{time constant}$
6 $t \cdot e^{a \cdot t} \cdot u(t)$	$\frac{1}{(s - a)^2}$	
7 $t^n \cdot e^{a \cdot t} \cdot u(t)$	$\frac{n!}{(s - a)^{n+1}}$	
8a $\cos(b \cdot t) \cdot u(t)$	$\frac{s}{s^2 + b^2}$	$b = \omega = \text{radian frequency}$
8b $\sin(b \cdot t) \cdot u(t)$	$\frac{b}{s^2 + b^2}$	
9a $e^{a \cdot t} \cdot \cos(b \cdot t) \cdot u(t)$	$\frac{s - a}{(s - (a + bj)) \cdot (s - (a - bj))} = \frac{s - a}{s^2 - 2 \cdot a \cdot s + (a^2 + b^2)}$ $\frac{s - a}{(s - a)^2 + b^2} = \frac{s - a}{s^2 + 2 \cdot \zeta \cdot \omega_n \cdot s + \omega_n^2}$	
9b $e^{a \cdot t} \cdot \sin(b \cdot t) \cdot u(t)$	$\frac{b}{(s - (a + bj)) \cdot (s - (a - bj))} = \frac{b}{s^2 - 2 \cdot a \cdot s + (a^2 + b^2)}$ $\frac{b}{(s - a)^2 + b^2} = \frac{b}{s^2 + 2 \cdot \zeta \cdot \omega_n \cdot s + \omega_n^2}$	
11a $t \cdot e^{a \cdot t} \cdot \cos(b \cdot t) \cdot u(t)$	$\frac{(s - a)^2 - b^2}{[(s - a)^2 + b^2]^2} = \frac{(s - a)^2 - b^2}{[s^2 - 2 \cdot a \cdot s + (a^2 + b^2)]^2}$	
11b $t \cdot e^{a \cdot t} \cdot \sin(b \cdot t) \cdot u(t)$	$\frac{2 \cdot b \cdot (s - a)}{[(s - a)^2 + b^2]^2} = \frac{2 \cdot b \cdot (s - a)}{[s^2 - 2 \cdot a \cdot s + (a^2 + b^2)]^2}$	

Euler's equations $\cos(\omega t) = \frac{e^{j \cdot \omega t} + e^{-j \cdot \omega t}}{2}$

$\sin(\omega t) = \frac{e^{j \cdot \omega t} - e^{-j \cdot \omega t}}{2 \cdot j}$

ECE 3510 Laplace Properties

<u>Operation</u>	<u>f(t)</u>	<u>F(s)</u>
Addition	$f(t) + g(t)$	$F(s) + G(s)$
Scalar multiplication	$k \cdot f(t)$	$k \cdot F(s)$
Linearity	$k \cdot f(t) + n \cdot g(t)$	$k \cdot F(s) + n \cdot G(s)$
Time differentiation	$\frac{d}{dt} f(t)$	$s \cdot F(s) - f(0^-)$
	$\frac{d^2}{dt^2} f(t)$	$s^2 \cdot F(s) - s \cdot f(0^-) - \frac{d}{dt} f(0^-)$ initial slope
	$\frac{d^3}{dt^3} f(t)$	$s^3 \cdot F(s) - s^2 \cdot f(0^-) - s \cdot \left(\frac{d}{dt} f(0^-) \right) - \frac{d^2}{dt^2} f(0^-)$ initial slope initial curvature
Time integration	$\int_{0^-}^t f(\tau) d\tau$	$\frac{1}{s} \cdot F(s)$
	$\int_{-\infty}^t f(\tau) d\tau$	$\frac{1}{s} \cdot F(s) + \frac{1}{s} \cdot \int_{-\infty}^{0^-} f(t) dt$
Time shift	$f(t - t_0) \cdot u(t - t_0)$	$F(s) \cdot e^{-s \cdot t_0}$ $t_0 \geq 0$
Frequency shift	$f(t) \cdot e^{s_0 t}$	$F(s - s_0)$
Frequency differentiation	$-t \cdot f(t)$	$\frac{d}{ds} F(s)$
Frequency integration	$\frac{f(t)}{t}$	$\int_s^{\infty} F(s') ds'$
Scaling	$f(a \cdot t)$ $a \geq 0$	$\frac{1}{a} \cdot F\left(\frac{s}{a}\right)$
Time convolution	$f(t) * g(t)$	$F(s) \cdot G(s)$
Frequency convolution	$f(t) \cdot g(t)$	$\frac{1}{2 \cdot \pi \cdot j} \cdot F(s) * G(s)$
Initial value	$f(0^+)$	$\lim_{s \rightarrow \infty} s \cdot F(s)$ $n > m$ # of poles > # of zeroes
Final value	$f(\infty)$	$\lim_{s \rightarrow 0} s \cdot F(s)$ (all poles of sF(s) in LHP)

Homework should be handed in through Canvas as a .pdf file. Homework is due by 11:59 p.m. on the due date.

Identify Feedback Systems Listen carefully to lecture 1 and read Chapter 1 of the Bodson text.

1. Look for feedback systems around your house, school and where you work. Think about the subsystems within your computer, your car, and your entertainment equipment. Think back to previous classes and try to identify feedback systems that were used to stabilize circuits. (You don't need to write anything down here, you'll do that in the next problem, possibly using 2 you've thought of here.)
2. Identify at least 2 different feedback systems found around your house, school and where you work. For each of these systems:
 - a) Draw a system diagram, identifying each of the parts (controller, plant, feedback signal and/or sensor, and possibly others). If you're not sure how the system works or how individual parts of the system work, make educated guesses– think how you would make such a system work. You will almost certainly have to simplify the system, considering only one input, one output, and one type of feedback. Assume all else which may affect the output is held constant.
 - b) Identify the input on the drawing (may be zero or some reference value).
 - c) Identify the output (response).
 - d) Identify the feedback signal (often same as the output).
 - e) What would happen if this system did not respond accurately to the control and the output looked like that shown below (or like Figure 1.2 b in the Bodson text)?
 - f) What would happen if this system responded to the control with overshoot or ringing like that shown below (or like Figure 1.2 c in the text)?
3. Repeat problem 2a) - d) for a feedback system outside of your normal environment.
4. Repeat problem 2a) - d) for a natural feedback system, that is, not made by man.

Examples

Ex.1. Automobile cruise control a) drawing below

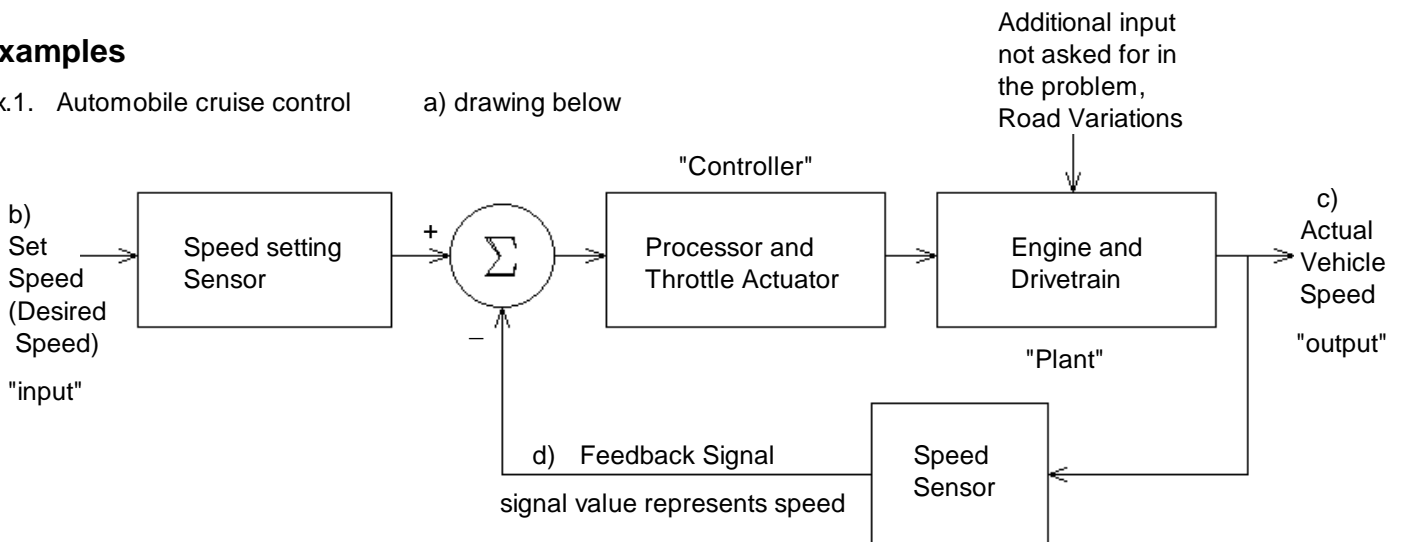

- e) The vehicle speed might not match the set speed, or might respond very slowly.
- f) The vehicle speed could vary wildly creating a very unsafe situation.

ECE 3510 homework # 1 p2

Ex.2 Widget price feedback system.

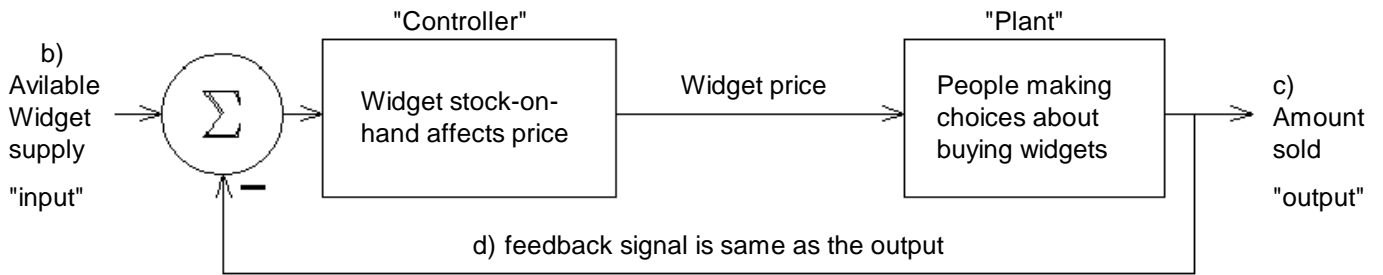

e) What would happen if this system did not respond accurately to the control and the output looked like that shown below (or like Figure 1.2 b in the Bodson text)?

Output of a feedback or control system

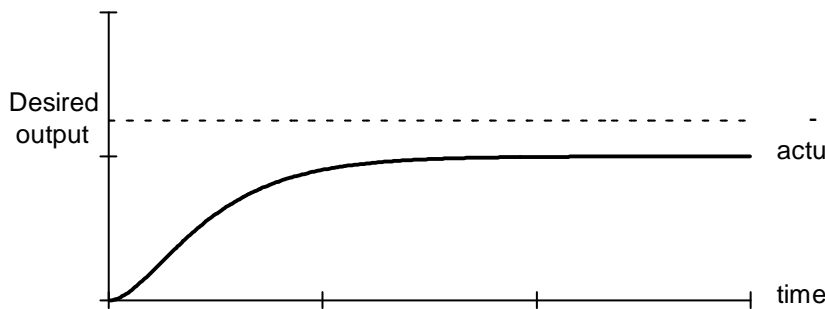

In our widget example
 = demand matches supply
 = actual demand
 Overstock would build up in some sort of storage.

f) What would happen if this system responded to the control with overshoot or ringing like that shown below (or like Figure 1.2 c in the text)?

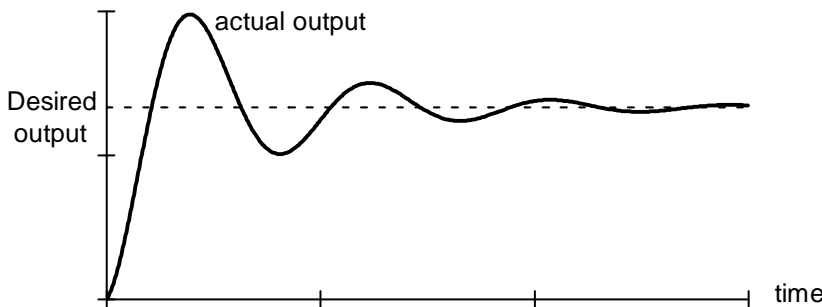

Response to a change in supply
 Widget demand (also price and stock) fluctuate wildly because price is too sensitive to stock variations. Demand eventually settles to match supply.

Note: This same system could also be drawn this way, if you consider the widget price as the "output"

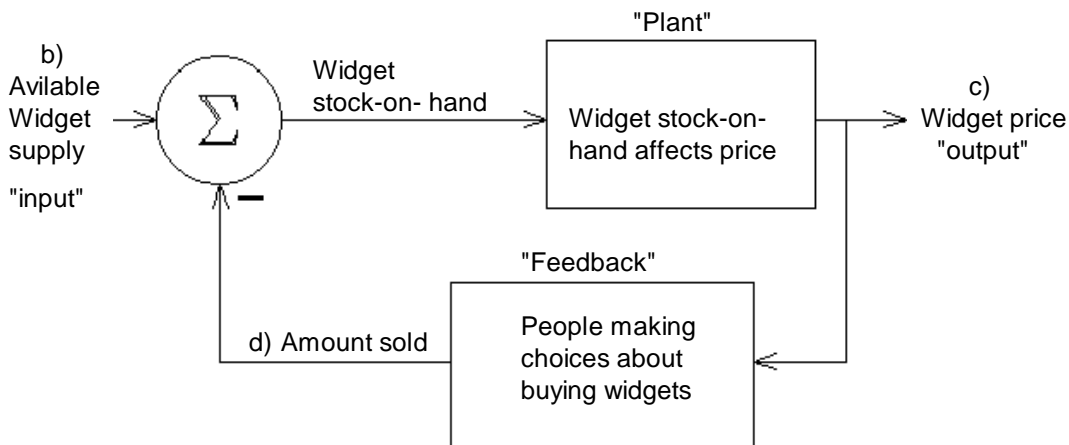

Homework should be turned in to Canvas as a .pdf file by 11:59pm on the due date.

Good LaPlace Transform tables: Nielson p.595 (7th ed.,p.547), Lathi p.372, Bodson p.17, Nise, p.40, Class handouts

Good LaPlace Property tables: Nielson p.601 (7th ed.,p.553), Lathi p.389, Bodson p.20, Nise p.41, Class handouts

For problems 1 & 2:

Don't just write down what the table shows.

You must show some work of your own.

You may use simpler table entries together with properties of the Laplace transform.

1. Find the Laplace transform of the following functions: See instructions above

- a) $u(t)$
- b) $\sin(\omega \cdot t) \cdot u(t)$
- c) $t \cdot u(t)$

2. Find the Laplace transform of the following functions: See instructions above

- a) $e^{-at} \cdot \sin(\omega \cdot t) \cdot u(t)$
- b) $e^{-at} \cdot \cos(\omega \cdot t) \cdot u(t)$

3. Look at the figures on the **next page**. Each set of real (horizontal) and imaginary (vertical) axes show the poles of a signal transform on the s-plane.

a) Find the best matching time-domain signal or answer in "Answers for problem 3" section (following page).

Answers may be used more than once or not at all, but make a little check mark next to each on that you do use.

Don't overlook answers A and B, which are written only (no figure).

The axes all have the same scaling. All time scales on the ANSWERS page are the same.

Your answers should make sense relative to one another.

dbl = double pole at that location

Answers

1. a) $\frac{1}{s}$ b) $\frac{\omega}{s^2 + \omega^2}$ c) $\frac{1}{s^2}$ 2. a) $\frac{\omega}{(s+a)^2 + \omega^2}$ b) $\frac{(s+a)}{(s+a)^2 + \omega^2}$

3. a) 1) E 2) F 3) K 4) C 5) H or L 6) L 7) M 8) N 9) A 10) R 11) S 12) P

b) 7 10 11 c) 7 8 10 11 12

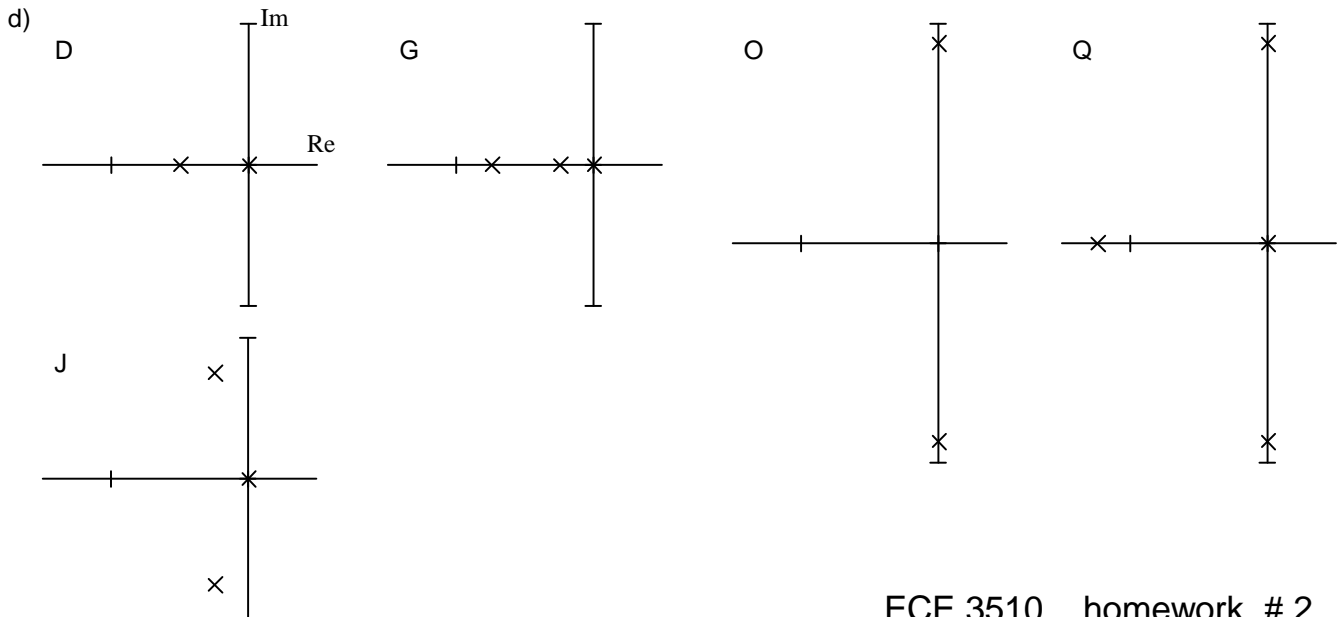

3. See instructions on previous page

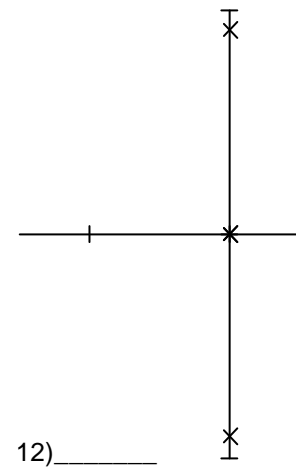
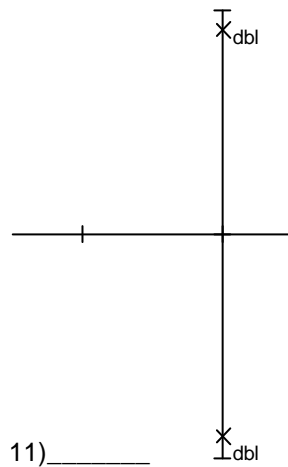
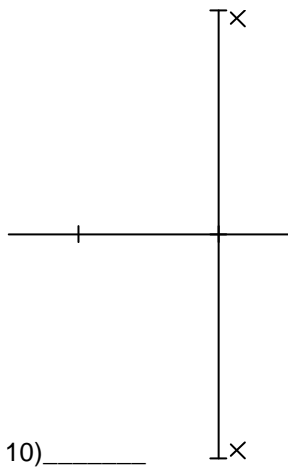
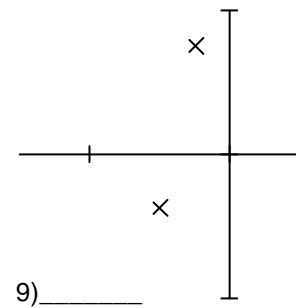
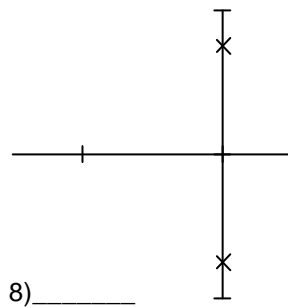
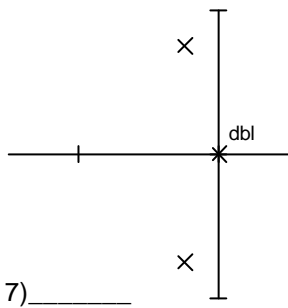
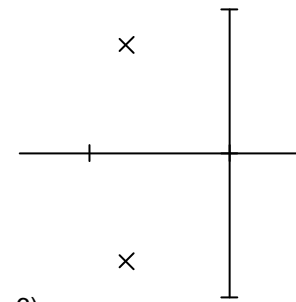
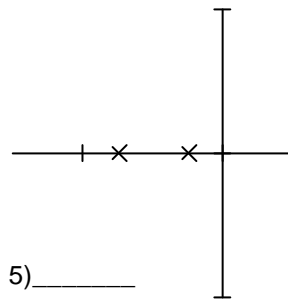
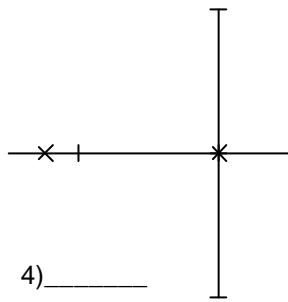
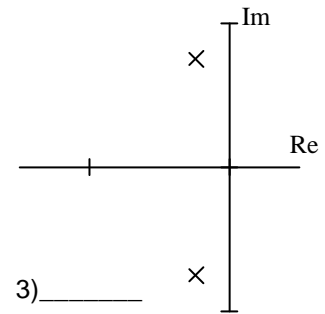
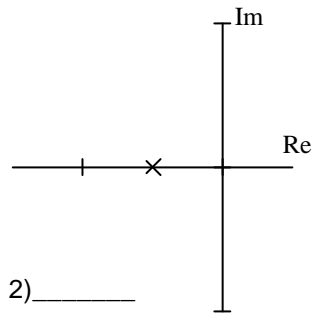
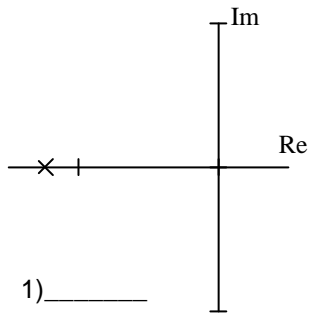

b) List those numbers above that represent signals that are UNBOUNDED.

c) List those numbers above that represent signals that DO NOT converge.

d) Several of the answers on the next page were not used.

For each of the answers that were **not** used, draw the poles of that time-domain signal on a set of real and imaginary axes (an s-plane). Scale your axes just like the ones above.

e) Keep the "Answers for problem 3" page. I may refer to it again in future homework problems.

Answers for problem 3 All horizontal axes are time.

- A No real time-domain answer could match these pole(s)
- B None of these time-domain answers match these poles

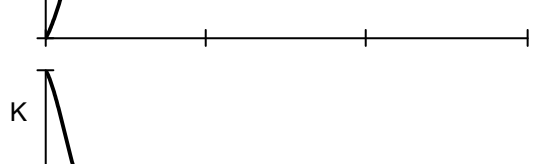
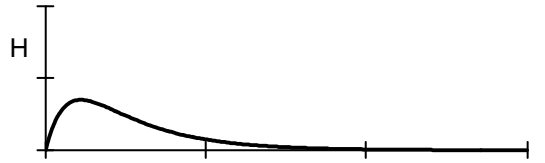
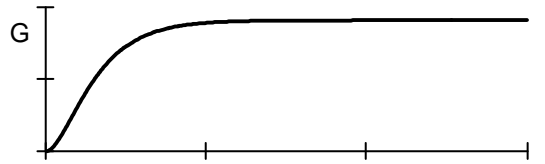
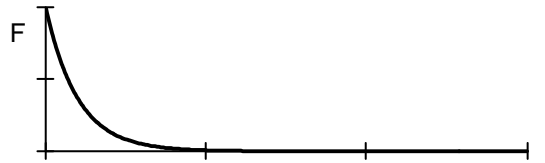
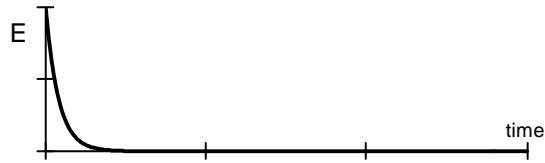
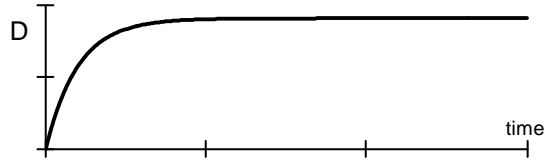

KEEP THIS PAGE FOR FUTURE USE

