

### A. Introduction

Electronic displays are found in devices we use every day: watches, personal organizers, appliances, calculators, and computers, to name a few. For displays with many elements, one efficient design approach is to use row and column addressing. In this scheme, one terminal of all pixels in one *column* are connected to one conductor, and the other terminal of all pixels in one *row* are connected to another conductor. Fig. 1 illustrates this scheme for a 7-segment LED display where the segments play the role of pixels.

To light one segment of one digit in the LED display, one row line becomes active and one column line becomes active. In practice we turn on entire digits in succession: we activate all the segments for a digit, we activate the column line for that digit, then we move on to the next digit, repeating the process *ad infinitum*. Because only one set of segment drivers is used for the all the digits, this is referred to as a multiplexed display.

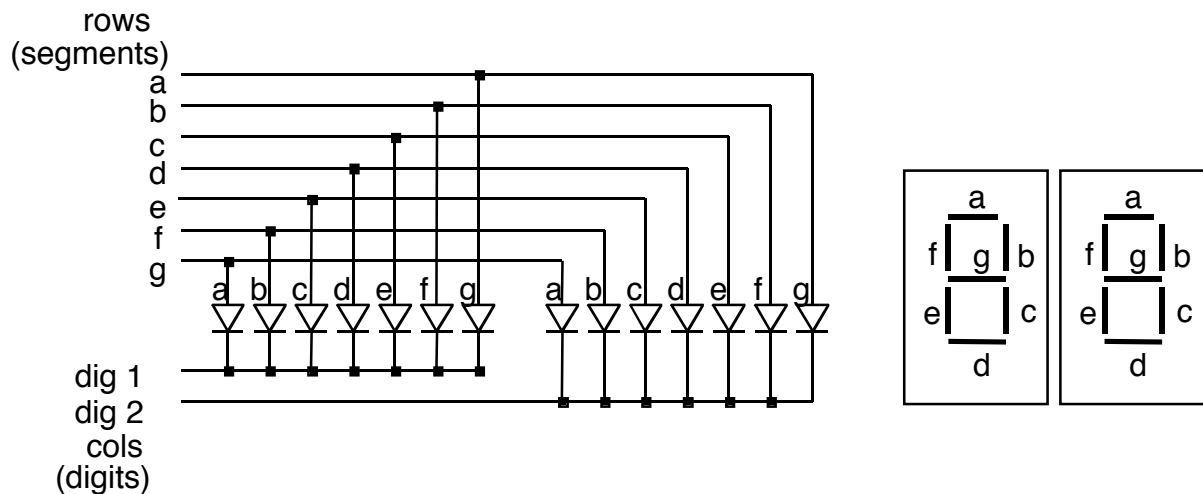

Fig. 1. Multiplexed 2-digit, 7-segment LED display circuit.

A potential problem with row-and-column addressing is that electrical current may follow indirect paths from the row conductor to the column conductor. If the LEDs behaved like resistors, we might observe spurious segments lighting up. This does not happen in practice because the LEDs, unlike resistors, are nonlinear. They, like other diodes, pass current in only one direction. On all indirect paths, current would have to pass through at least one LED in the wrong direction. Thus, nonlinear devices have an advantage in large display applications.

## B. Your Design Project

Your project is to design an LED driver circuit consisting of a resistor in series with an LED. When the resistor and LED are connected across a power supply, the LED should light up.

First you will characterize your diode by measuring the current flowing through it as a function of the voltage across it. Using MATLAB™, you will apply the method of least squares to estimate parameters for a simplified model of the LED. Then, using MATLAB™, you will apply a nonlinear optimization algorithm to estimate parameters for a more accurate model of the LED. Finally, you will estimate the LED turn-on voltage and use this value to choose a resistor value for the LED circuit.

## C. Model the LED (linear regression)

During the first laboratory period, you must measure the  $i$ - $v$  characteristics of your LED. Shockley's law describes the relationship between current and voltage for diodes:

$$i = I_s \left( e^{v/V_T} - 1 \right) \quad (1)$$

where

$i$  ≡ current through diode in Amps

$v$  ≡ voltage across diode in Volts

$I_s$  ≡ reverse saturation current in Amps

$V_T$  ≡ thermal voltage =  $kT/q$  in Volts  $\approx 26$  mV at room temperature

$k$  ≡ Boltzmann constant =  $1.38 \cdot 10^{-23}$  J°K

$T$  ≡ temperature °K (293 °K = 68°F, 300°K = 80.6°F)

$q$  ≡ electronic charge =  $1.602 \cdot 10^{-19}$  C

Because Shockley's law is exponential, the current in the LED increases extremely rapidly beyond a voltage referred to as the turn-on voltage. For a small red LED, this is around 1.4 V. To avoid burning out the LED, we control the current with a resistor:

1. Use a 12 Volt power supply as your voltage source.
2. Use a 5 kΩ potentiometer in series with the LED.
3. Connect a volt-meter across the LED and a current meter in series with it.
4. Using various potentiometer settings, measure at least four current versus voltage data points for your LED.
5. Plot  $\ln(i)$  versus  $v$ , which should be close to a straight line. Plot the data by hand before you dismantle your equipment to be sure that your results are correct.
6. Use MATLAB to do a linear regression to fit the best straight line to your data and obtain  $I_s$  and  $T$  for your LED. (Note: we ignore the  $-1$  in equation (1).)

**D. Model the LED (nonlinear "fmins" optimization)**

1. Write a MATLAB function that will calculate the total mean squared error for all your measured current values,  $i$ , and the Shockley equation's predicted current values,  $\hat{i}$ , for a given choice of  $T$  and  $I_s$ . Note: the MATLAB function *fmins* will adjust  $T$  and  $I_s$  to minimize the error.
2. Write a MATLAB™ script file to find the optimal  $T$  and  $I_s$  for Shockley's law:
  - a. Create global arrays containing the measured data.
  - b. Call the MATLAB™ function *fmins* to find the optimal  $T$  and  $I_s$ .
  - c. Plot the measured data and the Shockley's law values on the same set of axes.

**E. Design the Circuit**

1. Using the results from part D, estimate the turn-on voltage for the LED.
2. Use your value of turn-on voltage to calculate a resistance that will result in a current of 8 mA through the LED.

**F. Test the Circuit**

1. Construct the circuit that you designed and verify that it lights the LED.
2. Measure the actual voltage across the LED and the current flowing through it.

**G. Write a Formal Report**

Write a formal report describing your work on this project. See instructions in "Course Procedures" about how to write the report. Include at least the following in your report:

1. A short introduction. You may attach this handout to the report in the appendix and refer to it so that you don't have to copy the information in it.
2. A careful description of the work that you did in parts C through F above.
  - a. Give clear derivations of the mathematical expressions. Include consistency checks.
  - b. Explain how you chose the value of the components and include a table listing the component values.
  - c. Explain all measurements carefully and include data appropriately in clearly labeled tables and graphs in the body of the report.
  - d. Include a listing of your computer program in an appendix, and explain how the program works.
  - e. Give a clear comparison of measured and calculated values. Include a plot of calculated and measured LED current on the same set of axes. Explain why calculated and measured values are not the same.

3. Conclusions, including:
  - a. A discussion of the validity of the models used for the LED.
  - b. A discussion of the success of your design procedure. Comment on the limitations and advantages of using the turn-on voltage instead of the complete Shockley's-law model when selecting a resistor value.

**H. Your Grade**

Your report will be graded according to the following:

<u>Category</u>	<u>Points</u>
Communications	30
C. Matlab™ Program (lin regression)	18
D. Matlab™ Program (fmins)	23
E. Turn-on V and resistor values	12
F. Circuit measurements	12
G. Conclusions	<u>5</u>
Total	100