

2. (30 points)

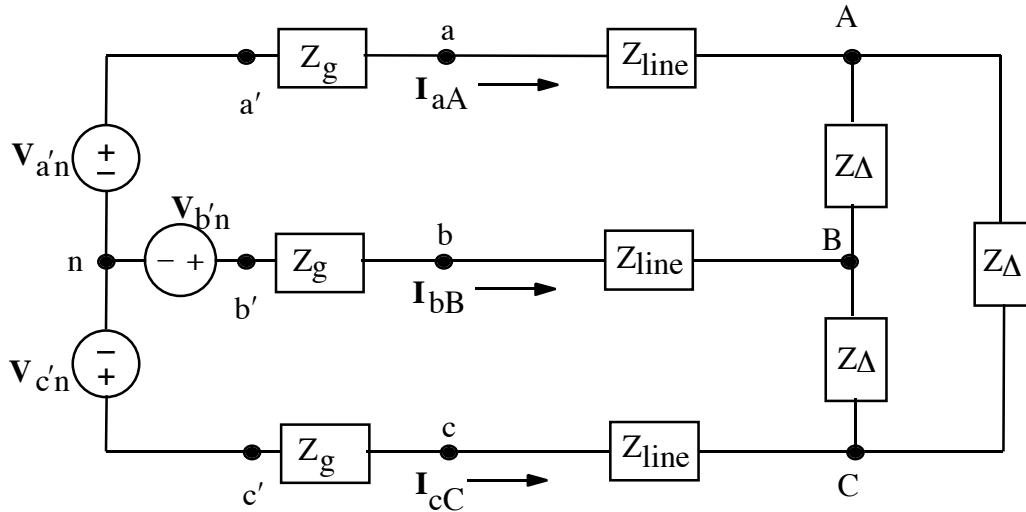

Balanced three-phase, positive-sequence system
 $\mathbf{I}_{aA} = 15 \angle 0^\circ \text{ A}$ $Z_g = (0.2 + j0.2)\Omega$
 $\mathbf{V}_{aA} = 22.5 \angle 53.13^\circ \text{ V}$ $Z_\Delta = (30 + j24)\Omega$

- Draw a single-phase equivalent circuit.
- Calculate \mathbf{I}_{AB} .

ans: a)

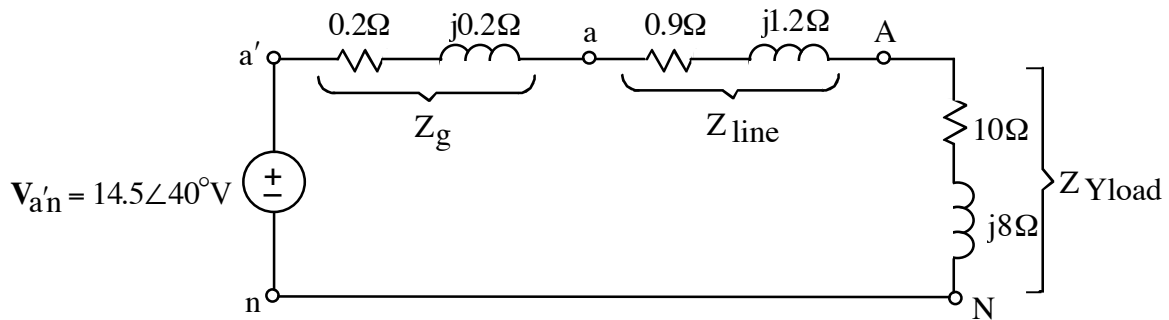

b) $\mathbf{I}_{AB} = 8.7 \angle 30^\circ \text{ A}$

sol'n: (a) First, we use Ohm's law to find z_{line}

$$Z_{line} = \frac{\mathbf{V}_{aA}}{\mathbf{I}_{aA}} = \frac{22.5 \angle 53.13^\circ \text{ V}}{15 \angle 0^\circ \text{ A}} = 1.5 \angle 53.13^\circ \Omega$$

We write z_{line} in rectangular form so we can add it to other impedances later on. Note that z_{line} remains unchanged by any transformations of the source or load from Y to Δ or Δ to Y.

$$Z_{line} = 0.9 + j1.2\Omega$$

To find the single-phase equivalent, we convert the source end and the load end to Y configurations. Since the source end is already a Y configuration, it remains unchanged.

$$Z_g = 0.2 + j0.2\Omega$$

Transforming the load from Δ to Y results in the load z being divided by 3:

$$Z_{Yload} = \frac{Z_{\Delta}}{3} = \frac{30 + j24\Omega}{3} = 10 + j8\Omega$$

We now use Ohm's law to calculate the source voltage. Note that I_{aA} is the same for z_{Δ} as it is for z_{Yload} .

$$V_{a'n} = I_{aA} (Z_g + Z_{line} + Z_{Yload})$$

$$V_{a'n} = 15\angle 0^\circ \text{ A} (0.2 + j0.2 + 0.9 + j1.2 + 10 + j8)\Omega$$

$$V_{a'n} = 15\angle 0^\circ (11.1 + j9.4)\text{V} = 14.5\angle 40^\circ \text{ V}$$

sol'n: (b) We first observe that applying Ohm's law translates the problem into one of finding V_{AB} .

$$I_{AB} = \frac{V_{AB}}{Z_{\Delta}}$$

A phasor diagram reveals the relative magnitude and phase angle for V_{AB} versus V_{AN} . When we draw such a diagram, we always start with the shorter side, V_{AN} , and we place it along the real axis. Because this is the most practical way to draw the diagram, we proceed in this fashion even if we are trying to derive V_{AN} from V_{AB} . What the diagram gives us is the *relative* magnitude and phase angle of V_{AB} compared to V_{AN} . We can then derive a formula that takes us from V_{AN} to V_{AB} or vice versa.

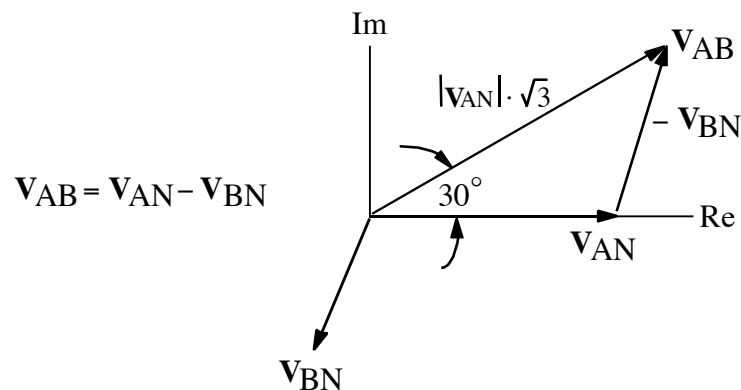

From the diagram, we have

$$\mathbf{V}_{AB} = \mathbf{V}_{AN} \sqrt{3} \angle 30^\circ \text{ V.}$$

We find \mathbf{V}_{AN} from the single-phase model.

$$\mathbf{V}_{AN} = \mathbf{I}_{aA} \cdot Z_{Yload} = \mathbf{I}_{aA} \cdot \frac{Z_\Delta}{3}$$

Substituting into the equation for \mathbf{I}_{AB} , we have

$$\mathbf{I}_{AB} = \frac{\mathbf{I}_{aA} \cdot (Z_\Delta / 3) \sqrt{3} \angle 30^\circ}{Z_\Delta} = \frac{\mathbf{I}_{aA} \angle 30^\circ}{\sqrt{3}}.$$

Note: This formula is tabulated in some books, but deriving it ensures that we have the correct sign for the relative phase shift. Whether we shift by $+30^\circ$ or -30° depends on whether we have a positive-phase or a negative-phase system.

$$\mathbf{I}_{AB} = 15 \angle 0^\circ \cdot \frac{1}{\sqrt{3}} \angle 30^\circ = \frac{15}{\sqrt{3}} \angle 30^\circ = 8.7 \angle 30^\circ \text{ A}$$