

Ex:

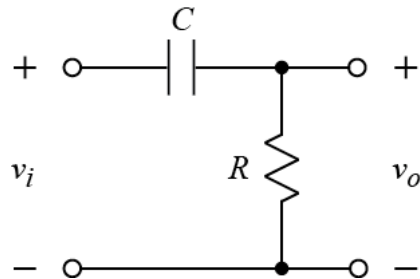

$$R = 1 \text{ k}\Omega \quad C = 40 \text{ pF}$$

- Determine the transfer function V_o/V_i .
- Plot $|V_o/V_i|$ versus ω .
- Find the cutoff frequency, ω_c .

SOL'N: a) We transform the circuit to the frequency domain.

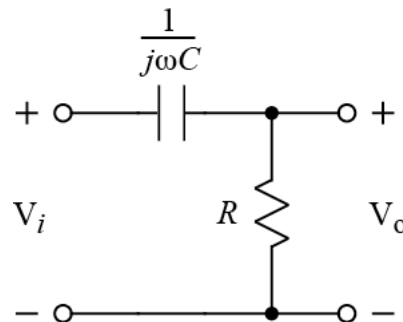

The voltage-divider formula gives the transfer function, starting with the formula for V_o :

$$V_o = V_i \frac{R}{R + \frac{1}{j\omega C}}$$

Dividing by V_i gives the transfer function:

$$H(j\omega) = \frac{V_o}{V_i} = \frac{R}{R + \frac{1}{j\omega C}}$$

A better form is obtained by dividing top and bottom by $j\omega R$:

$$H(j\omega) = \frac{1}{1 + \frac{1}{j\omega RC}} = \frac{1}{1 - j \frac{1}{\omega RC}} = \frac{1}{1 - j \frac{1}{\omega 1\text{k} \cdot 40\text{p}}} = \frac{1}{1 - j \frac{25\text{M}}{\omega}}$$

b) The plot is generated with the following Matlab® code.

```
% ECE2260F10_HW3p2soln.m
%
% Plot of transfer function of RC high-pass filter.

R = 1e3;
C = 40e-12;

omega = 1e6:1e6:100e6;
H = 1 ./ (1 - j*1./(omega*R*C));

plot(omega,abs(H))
xlabel('omega')
ylabel('|H|')
```

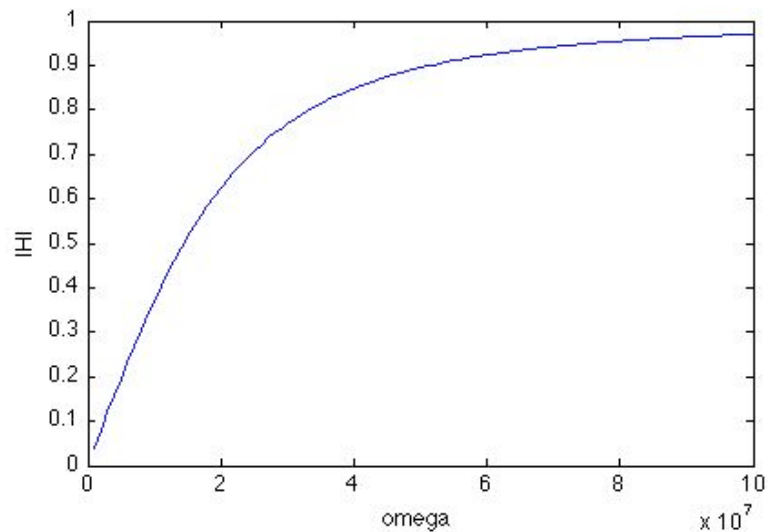

c) We find the cutoff frequency by setting the magnitude of the transfer function equal to $1/\sqrt{2}$ times the max value of $|H|$.

$$|H(j\omega_c)| = \frac{1}{\sqrt{2}} \max_{\omega} |H(j\omega)| = \frac{1}{\sqrt{2}}$$

We observe that $\sqrt{2} = |1 \pm j|$ meaning we can solve for ω_c by setting $25M/\omega$ equal to one:

$$\frac{25M}{\omega_c} = 1$$

or

$$\omega_c = 25M\text{r/s}$$