

1.

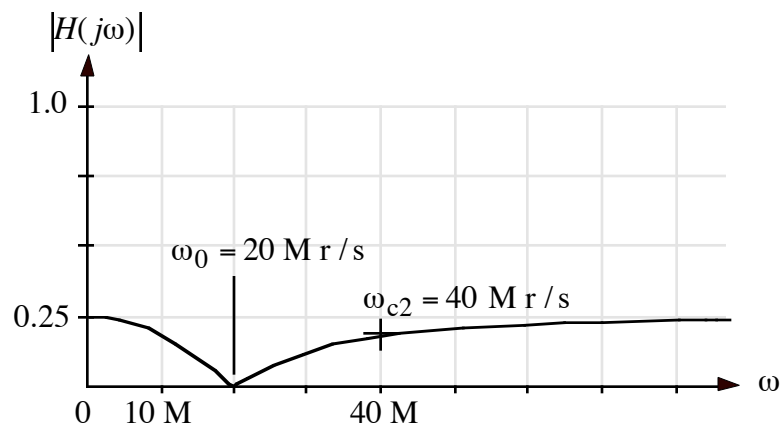
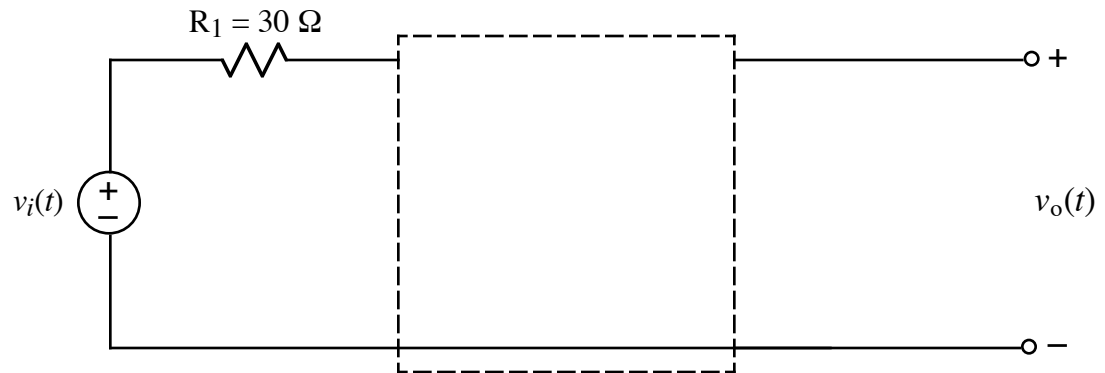

Given the resistor connected as shown and using not more than one each R, L, and C in the dashed-line box, design a circuit to go in the dashed-line box that will produce the **band-reject** $|H(j\omega)|$ vs. ω shown above. That is:

$$\min_{\omega} |H(j\omega)| = 0 \text{ and occurs at } \omega_0 = 20 \text{ M r/s}$$

$$\text{upper cutoff frequency } \omega_{c2} = 40 \text{ M r/s}$$

$$|H(j\omega)| = \frac{1}{4} \text{ at } \omega = 0 \quad \text{and} \quad \lim_{\omega \rightarrow \infty} |H(j\omega)| = \frac{1}{4}$$

2.

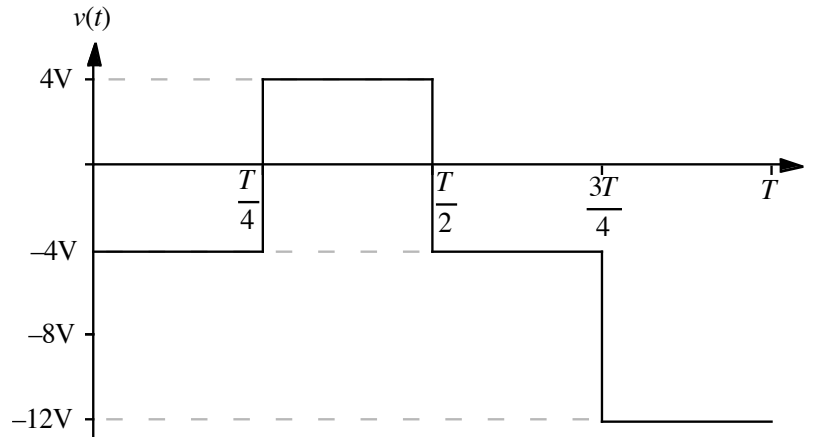

One period, T , of a function $v(t)$ is shown above. The formula for $v(t)$ is

$$v(t) = \begin{cases} -4 \text{ V} & 0 < t < T/4 \\ 4 \text{ V} & T/4 < t < T/2 \\ -4 \text{ V} & T/2 < t < 3T/4 \\ -12 \text{ V} & 3T/4 < t < T \end{cases}$$

Find the numerical value of the following coefficients of the Fourier series for $v(t)$: (Hint: remove the DC offset after finding its value.)

a) a_v

b) a_1

3.

Find the value of b_1 and b_2 for the Fourier series in problem 2.

4.

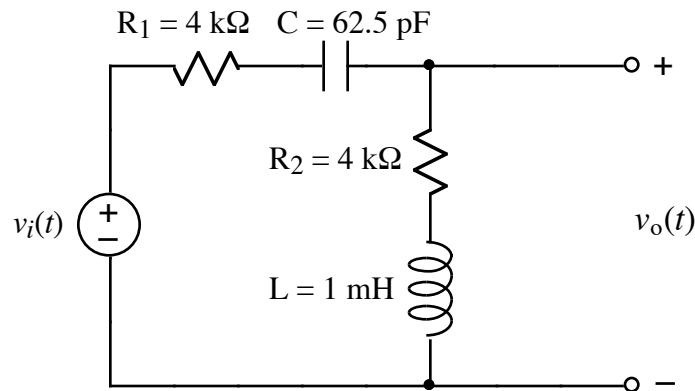

For the above circuit, determine the transfer function $H(j\omega) = V_o/V_i$.

5.

Assume the circuit in problem 4, has the following input signal:

$$v_i(t) = 32 + \sum_{k=1}^{\infty} \frac{16}{k\pi} \left[\sin\left(\frac{k\pi}{4}\right) \cos(k\omega_0 t) + \cos\left(\frac{k\pi}{4}\right) \sin(k\omega_0 t) \right] \text{ V}$$

Note: $\omega_0 = 1 \text{ M rad/s}$ for the Fourier series.

Write the time-domain expression of the fourth harmonic (i.e., $k = 4$) of $v_o(t)$.