

2.

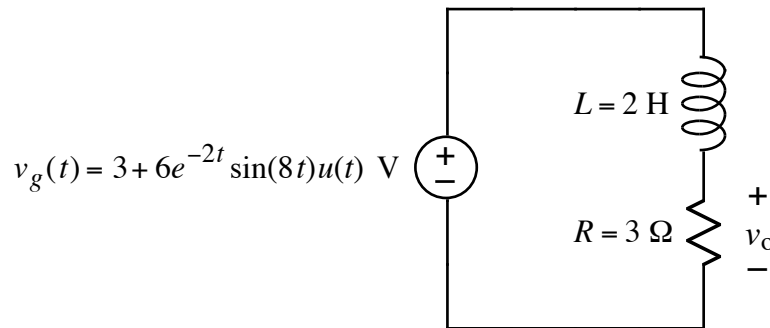

Note: The 3 V in the $v_g(t)$ source is always on.

- Write the Laplace transform, $V_g(s)$, of $v_g(t)$.
- Draw the s -domain equivalent circuit, including source $V_g(s)$, components, initial conditions for L , and terminals for $V_o(s)$.
- Write an expression for $V_o(s)$.
- Apply the initial value theorem to find $\lim_{t \rightarrow 0^+} v_o(t)$.

SOL'N: a) We treat the 3V as $3u(t)$:

$$V_g(s) = \frac{3}{s} + 6 \cdot \frac{8}{(s+2)^2 + 8^2} = \frac{3}{s} + \frac{48}{(s+2)^2 + 8^2}$$

- We find initial conditions by considering the circuit at $t = 0^-$. The source at that time is a constant 3V, and the L acts like a wire.

$$i_L(t = 0^-) = \frac{3V}{3\Omega} = 1A$$

For convenience, we use a series voltage source of value $Li_L(0^-)$ for the initial conditions on the L :

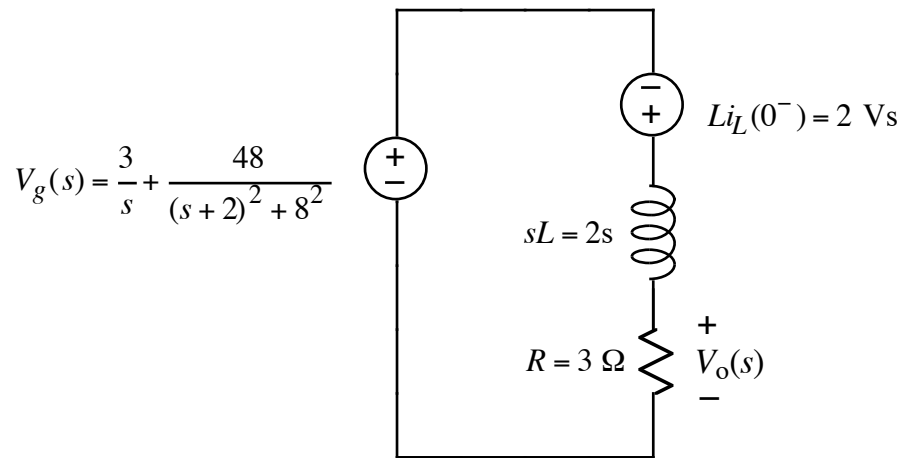

c) We have a voltage-divider driven by the sum of the voltage sources:

$$V_o(s) = \left[V_g(s) + Li_L(0^-) \right] \frac{R}{sL + R} = \left[\frac{3}{s} + \frac{48}{(s+2)^2 + 8^2} + 2 \right] \frac{3}{2s+3}$$

d) We use the initial value theorem:

$$\lim_{t \rightarrow 0^+} v_o(t) = \lim_{s \rightarrow \infty} sV_o(s) = \lim_{s \rightarrow \infty} s \left[\frac{3}{s} + \frac{48}{(s+2)^2 + 8^2} + 2 \right] \frac{3}{2s+3}$$

We multiply through by s :

$$\lim_{s \rightarrow \infty} sV_o(s) = \lim_{s \rightarrow \infty} \left[3 + \frac{48s}{(s+2)^2 + 8^2} + 2s \right] \frac{3}{2s+3}$$

We need a polynomial over a polynomial so we can identify the highest power of s on the top and bottom:

$$\lim_{s \rightarrow \infty} sV_o(s) = \lim_{s \rightarrow \infty} \left[\frac{[3 + 2s][(s+2)^2 + 8^2] + 48s}{(s+2)^2 + 8^2} \right] \frac{3}{2s+3}$$

The result is as follows:

$$\lim_{s \rightarrow \infty} sV_o(s) = \frac{2s^3}{s^2} \cdot \frac{3}{2s} = 3$$

The above is the same as what we seek:

$$\lim_{t \rightarrow 0^+} v_o(t) = 3 \text{ V}$$