

# Laboratory Project 3: Spirogravitator

K. Durney and N. E. Cotter  
Electrical and Computer Engineering Department  
University of Utah  
Salt Lake City, UT 84112

**Abstract-You will build a secret weapon (secret because no one has figured out how to use it as a weapon) based on an RLC circuit and an op-amp. A more practical use for the circuit would be to power down a two-phase motor. Using Laplace transform techniques, you will design the circuit so it produces decaying sinusoids  $90^\circ$  out of phase.**

## I. PREPARATION

For Lab 3, which will last about three weeks, you will need the parts listed in Table I. You may purchase these parts from the stockroom next to the lab or purchase them elsewhere.

TABLE I  
PARTS LIST FOR LAB 3

Item	Qty	Description
1	1	LF 353 op-amp
2	1	100 mH inductor
3	2	Capacitor (values determined by calculations)
4	3	Resistor (values determined by calculations)

## II. LEARNING OBJECTIVES

- 1) Learn how to solve  $RLC$  circuits using Laplace transforms.
- 2) Learn how to extract function parameters from a waveform.

## III. INTRODUCTION

This is Captain Quirk of the Starship Surprise. We are surrounded by Klingulon ships in quadrant 19, sector 80 (the 2nd floor of MEB). The Klingulons are closing and preparing to attack. We (TA's) are outnumbered 35 to 1 and have no operational photon torpedoes or phasor banks (or dry markers). The situation is critical. We have no choice but to use the Federation's new weapon, the spirogravitator, untried as it may be. Mr. Shock (so-called for his lab technique) informs me the new weapon may only be used in spiral form; at this time it is impossible to use it as a normal straight-line weapon due to untold possibilities and problems that may exist. Mr. Shock has already plotted the locations of Klingulon vessels, but it is impossible for him to plot the spiral path of the weapon. All Vulcan-o's like Mr. Shock have a mind block against spirals and erupt if a spiral is visible in the immediate surroundings. However, it is imperative that the spiral be plotted on the scope before the spirogravitator is used, to be sure that none of the nearby planets (or students) are in the weapon's path. We are now screening the crew members (students) to find someone with the spiral-plotting ability. Each candidate will be required to solve a Laplace transform problem, build a spirogravitator circuit, and plot the output on an oscilloscope. Space cadets are preparing for this exercise now.

#### IV. CIRCUIT OVERVIEW

The circuit diagram of the spirogravitator is shown in Fig. 1.  $v_i(t)$  is a square wave that excites a damped oscillation in the series components to the left of the op-amp. The design problem is to select circuit components so that voltages  $v_0$  and  $v_1$  will have equal amplitudes, and will be under-damped with the same frequency of oscillation and the same damping rate, but  $90^\circ$  out of phase, (decaying sine and cosine waveforms, for example). The voltage  $v_0$  is connected to the horizontal input of an oscilloscope and  $v_1$  is connected to the vertical input of the same oscilloscope. This is called x-y mode for the oscilloscope. That is,  $v_0$  controls the left and right movement of a dot on the oscilloscope screen, and  $v_1$  controls the up and down movement of a dot on the oscilloscope screen. (This is similar to the way an Etch-a-Sketch® toy works. The user draws pictures on a screen using two knobs: one knob moves a dot on the screen left and right, and the other knob moves the dot on the screen up and down.) With  $v_0$  and  $v_1$  acting as the horizontal and vertical controls, the resulting pattern on the oscilloscope will be a spiral. When the circuit's input square wave goes low, it excites a second spiral that is an upside-down copy of the first spiral. Each spiral starts where the other ends, and this creates the desired double spiral.

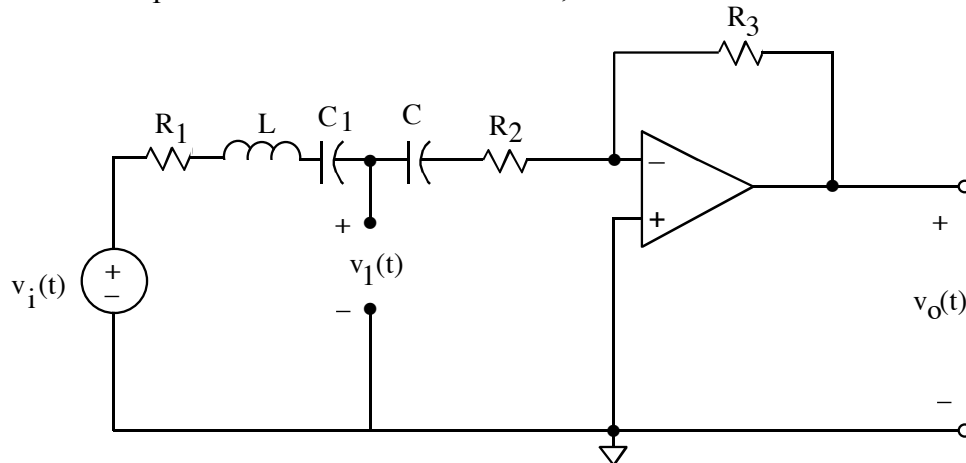

Figure 1. Diagram of the spirogravitator circuit.  $v_i$  is a rectangular wave with zero dc level.

#### V. CIRCUIT OPERATION

Referring to Fig. 1, the heart of the spirogravitator is the series RLC formed by the components to the left of the op-amp. The op-amp itself merely acts as a device for measuring the current in the RLC and turning it into voltage  $v_0$ . The op-amp has negative feedback and operates in linear mode. Consequently, the voltage at  $-$  input equals the voltage at the  $+$  input, which is at reference, or  $0V$ . Thus, the op-amp has a virtual reference at its  $-$  input, meaning that the behavior of the circuit to the left of the op-amp may be analyzed by removing the op-amp and treating the  $-$  input as being connected to reference. The current flowing in the series RLC components may then be computed. Since no current flows into the op-amp, this current actually flows through  $R_3$ , and creates a voltage drop that equals  $v_0(t)$ .

Since the  $-$  input of the op-amp is a virtual reference, voltage  $v_1(t)$  is equal to the voltage across  $C_2$  and  $R_2$ . By splitting the capacitance in two, we may select circuit components so that  $v_0$  and  $v_1$  will have equal amplitudes, will be under-damped with the same frequency of oscillation and the same damping rate, and will be  $90^\circ$  out of phase. With these conditions, the resulting pattern on the oscilloscope will be double spirals that are circular.

## VI. MODEL OF INDUCTOR

For the inductance in the circuit of Fig. 1, use a 100 mH inductor you have purchased. Measure both the inductance and dc resistance of the inductor you use. Do this during the first lab period, as you will need these values for the calculations that you will be making. If you make  $R_1$  and  $R_2$  large compared to  $R_0$ , the resistance of the inductor, you may be able to neglect  $R_0$ . Otherwise, you should include  $R_0$  in  $R_1$ . You will probably find that the shunt capacitance of the inductor and the shunt capacitance of the inputs to the oscilloscope are both negligible here, but that is not always the case.

## VII. ANALYSIS AND DESIGN OF CIRCUIT

### A. Equations

Transform the circuit of Fig. 1 to the  $s$  domain and write expressions for  $V_0(s)$  and  $V_1(s)$ , for a half-period interval when  $v_i(t)$  is positive. (The answers for a half-period when  $v_i(t)$  is negative are the negatives of  $V_1(s)$  and  $V_0(s)$  for a half-period interval when  $v_i(t)$  is positive.) Include initial conditions for the capacitance and inductance. For the derivation of  $V_0(s)$ , assume  $C_1$  and  $C_2$  may be different values, and determine how the initial condition voltages are distributed between them. Note that both capacitors see the same current and store the same amount of charge at all times. For the derivation of  $V_1(s)$ , (and for the construction of the actual circuit), assume  $C_1$  and  $C_2$  are equal.

Make consistency checks to ensure that your expressions are accurate. Take the inverse transforms of  $V_1(s)$  and  $V_0(s)$ . One of them will be of the form

$$a e^{-\alpha t} \sin(\beta t) \quad (1)$$

and the other will be of the form

$$b e^{-\alpha t} \sin(\beta t + \psi) + c \quad (2)$$

where we desire  $\psi = \pm 90^\circ$  so  $\sin(\beta t + \psi)$  becomes  $\pm \cos(\beta t)$ .

### B. Circuit Parameters

Choose circuit parameters so that the following criteria are satisfied:

- 1)  $\psi = \pm 90^\circ$  to make second waveform  $b e^{-\alpha t} \cos(\beta t) + c$
- 2)  $a = b$
- 3)  $\frac{1}{\alpha} = 3T$  where  $\beta = 2\pi/T$  and  $T$  is the period of oscillation.
- 4)  $\alpha = 1\text{k/s}$

The first requirement makes  $v_1(t)$  and  $v_0(t)$  damped sinusoids that differ in phase by  $90^\circ$ . The second requirement makes the amplitudes equal. The third requirement makes the waves damp out at a relative rate that gives a nice spiral, and the fourth requirement makes the damping somewhat faster than the 100 Hz rate of the square wave driving the circuit.

Be sure that the total series resistance is large enough that the generator is not loaded excessively (the current is not too high) because excessive loading will distort the generator waveform. Assume the input to the circuit is a square wave that is 2 V high, peak-to-peak. That is,  $-1$  V and  $+1$  V.

### C. Double Spiral

Use Matlab® to plot the spirals that you expect on the oscilloscope by letting  $x = v_0(t)$  and  $y = v_1(t)$  and plotting  $y$  versus  $x$ . Do this for at least one full period of oscillation both when  $v_1(t)$  is positive and when it is negative. Be sure you understand fully how the spirals are produced on the screen when  $v_0(t)$  and  $v_1(t)$  are connected to the horizontal and vertical inputs, respectively. Also, write your Matlab® code so that you can easily change the period of  $v_1(t)$  when you superimpose measured data later on.

## VIII. CONSTRUCTION AND TESTING OF SPIROGRAVITATOR CIRCUIT

### A. Circuit Construction

Construct a breadboard version of the circuit in Fig. 1 using the component values that you have selected.

### B. Display $v_0(t)$ and $v_1(t)$

Display  $v_1$  and  $v_0$  simultaneously on a dual-trace oscilloscope and verify that  $v_1$  is a good square wave and that the period of  $v_1$  is enough longer than the decay time of  $v_0$  that the natural response of  $v_0$  is negligible after half a period of  $v_1$ .

Display  $v_0$  and  $v_1$  simultaneously on a dual-trace oscilloscope and check to see that they are consistent with your calculations, but wait to make detailed measurements until you get the spiral graph to work. Be sure that  $v_0$  and  $v_1$  are  $90^\circ$  out of phase, and their amplitudes are equal. (If they are out of phase, the plot will be tilted, and if their amplitudes are unequal the plot will be ellipsoidal.)

### C. Display the Spirals

Connect  $v_0$  and  $v_1$  appropriately to the x-y inputs of an oscilloscope, (i.e., the two channels of input to the scope, with the scope set to display in x-y mode). Adjust the amplitude of  $v_1$  to 1V zero-to-peak, and set the generator frequency to 100 Hz. You should see the double spiral pattern on the oscilloscope.

### D. Measure $v_0(t)$ and $v_1(t)$

Display  $v_0$  and  $v_1$  again with the dual trace, and save the waveforms for use in Matlab® later on. Then measure  $\alpha$ ,  $\beta$ ,  $a$ ,  $b$ ,  $c$ , and  $\psi$  to compare with your calculations. Think carefully about how best to do this. Also, measure the actual values of your components and use the measured values in your calculations to get the best correspondence with measurements.

### E. Comparison of $v_0(t)$ and $v_1(t)$

Compare the calculated and measured values of  $v_0(t)$  and  $v_1(t)$  by plotting measured and calculated values of  $v_0(t)$  and  $v_1(t)$  on the same set of axes.

## IX. NOTEBOOK AND REPORT

Turn in a copy of your laboratory notebook pages and a separate formal report. Refer to the grading information on the course website for the section numbering to use while writing the formal report. Use the IEEE format for typesetting. Information about the IEEE format, including a template file, is available on the course website. Additional information about writing the report and keeping a notebook is listed in the *Course Procedure* on the course website. Note that Matlab® plots, if they are listed in the contents of the report, must appear both in the laboratory notebook *and* the formal report.