



Abstract-You will construct and test two LED power-indicator circuits for your breadboard in preparation for building the Electromyogram circuit in Lab 1b.

I. PREPARATION

For Lab 1a, which will last about one week, you will need the parts listed in Table I. You may purchase these parts from the stockroom next to the lab or purchase them elsewhere.

TABLE I
PARTS LIST

Item	Qty	Description
1	1	Breadboard
2	1	Breadboard Wire Kit
3	2	1 k Ω Resistor
4	2	Red LED
5	1	Green LED

II. LEARNING OBJECTIVES

- 1) Learn about Kirchhoff's Laws and Ohm's Law
- 2) Learn how to build and circuits: LED power indicators
- 3) Learn about the current versus voltage characteristics of an LED

III. INTRODUCTION

In Labs 1a and 1b, you will build an electromyogram circuit to measure the tiny voltages produced by muscles. The gross muscle groups (e.g., biceps) in the human body are composed of a large number of parallel fiber bundles functionally arranged into individual motor units. When each motor unit is activated by nerve commands (action potentials) from the central nervous system, electrical impulses propagate down the length of the fibers that make up the unit. The electrical impulses can be picked up by electrodes and converted to voltages. A plot of the voltages from the muscles is called an *electromyogram*, or EMG ("myo" is a root meaning "muscle"). Fig. 1 shows the system for measuring an EMG.

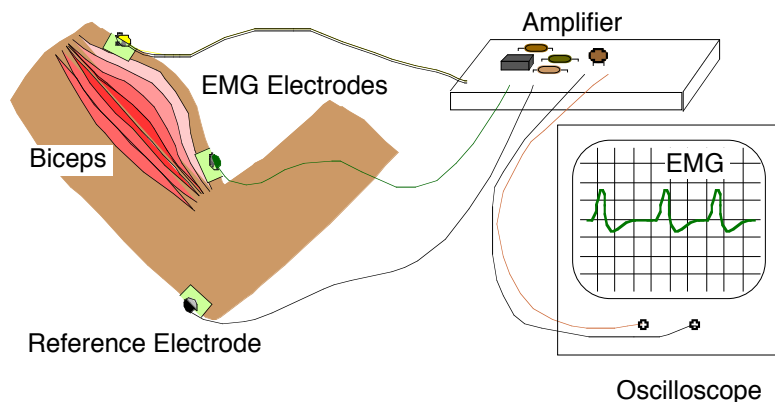

Figure 1. System for measuring an electromyogram.

For the first part of Lab 1, which we call Lab 1a, you will be given explicit directions describing how to build LED (Light Emitting Diode) power-indicator circuits that will be part of the final electromyogram circuit. A red LED will light up when +12V is turned on, and a green

LED will light up when -12V is turned on. These two voltages are needed for the EMG circuit you will build later. It is helpful to use visual indicators showing when power is present. A power supply in the lab will produce the $+12\text{V}$ and -12V power. The power supply is equivalent to two 12V batteries, such as those used in cameras. After constructing the LED circuits, you will make measurements to find current-versus-voltage characteristics of the LED's.

For the second part of Lab 1a, you will be given explicit directions describing how to build pre-amplifier circuits for the final electromyogram circuit. For this part of Lab 1a, you will use an integrated circuit operational-amplifier (op-amp) that you will treat as a circuit block known only by its pin numbers. Lab 1b will describe the op-amp in a bit more detail.

IV. CONSTRUCTION OF LED POWER INDICATORS

Fig. 2a shows how to put the components on the breadboard to build the LED power indicators. The red circle in Fig. 2a is a red LED, and the green circle in Fig. 2b is a green LED. One side of the LED goes in row 4, and the other side of the LED goes in row 5. Also shown is a $1\text{ k}\Omega$ resistor with brown, black, and red stripes. The wire colors indicate the lengths of wires using the same color code as resistors. Ignore the alligator clips at present; you will connect them after you build the circuit. Note that the breadboard has metal clips inside that connect certain holes to each other so that components inserted into those holes are automatically connected to one another. The gray line segments between holes in Fig. 2a show which holes are connected together. If you follow the wires, you can show that you obtain the schematic shown in Fig. 2b.

Build the circuit shown in Fig. 2a. You will connect power later.

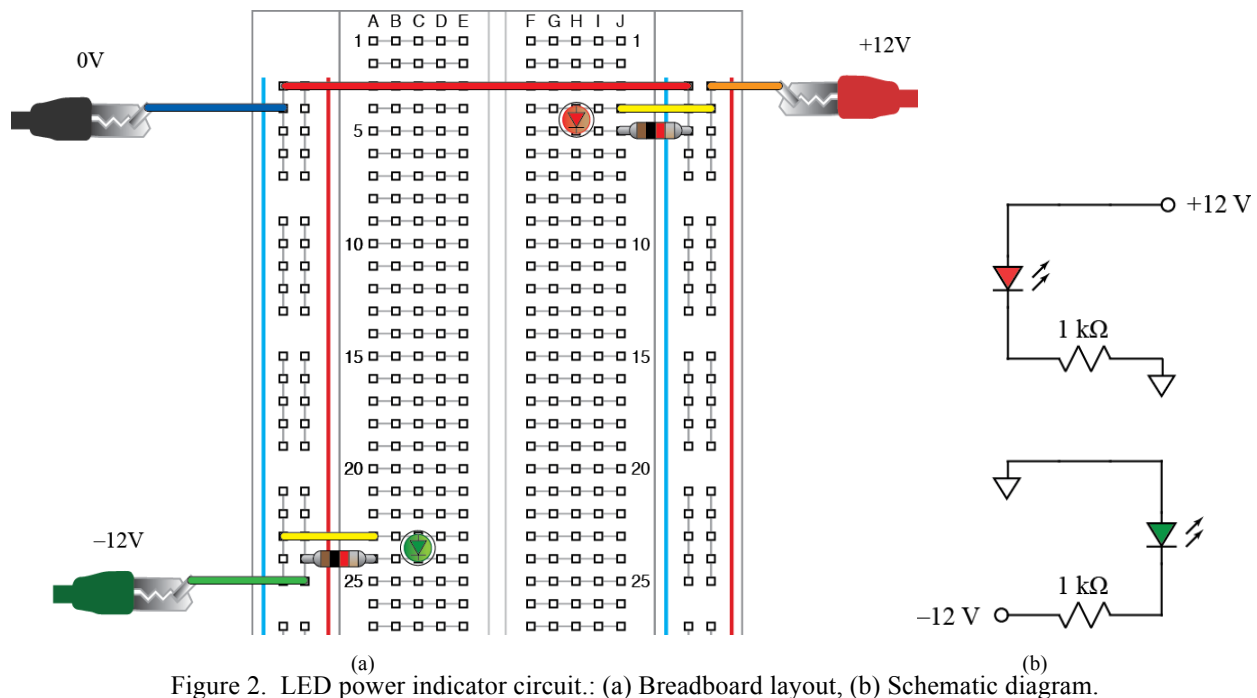

Figure 2. LED power indicator circuit.: (a) Breadboard layout, (b) Schematic diagram.

Fig. 3 shows how to hook up leads to the power supply. The power supply has so-called “banana plugs” to which cables with a banana plug at one end (and alligator clips at the other end) are connected. Whenever possible, we use certain cable colors to represent certain voltages. In the present case, we use red for $+12\text{V}$, black for 0V , and green for -12V . Unfortunately, the banana-plug cables in the lab are available only in red and black. Furthermore, the cables are in

pairs connected with cable ties. The photo shows how one black cable lies unused on the left side, and a red cable is connected to a green alligator clip on the right side.

Before connecting the alligator clips to the breadboard circuit, turn on the power supply and adjust the outputs of the +25 V and -25 V supplies to +12 V and -12V. Note the power supply is equivalent to three adjustable batteries. One “battery” is adjustable from 0V to 6V, a second battery is adjustable from 0V to +25V, and a third battery is adjustable from 0V to -25V. (A negative voltage is the same as using a battery backwards.) To adjust the three different batteries, you must turn on the power supply output (using a button on the front panel) and then tell the power supply which voltage you wish to adjust. Press the button on the front panel corresponding to the voltage you wish to change, and you will see that the display shows that voltage. The gray knob and the > and < buttons below it allow you to adjust the output voltages. Adjust the +25 V and -25 V supplies to +12 V and -12V and turn the output off again. (Be sure the alligator clips for the outputs do not touch one another. If they touch, no harm will probably be done, but the output voltage will drop to zero and you will be unable to adjust the voltage as desired.)

Now connect the three alligator clips from the power supply to the breadboard as indicated in Fig. 2a and press the button on the power supply to turn on the +12V and -12V signals. If either of your LEDs fail to light, try reversing the direction of the LED in the circuit. If the LEDs still fail to light, use a voltmeter on the DCV setting to measure the voltages across pairs of power supply leads. You should get $\pm 12V$ or $\pm 24V$, depending on which pair of power supply leads you measure. If this also fails, try disconnecting the power leads from your circuit and measuring again. If the voltages are now present, you have probably made a wiring mistake that shorted out the power. If so, look at your circuit very carefully and verify that it matches Fig. 3a exactly.

If you are still having trouble, consult with your TA to get more trouble-shooting tips.

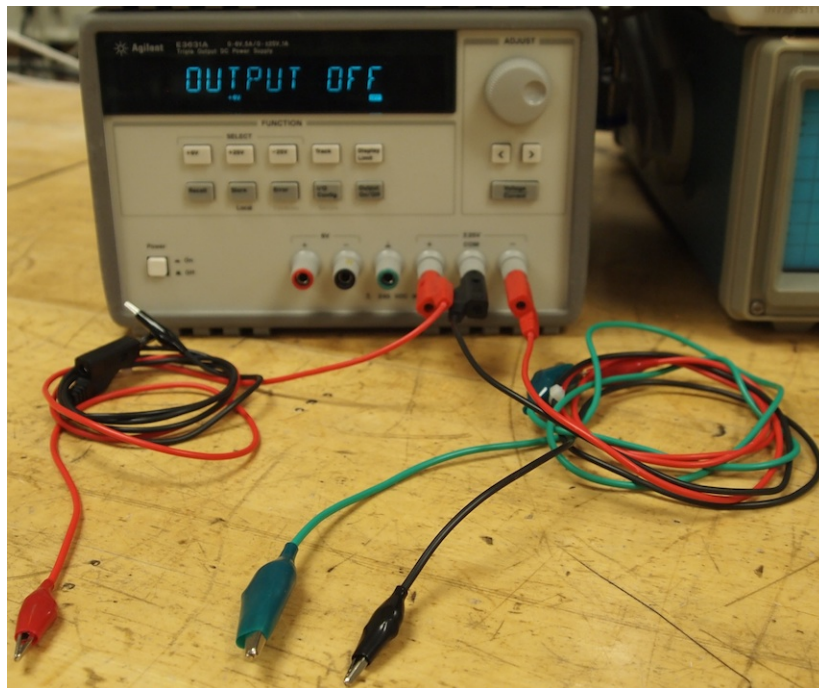

Figure 3. Power supply leads.

V. RESISTOR AND LED CURRENTS

A. Measurements of Voltages

Using the Agilent multimeter, as shown in Fig. 4, you will make measurements of voltages across the resistor and LED in the +12V power indicator circuit you have built. To make a voltage measurement, turn on the multimeter and press the **DC V** button. You can then measure the voltage across any component by placing the red probe on one side of the component and the black probe on the other side of the component. (Holding both probes in place at the same time sometimes requires considerable dexterity.) Notice that in Fig. 4, even when the probes are disconnected, they register a nonzero voltage. The voltage reading is millivolts, however, meaning it is miniscule. This voltage reading is so small that it varies randomly. It is measuring tiny disturbances called noise that occur all the time. Because of noise, it is important to pay attention to how stable measurements are. If a digit in the reading is constantly changing, it is inaccurate, and the reading should be rounded off to fewer digits.

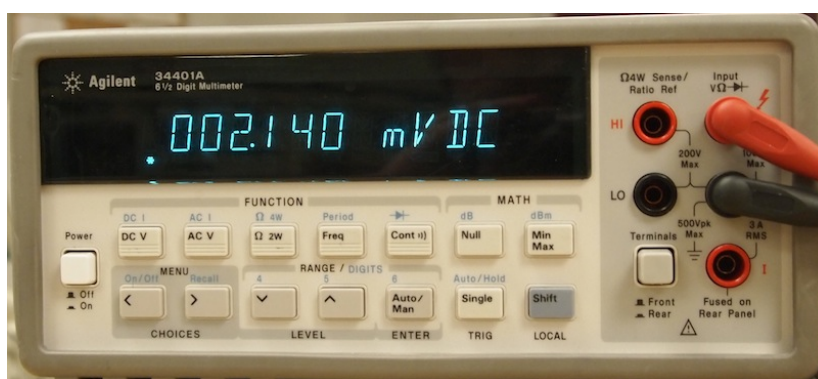

Figure 4. Agilent Multimeter

Using the buttons and knob on the power supply, change the +12V supply to at least five different values distributed (roughly uniformly) between 0 V and +12 V and measure the voltage across both the 1 kΩ resistor and LED in the +12V power indicator circuit. (If your readings give negative values, reverse the probes.) Make a copy of Table II, below, in your notebook and enter the values you measure. (Use the power supply display for the power supply voltage.)

TABLE II
+12V POWER INDICATOR CIRCUIT VOLTAGES

Power Supply Voltage (V)	Resistor Voltage (V)	LED Voltage (V)

B. Calculation of Current in Resistor and LED

By Kirchhoff's current law, the current that flows through the resistor must also flow through the LED. Thus, the LED current equals the resistor current. By Ohm's law, the current in the resistor is a function of voltage, as in (1):

$$i = \frac{v}{R} \quad (1)$$

The LED does *not* obey Ohm's law, as you will now show. Using your values from Table II and (1), compute the current in the LED for each of power supply voltages in Table II. Fill out Table III with these current values and copy the other columns from Table II. Note that, to make your calculations, you need the value of R . Use the Agilent multimeter to measure your 1 k Ω resistor. Use the button labeled Ω on the multimeter and place the probes across the resistor *after you have taken the 1 k Ω resistor out of the circuit*. (If you leave the resistor in the circuit, it is connected to other devices through which current could flow, which could affect the measurement.) Note the value of the resistor in your notebook and replace it in the circuit. Then complete Table III. Remember to use engineering units for your calculations and values.

TABLE III
LED CURRENT AND VOLTAGE

Power Supply Voltage (V)	LED Voltage (V)	LED Current (A)

C. Plot of Current versus Voltage in LED

Plot *by hand* the values of LED current (y values) versus LED voltage (x values). Use graph paper in your notebook or draw a square grid in your notebook for the plot. Choose an appropriate scale for x and y and label the horizontal axis with both a description (such as "LED voltage") and units in parentheses (such as "(V)"). Draw circles around the data points as you plot them and, when you are done, connect the data points with line segments and add a title to your plot.

Note that the plot you have made is nonlinear. The LED current versus voltage is described by an exponential equation. In practice, we approximate the behavior of the LED by assuming its voltage is constant, regardless of how much current is flowing through it. Your plot will show that this is not quite true, although it is usually accurate enough for designing an LED circuit.

VI. CONSTRUCTION AND TESTING OF PRE-AMPS

A. Construction

Using the diagram in Fig. 5a, construct the two pre-amp circuits whose schematic diagram is shown in Fig. 5b. The LF353 is an op-amp IC that you may purchase in the stockroom (or elsewhere). Note that all points in the circuit marked with a triangle, meaning they are at 0V, are connected together. Note also, that there are two very short vertical wires near the op-amp chip.

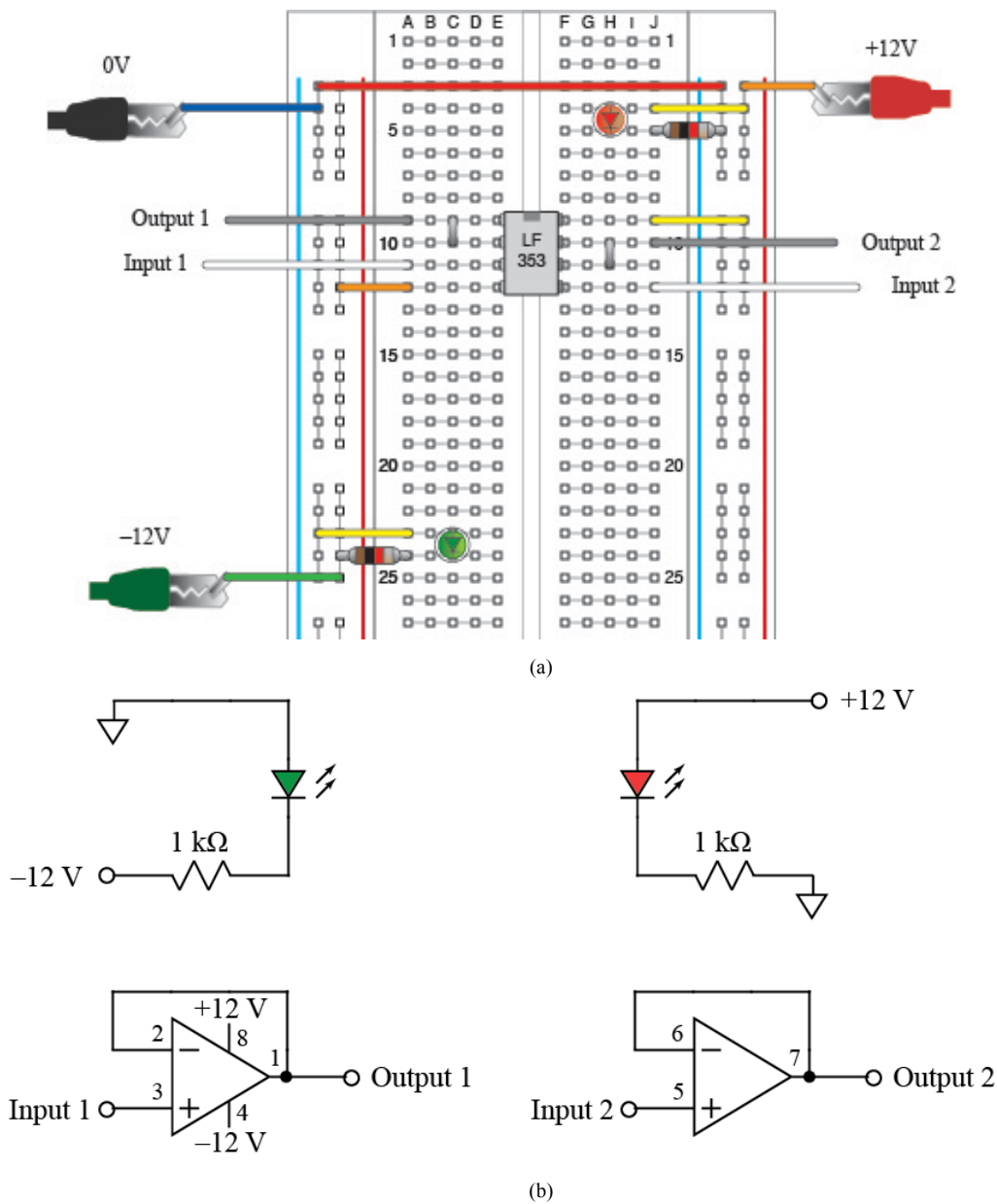

Figure 5. Pre-amp circuits: (a) Breadboard layout, (b) Schematic diagram.

To test the op-amp circuit, you will use a function generator and an oscilloscope. Fig. 6 shows how to connect leads to the function generator and oscilloscope in preparation for making measurements. After making the connections shown in Fig. 6, connect all the black leads to 0V, which is running all the way down the leftmost column of the breadboard. Add wires for connections as needed. Connect the function generator output (red alligator clip) to “Input 1” on the breadboard. Also, connect the red alligator clip for input 1 on the oscilloscope to “Input 1” on the breadboard. Input 1 of the oscilloscope will show the waveform from the function generator. Connect the red alligator clip for input 2 on the oscilloscope to “Output 1” on the breadboard. Input 2 of the oscilloscope will show the waveform coming out of the pre-amp.

Turn on the function generator and oscilloscope and use the “ampl” button on the waveform generator and the knob and < and > buttons to change the output voltage to 1V. Then press the “Auto Scale” button the oscilloscope to see the waveform. If all goes well, you will see a two sinusoids that are the same size.

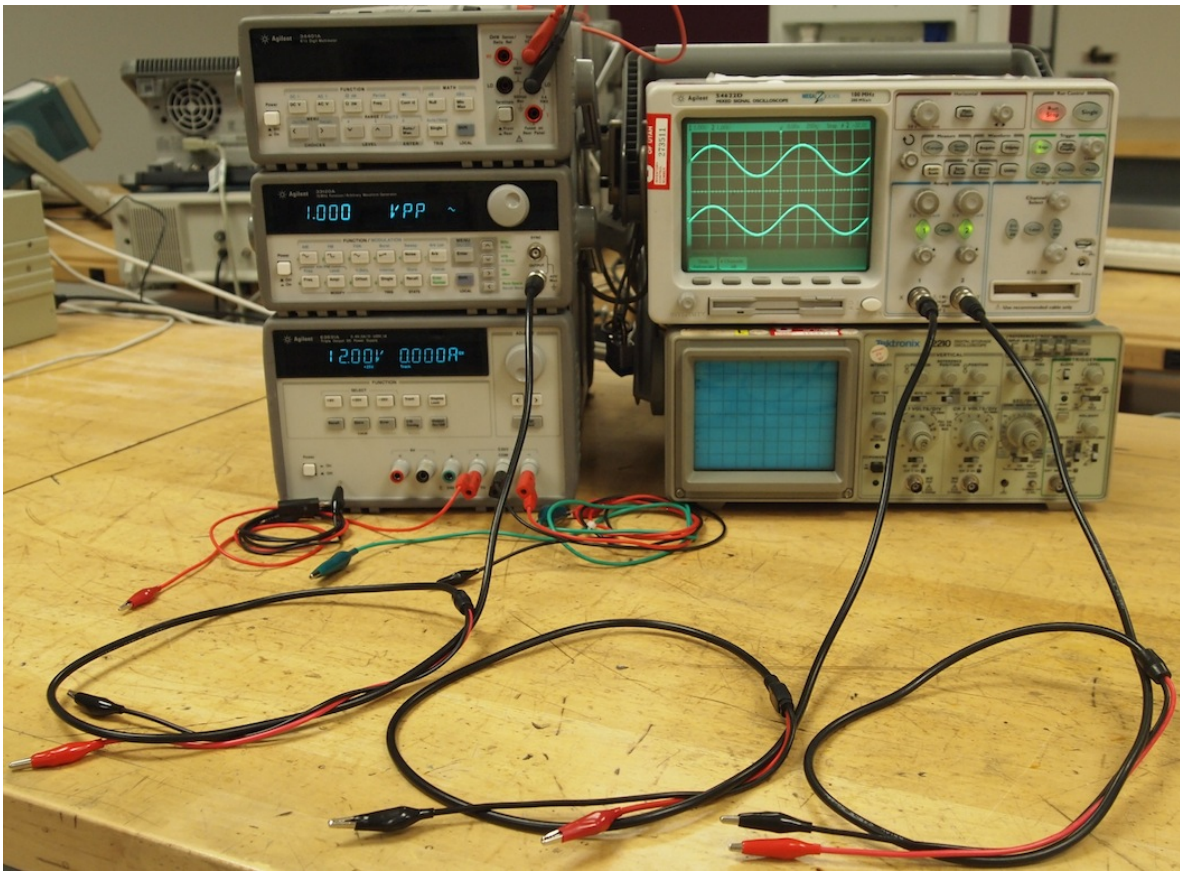

Figure 6. Waveform generator and oscilloscope connections.

B. Drawing of Waveforms

Make a careful drawing of the oscilloscope screen, showing the scale for the horizontal axis (time) and the vertical axis (voltage). The time and voltage represented by one box is printed on oscilloscope screen. Be careful to include the value of each in your drawing.

This completes Lab 1a. You will now write up a portion of this part of Lab 1 according to the handout entitled “Lab 1a Report Contents and Grading” that will be posted on the course website.