

Ex: Determine whether each of the following circuits is valid or invalid.

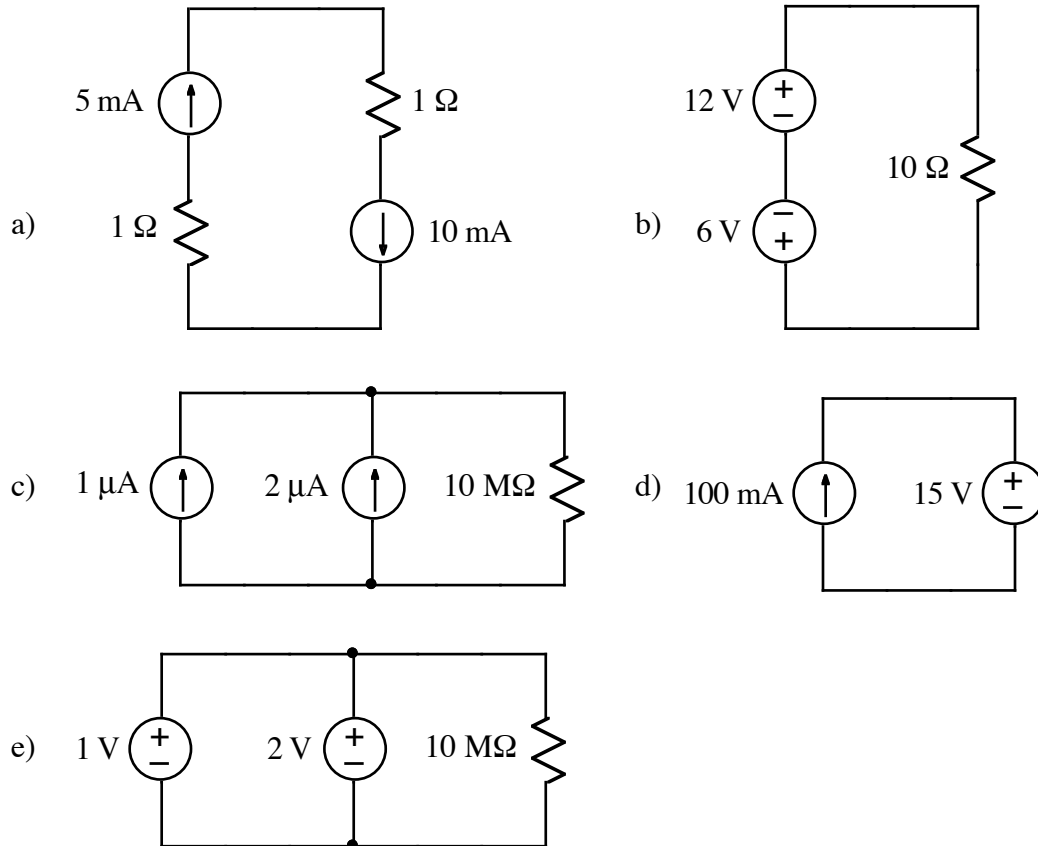

- SOL'N:**
- a) Circuit is invalid. By Kirchhoff's laws components in series must carry the same current. The current sources disagree on the current and will try to force the current to have two different values: 5 mA and 10 mA.
 - b) This circuit is valid. Voltage sources in series sum. Here, the voltage across the $10\ \Omega$ resistor is $12\ \text{V} - 6\ \text{V} = 6\ \text{V}$. The current in the $10\ \Omega$ resistor is $600\ \text{mA} = 6\ \text{V} / 10\ \Omega$. Note that voltage sources can pass whatever current is necessary in order to create a specified voltage in a circuit.
 - c) This circuit is valid. Current sources in parallel sum. Here, the current flowing through the $10\ \text{M}\Omega$ is $1\ \mu\text{A} + 2\ \mu\text{A} = 3\ \mu\text{A}$. The voltage across both current sources is $3\ \mu\text{A} \cdot 10\ \text{M}\Omega = 3\ \text{V}$. Note that current sources

will produce whatever voltage is necessary to force a specified current flow in a circuit.

d) This circuit is valid. The current source has -15 V across it, and the voltage source has -100 mA flowing through it.

e) This circuit is invalid. By Kirchhoff's laws, components in parallel must have the same voltage drop across them. Here, the two voltage sources disagree what voltage drop there should be across the $10\text{ M}\Omega$ resistor.