

Ex:

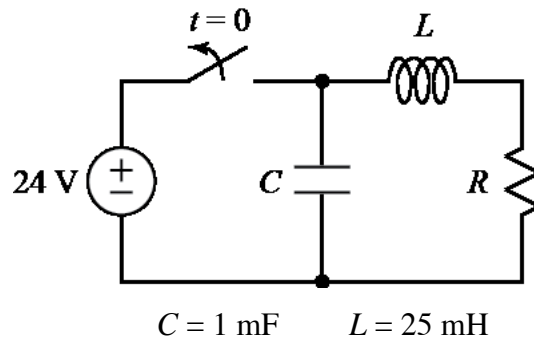

A relay is driven by a 24 V power supply, as shown above. Power is turned off at $t = 0$. The current, $i(t)$, for $t > 0$ has two terms that decay exponentially without oscillation. One term dies out quickly, and the other term dies out with a time constant of $\tau = 10 \text{ ms}$, as in $e^{-t/10\text{ms}}$. Given the time constant and the information in the diagram above, find the value of R .

sol'n: From what we are told, we have one characteristic root equal to $-1/10\text{ms}$.

Since the circuit is a series RLC, we use $\alpha = R/(2L)$.

As always, $\omega_0^2 = 1/(LC)$.

Our characteristic roots are

$$s_{1,2} = -\alpha \pm \sqrt{\alpha^2 - \omega_0^2}$$

The problem states that the ^{term for the} root equal to $-1/10\text{ms}$ dies out more slowly. This means the magnitude of this root is smaller. This is, therefore, the root corresponding to

$$s = -\alpha + \sqrt{\alpha^2 - \omega_0^2}$$

So we have $s = -\alpha + \sqrt{\alpha^2 - \omega_0^2} = -1/10\text{ms}$.

We solve for R.

$$-\frac{R}{2L} + \sqrt{\left(\frac{R}{2L}\right)^2 - \frac{1}{LC}} = -\frac{1}{10\text{ms}} = -100$$

We get the $\sqrt{\quad}$ by itself on one side by adding $\frac{R}{2L}$ to both sides.

$$\sqrt{\left(\frac{R}{2L}\right)^2 - \frac{1}{LC}} = -100 + \frac{R}{2L}$$

We now square both sides.

$$\left(\frac{R}{2L}\right)^2 - \frac{1}{LC} = +100^2 - 2(100)\frac{R}{2L} + \left(\frac{R}{2L}\right)^2$$

$$\text{where } \frac{1}{LC} = \frac{1}{25\text{m} \cdot 1\text{m}} = \left(\frac{1}{5\text{m}}\right)^2 (\text{r/s})^2$$

or

$$\frac{1}{LC} = 200^2 \text{ r}^2/\text{s}^2$$

We rearrange to get R by itself on one side.

$$200 \frac{R}{2L} = 100^2 + 200^2 = 50\text{k} \text{ r}^2/\text{s}^2$$

$$R = 50\text{k} \cdot \frac{2L}{200} \quad \Omega/\text{H}$$

$$R = \frac{50\text{k}}{200} \cdot 2(25\text{m}) = \frac{25}{2} \Omega$$

or

$$R = 12.5 \Omega$$