

Ex:

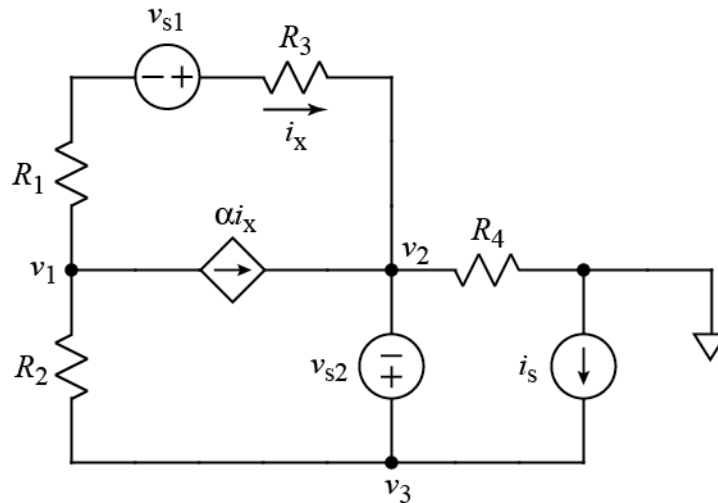

For the circuit shown, write three independent equations for the node voltages v_1 , v_2 , and v_3 . The quantity i_x must not appear in the equations.

SOL'N: For the v_1 node on the left:

$$\frac{v_1 + v_{s1} - v_2}{R_1 + R_3} + \alpha \frac{v_1 + v_{s1} - v_2}{R_1 + R_3} + \frac{v_1 - v_3}{R_2} = 0 \text{ A}$$

Note that i_x is the same as the current in the top branch from v_1 to v_2 . We substitute this current for i_x in the middle term.

Nodes v_2 and v_3 form a super-node. The voltage equation for the nodes is

$$v_2 + v_{s2} = v_3.$$

The current summation for the super-node is formed by all currents flowing out of the v_2 and v_3 nodes except those flowing in v_{s2} :

$$\frac{v_2 - v_{s1} - v_1}{R_1 + R_3} + \alpha \frac{v_2 - v_{s1} - v_1}{R_1 + R_3} + \frac{v_2}{R_4} + \frac{v_3 - v_1}{R_2} - i_s = 0 \text{ A}.$$

This complete the set of three equations.