

Circuit Transients

A Stolp
3/29/01,
9/29/04

1.1 Introduction

Transient: A transient is a transition from one state to another. If the voltages and currents in a circuit do not change with time, we call that a "steady state". In fact, as long as the voltages and currents are steady AC sinusoidal values, we can call that a steady state as well. Up until now we've only discussed circuits in a single steady state. But what happens when the state of a circuit changes, say from "off" to "on"? Can the state of the circuit change instantaneously? No, nothing ever changes instantaneously, the circuit state will go through some transition from the initial state, "off" to the final state, "on" and that change will take some amount of time. The same is true in mechanical systems. If you want to change the velocity of a mass or the level of fluid in a tank or the temperature of your coffee, that transition from one state to another will take some time.

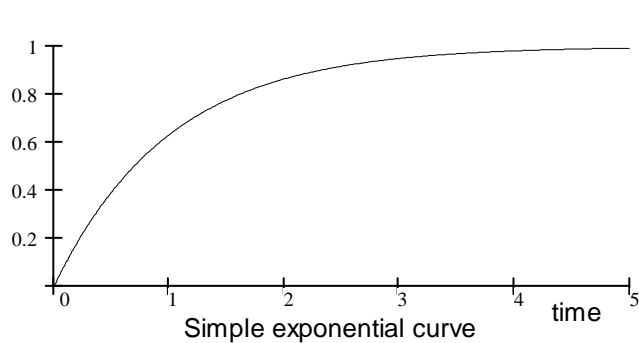

Simple exponential curve

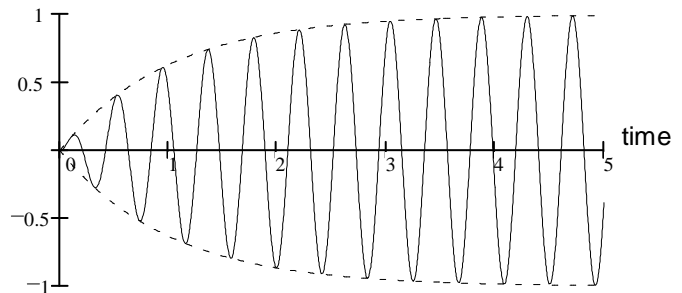

An exponential buildup of a sine wave

The drawings on this page show some typical transients that can occur when a circuit is first turned on. The initial state of all the waveforms is 0. The final state is either 1 or a sine wave with an amplitude of 1. Notice that in all four cases the transient effects decay exponentially and that all four waveforms have pretty nearly reached their steady-state values by the end of the graph.

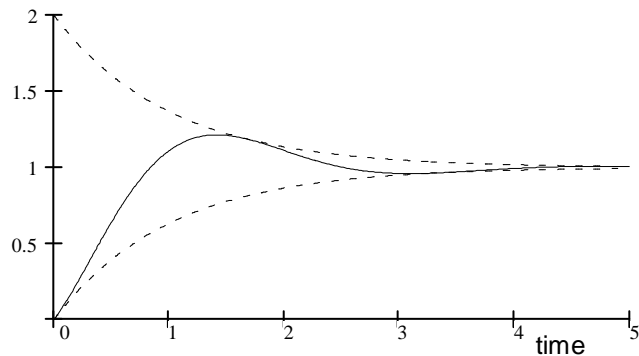

Overshoot

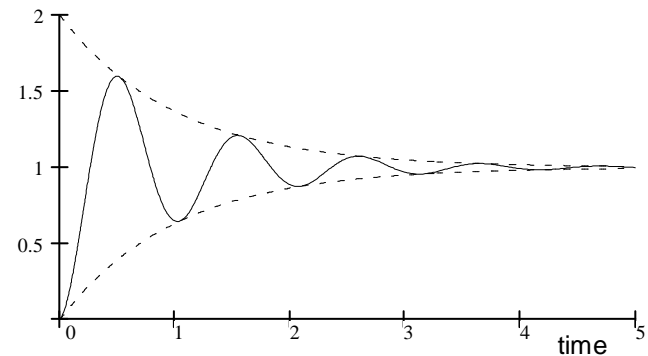

Ringing

Transient analysis: Needless to say, the analysis of these transients is a bit more involved than the steady state. In fact, it usually involves two steady state analyses just to find the initial and final states of the circuit, and then you still need to figure out what happens in between.

Transients are not instant because capacitors and inductors in the circuit store energy, and moving the energy into or out of these parts takes some time. The voltage-current relationships of capacitors and inductors are differential equations, so transient analysis will involve solving differential equations. But don't panic, you'll learn some nice tricks and techniques for dealing with these equations—tricks and techniques that you can use in any engineering field, not just EE. Actually, all that phasor stuff you used with AC circuits was also a trick to simplify the differential equations, unfortunately, that trick only works for sinusoids in steady state.

DC circuits with only resistors also experience transients, but these are due to non-ideal capacitance and inductance of the parts and wires that we haven't considered before. These transients happen so fast that we won't worry about them.

Importance: So why are transients important? Two reasons really. DC and steady-state AC are fine for moving and using electrical power, but sometimes you need to turn them on and off and you may need to know what happens at those times. That need turns out to be relatively rare and probably couldn't justify the time we'll spend studying transients. It's signals processing and control systems really drive our study of transients.

Signals are electrical voltages and currents that carry information. The information could be audio or video or the information might be about the position or speed of mechanical parts, or about the temperature or level of fluids or chemicals or practically anything you can imagine. To carry information signals have to change in some way that we can't predict and we'll need to have some idea how a circuit will respond to those changes. Changes are transients. However, since these changes can't be known beforehand we usually find a circuit's response to specific types of inputs and then draw conclusions about the effectiveness or stability in the general case. Often the electrical circuit is just one part of a larger system that may include mechanical, hydraulic, or thermal systems. See box.

Printer Design

Lets think about some of the transients and signals involved with moving a print head and putting ink on a page of paper.

First, there's the mechanical system to move the print head. How quickly does the movement respond to an electrical signal sent to the motor? How powerful do those signals have to be? Does it have a natural frequency where it might vibrate or oscillate? These are all questions for the transient analysis of the mechanical system.

The electrical circuit would take a signal from some sensor that indicates the position of the print head and, using other information about where the next character should be printed, send the right signals to the motor. You'd use transient analysis to make sure that it could handle any combination of inputs without overshooting the position or oscillating or going too slowly. Besides this, the electrical system may have to compensate for properties of the mechanical system.

Finally, there's the system that actually puts the ink on the paper, let's say it's an ink jet. Transient considerations here would include the time it takes for the print head to heat the ink to the point where it spits a bubble and how that should all be timed with the head movement to place that bubble on the paper at just the right place.

1.2 First-order transients

Analysis of a circuit with only one capacitor or one inductor results in a first-order differential equation and the transients are called first-order transients.

Series RC circuit, traditional way: Look at the circuit at right. It shows a capacitor and a resistor connected to a voltage source by way of a switch that is closed at time $t=0$. Before the switch is closed the current $i(t)$ and the voltage v_R are both 0, but the voltage v_C is unknown. Remember a capacitor is capable of storing a charge, so we don't know what its charge might be unless we or can measure it or its is given. I'll call it the initial voltage ($v_C(0)$). Because the voltage across a capacitor cannot change instantaneously, the voltage across the capacitor just after the switch closes must be the same as it was just before the switch closes.

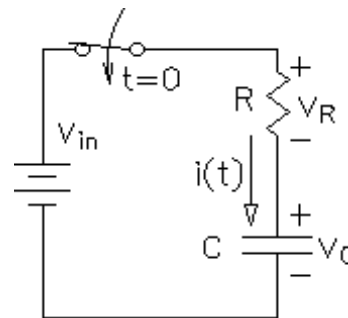

Now we just have to apply the basic circuit laws

$$V_{in} = v_R + v_C \quad i \cdot R + v_C = i \cdot R + \frac{1}{C} \int_{-\infty}^t i_C dt \quad \text{Making the obvious substitution.}$$

The next step here would be to differential both sides of the equation, but if you're a little more clever, there's an easier way, check this out:

Make this substitution instead $i = i_C = C \cdot \frac{d}{dt} v_C$, to get $V_{in} = R \cdot C \cdot \frac{d}{dt} v_C + v_C$

Waa-laa, no integration. Always try to write your differential equations without integrals, it will eliminate one more source of mistakes. We now have a differential equation in terms of v_C . If v_C isn't the variable we want to find in our analysis then we can always go back to the circuit later and find the current or the voltage v_R by simple circuit analysis *after* we've found v_C .

Transients p. 1.2

So now we have to solve the differential equation. Recall from your differential equations class that first order differential equations are always solved by equations of the following form.

Standard first order differential equation answer: $v_C(t) = A + B \cdot e^{-s \cdot t}$

And, by differentiation: $\frac{d}{dt} v_C = B \cdot s \cdot e^{-s \cdot t}$

Substitute these back into the original equation:

$$V_{in} = R \cdot C \cdot \frac{d}{dt} v_C + v_C = R \cdot C \cdot B \cdot s \cdot e^{-s \cdot t} + (A + B \cdot e^{-s \cdot t}) = R \cdot C \cdot B \cdot s \cdot e^{-s \cdot t} + B \cdot e^{-s \cdot t} + A$$

We can separate this equation into two parts, one which is time dependent and one which is not. Each part must still be an equation.

Time independent (forced) part: $V_{in} = A$, $A = V_{in} = \text{final condition} = v_C(\infty)$

Time dependent (transient) part: $0 = R \cdot C \cdot B \cdot s \cdot e^{-s \cdot t} + B \cdot e^{-s \cdot t}$,

Divide both sides by $B \cdot e^{-s \cdot t}$ to get $0 = R \cdot C \cdot s + 1$, $s = -\frac{1}{R \cdot C} = -\frac{1}{\tau}$, where $\tau = R \cdot C$

This τ is called the "time constant" and will become a rather important little character.

Put the parts we know back into the expression for $v_C(t) = V_{in} + B \cdot e^{-\frac{t}{R \cdot C}} = v_C(\infty) + B \cdot e^{-\frac{t}{R \cdot C}}$

at time $t = 0$: $v_C(0) = V_{in} + B$, $B = v_C(0) - V_{in} = v_C(0) - v_C(\infty)$ **B is the difference between v_C at the start and v_C at the end.**

And finally: $v_C(t) = V_{in} + B \cdot e^{-\frac{t}{R \cdot C}} = v_C(\infty) + (v_C(0) - v_C(\infty)) \cdot e^{-\frac{t}{R \cdot C}}$

It turns out that all first-order transient solutions will have the same form, just different variables and time constants.

Once you have $v_C(t)$, you can also find $v_R(t)$ and/or $i(t)$ from $v_C(t)$ if you want.

$$v_R(t) = V_{in} - v_C(t) = V_{in} - \left(B \cdot e^{-\frac{t}{R \cdot C}} + V_{in} \right) = -B \cdot e^{-\frac{t}{R \cdot C}} = -B \cdot e^{-\frac{t}{\tau}} = (v_C(0) - v_C(\infty)) \cdot e^{-\frac{t}{R \cdot C}}$$

$$i(t) = C \cdot \frac{d}{dt} v_C = -C \cdot B \cdot \frac{1}{R \cdot C} \cdot e^{-\frac{t}{R \cdot C}} = -\frac{B}{R} \cdot e^{-\frac{t}{\tau}} = \frac{-(v_C(0) - v_C(\infty))}{R} \cdot e^{-\frac{t}{R \cdot C}}$$

Let's plot these and see what they actually look like. These graphs show the capacitor charging from its initial value to V_{in} and v_R falling to 0 (same for i_R)

The curves are generalized based on the concept of the time constant, which is why we introduced the time constant. Later we'll look at these kind of curves in greater detail.

Ok, that was fun, but you might ask at this point if there isn't an easier way. Yes, in fact, there is. We'll look at next.

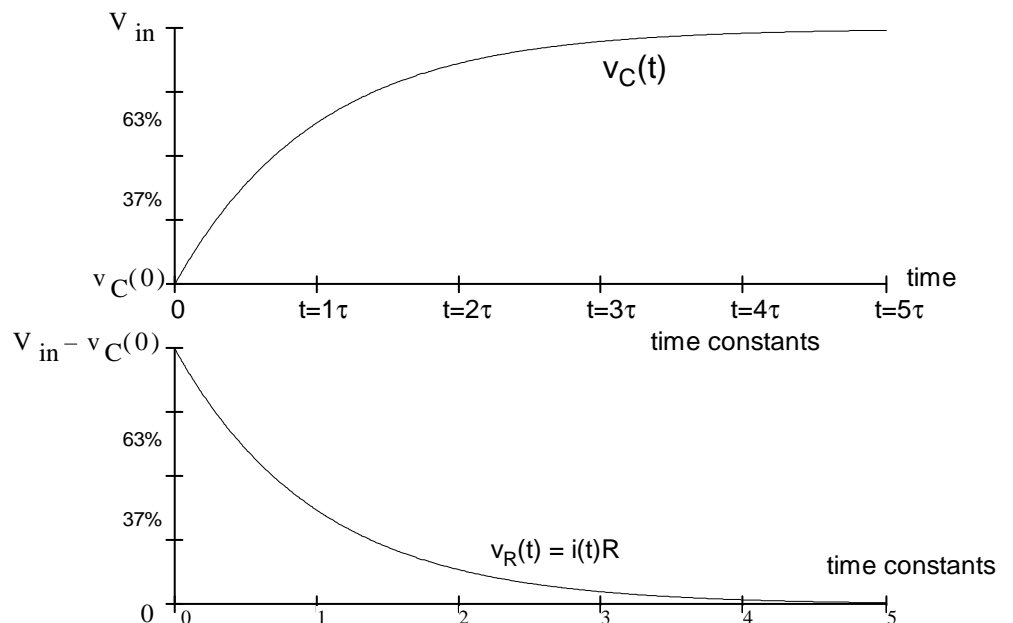

First-Order Transients the Easy Way

Notice in the preceding analysis that I made a very standard guess at the solution of the differential equation.

Standard first order differential equation answer: $v_C(t) = A + B \cdot e^{-s \cdot t}$

Further notice that A turned out to be the final condition and that B turned out to be the difference between the initial and final conditions. Finally, remember that I renamed s to $-1/\tau$. All of this can be generalized to any first order system. The answer will always be in this form:

For all first order transients:

$$x(t) = \underbrace{x(\infty)}_{\text{final condition}} + \underbrace{(x(0) - x(\infty))}_{\text{initial condition}} \cdot e^{-\frac{t}{\tau}} \quad \text{--- time constant}$$

$x(t)$ could be any variable in any first-order system. It could be a temperature, or a fluid level, or a velocity, but for us it usually means voltages and currents, so we'll have solutions like these.

$$v_X(t) = v_X(\infty) + (v_X(0) - v_X(\infty)) \cdot e^{-\frac{t}{\tau}} \quad \text{or} \quad i_X(t) = i_X(\infty) + (i_X(0) - i_X(\infty)) \cdot e^{-\frac{t}{\tau}}$$

You find Initial and final conditions from steady-state analysis. That leaves only one thing that you have to find from the differential equation-- the time constant. If we could only figure out what the time constant of a circuit (or system) is, then we could almost jump straight to the solution.

The first way to find the time constant is to simply remember it's form for a few cases, like the for RC circuit. Even if the circuit doesn't look exactly like the standard RC series circuit, Thevenin can help us make it look that way. Since nearly all of our first order circuits will involve a single capacitor or a single inductor this is not an impractical method at all.

Another way to find the time constant is to manipulate the differential equation into this particular form

$$\text{constant} = X + \tau \frac{dX}{dt} \quad \text{with no factor in front of the "X" term. Whatever the factor in front of } \frac{dX}{dt}$$

turns out to be, that will be τ . For the RC circuit the differential equation could be written as

$$V_{in} = R \cdot C \cdot \frac{d}{dt} v_C + v_C \quad \text{notice that the factor in front of } \frac{d}{dt} v_C \text{ is indeed } \tau.$$

Finally, there is an even easier way based on the LaPlace "s" and s-impedances that we can use in circuits and equations in place of differentials and integrals. You'll see this last method later, after second-order transients. (Incidentally, this is the reason that I chose to use an s as the unknown in the exponential.)

Series RL circuit: OK, if it's so easy, let's try it with a series RL circuit.

$$V_{in} = v_R + v_L \quad V_{in} = i \cdot R + L \cdot \frac{d}{dt} i \quad \frac{V_{in}}{R} = i + \frac{L}{R} \cdot \frac{d}{dt} i$$

So, the time constant must be $\tau = \frac{L}{R}$ That wasn't too bad.

Initial condition: $i_L(0) = 0$ If the switch was initially open the the current just before the switch was closed was 0, and inductor current can't change instantly.

Final condition: $i_L(\infty) = \frac{V_{in}}{R}$ The inductor looks like an short for steady-state DC.

$$\text{So: } i_L(t) = i_L(\infty) + (i_L(0) - i_L(\infty)) \cdot e^{-\frac{t}{\tau}} = \frac{V_{in}}{R} + \left(0 - \frac{V_{in}}{R}\right) \cdot e^{-\frac{R}{L} \cdot t} = \frac{V_{in}}{R} \cdot \left(1 - e^{-\frac{R}{L} \cdot t}\right)$$

Well, that's wasn't too painfull, was it?

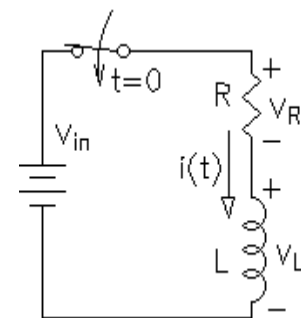

1.3 Initial and Final Conditions

More than once I've said that the initial and final conditions are found from steady-state analysis of the circuit. It's about time I said how.

Initial Conditions: There are two very important concepts that you use to find the initial conditions.

1) Capacitor voltage cannot change instantaneously, $v_C(0+) = v_C(0-)$.

If you can find the capacitor voltage just before time $t = 0$ (or whatever starts the transient), then you know what it is just after time $t = 0$, $v_C(0+) = v_C(0-)$. It cannot change instantaneously. Often you'll use the methods outlined below to find the final condition of the previous circuit, especially if the circuit's been in that condition for "a long time". Sometimes you'll have to solve the previous transient to find the initial condition for the next transient.

If you cannot find the capacitor voltage just before time $t = 0$ from the circuit, then you'll have to be told what the initial voltage or charge is. Capacitors can hold a charge for a long time, and can be moved from one circuit to another without losing the charge. High school electronics students like to charge capacitors and leave them where they'll shock some poor unsuspecting soul. Of course you'd never do something as childish as that. Occasionally you may be told what the initial charge is in terms of coulombs. In that case remember the definition of capacitance.

$$C = \frac{Q}{V} \quad \text{which can be rearranged to} \quad V = \frac{Q}{C}$$

If you have nothing else to go on, assume the initial voltage is 0.

2) Inductor current cannot change instantaneously, $i_L(0+) = i_L(0-)$.

If you can find the inductor current just before time $t = 0$ (or whatever starts the transient), then you know what it is just after time $t = 0$, $i_L(0+) = i_L(0-)$. It cannot change instantaneously.

If you cannot find the inductor current just before time $t = 0$ from the circuit, then assume it's 0. Real circuits and real inductors always have some resistance so inductor currents just don't last very long (unless you're dealing with superconductors). Inductors would be very difficult to move from one circuit to another without losing the current. If you're given an initial current for a problem, realize that this is probably just to make the problem more interesting, or the initial current comes from previous analysis.

Do not mix these two concepts up. Capacitor current and inductor voltage **can** both change instantly with no problem at all.

Final Conditions: This is steady-state analysis. The steady-state is the final condition.

DC sources

If all the voltage and current sources are DC, then at the final condition the capacitors are all done done charging so $i_C = 0$, and you can treat them as open circuits. When you find the voltage across the open, that will be the final capacitor voltage. You've done this sort of thing before to find the energy stored in a capacitor.

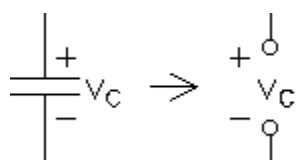

Replace capacitors with opens

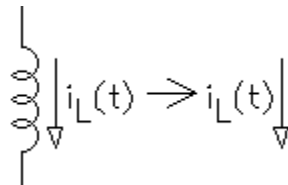

Replace inductors with wires

At the final condition the inductor currents are also no longer changing, so the voltage across an inductor is 0. Treat inductors as wires (short circuits). When you find the current through the wire, that will be the final inductor current.

AC sources

Use phasor analysis ($j\omega$). Remember that phasor analysis was also called "steady-state AC". One of the primary assumptions was that the transients had all died out.

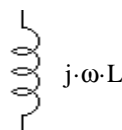
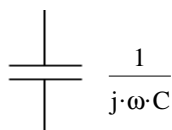

1.4 Exponential Curves

Before we go on to second-order transients we should take a closer look at some of the characteristics of exponential curves. The curves that show up as answers to our transient problems are shown below. The transient effects always die out after some time, so the exponents are always negative. Just think about what a positive exponent would mean. That wouldn't be a transient-- that would be exponential growth, like the population.

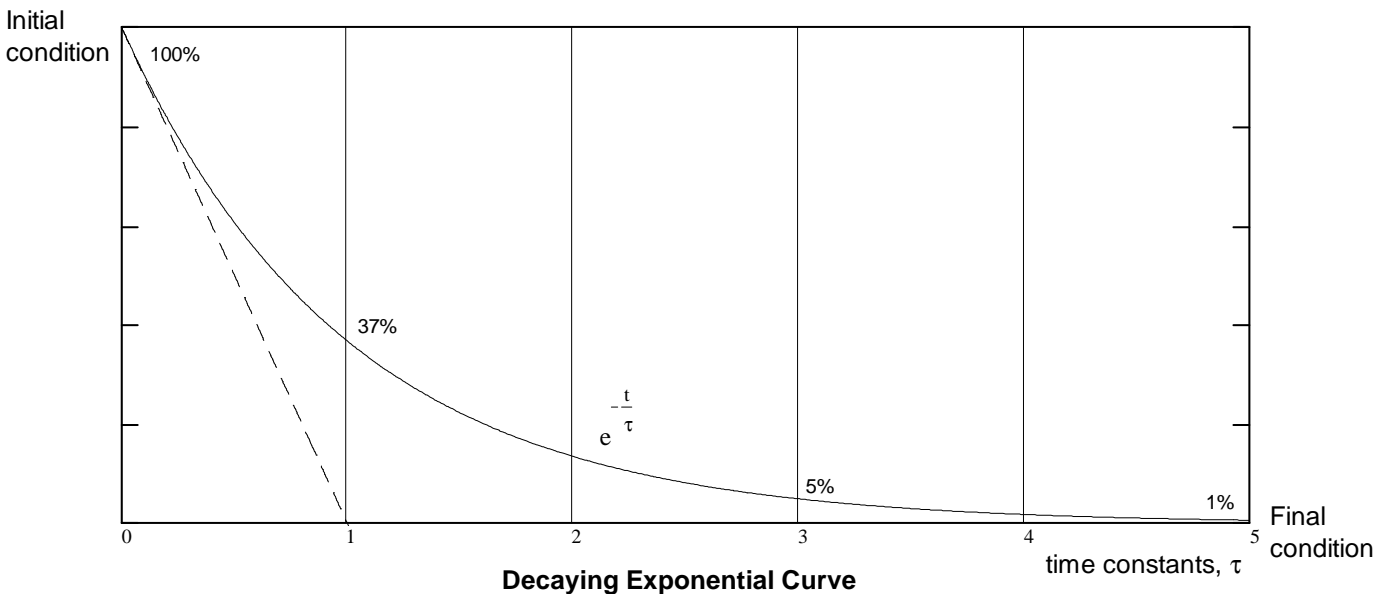
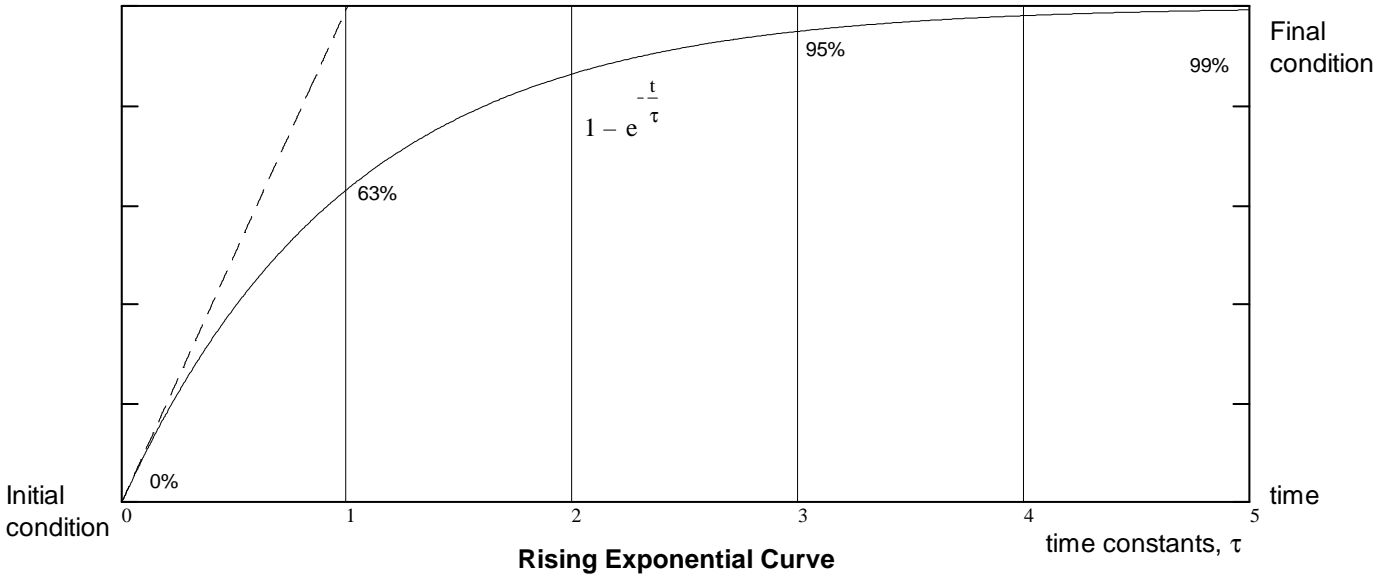

Some important features:

- 1) These curves proceed from an initial condition to a final condition. If the final condition is greater than the initial, then the curve is said to be a "rising" exponential. If the final condition is less than the initial, then the curve is called a "decaying" exponential.
- 2) The curves' initial slope is $\pm 1/\tau$. If they continued at this initial slope they'd be done in one time constant.
- 3) In the first time constant the curve goes 63% from initial to the final condition.
- 4) After three time constants the curve is 95% of the way to the final condition.
- 5) By five time constants the curve is within 1% of the final condition and is usually considered finished. Mathematically, the curve approaches the final condition asymptotically and never reaches it. In reality, of course, this is nonsense. Whatever difference there may be between the mathematical solution and the final condition will soon be overshadowed by random fluctuations (called noise) in the real circuit.