

Imagine, if you will, a hydraulic device where the flow in a small pipe controls a valve in a larger pipe. The greater the flow in the small pipe the more it opens the valve in the large pipe. Take a look at the figure to the right. As an engineering student you should immediately see that this could be a useful device. One use might be as a flow-controlled on/off valve (switch). Or, depending on the flows and pressures involved, it could be used as an *amplifier*. That is, it could be used to make some hydraulic signal larger and more powerful. (A signal is a flow or pressure which conveys information and an amplifier is a device which increases the power of a signal.)

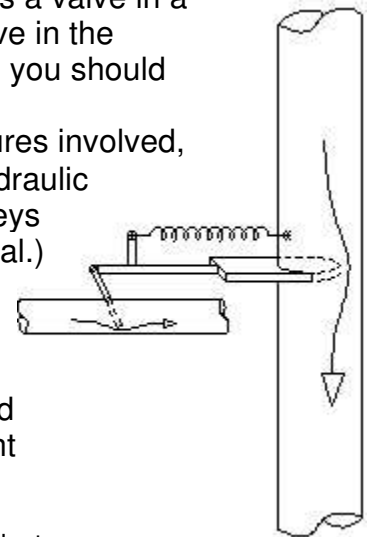

The electrical equivalent of this flow-controlled valve is a transistor. Specifically the NPN bipolar junction transistor (BJT). (There are other types.) The symbol for a transistor is shown below. Notice that it's a three-terminal device. That's because the control current (into the base) and the controlled current (into the collector) join together to form a single current out of the bottom (the emitter current). The valve drawn below is a more accurate analogy for the electrical transistor.

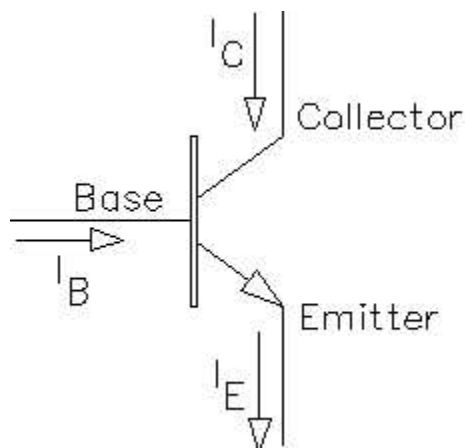

NPN transistor

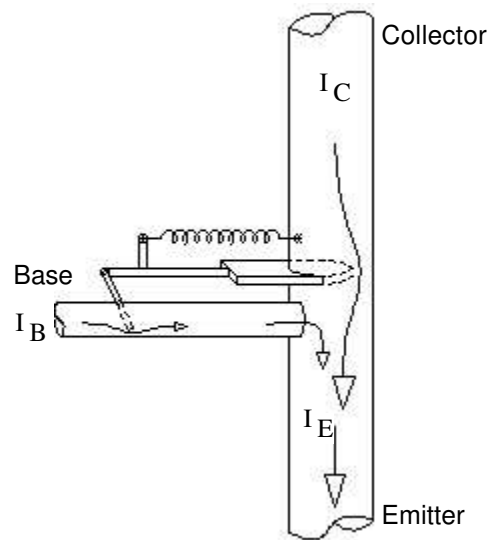

A transistor has three terminals-- the base, the collector, and the emitter. The current flow from the collector to the emitter (through the transistor) is controlled by the current flow from the base to the emitter. A small base current can control a much larger collector current. Often they are related by a simple factor, called beta (β). For a given base current, the transistor will allow β times as much collector current. The key word here is *allow*. The transistor doesn't make the current flow-- some outside power source does that. It simply regulates the current like the valve above. Big power transistors usually have a β s between 20 and 100. For little signal transistors, β is usually between 100 and 400. Darlington transistors (really two transistors in one package) can have β s in the 1000s.

A transistor can be used as a current controlled switch. When there's no base current, it's off, like an open switch. When there is a base current, it's on. If something outside of the transistor is limiting the collector current to less than β times the base current then the transistor will turn on as much as it can, like a closed switch. A transistor that is off is operating in its "cutoff" region. A transistor that is fully on is operating in its "saturation" region. A transistor that is partially on is in active control of its collector current (β times the base current) and is operating in its "active" region. (Note the valve analogy has a problem with the "open" and "closed" terms.)

There are many types of transistors. PNP transistors work like the NPN transistors, except that all the currents and voltages are backwards. Field-effect transistors (FETs) are controlled by voltage instead of current and come in many varieties. In this class we'll only work with NPN transistors.

Silicon diodes are made of two layers of doped silicon, a P layer is the anode and an N layer is the cathode. A P-N junction is a diode.

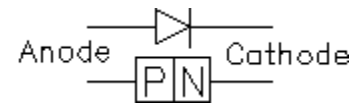

Bipolar junction transistors (BJTs) consist of three layers of doped silicon. The NPN transistor has a thin layer of P-doped silicon sandwiched between two layers of N-doped silicon. Each P-N junction can act like a diode. In fact, this is a fairly good way to check a transistor with an ohmmeter (set to the diode setting).

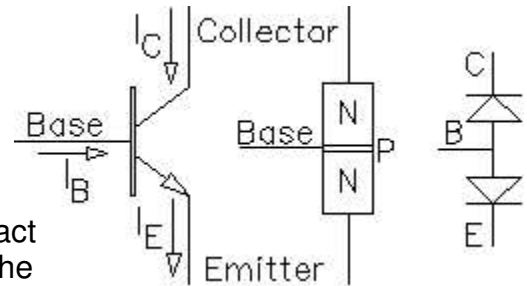

The base-emitter junction always acts like a diode, but because the base is very thin, it makes the other junction act like a controlled valve (you probably don't want to know the details, so call it magic).

Transistor Symbols

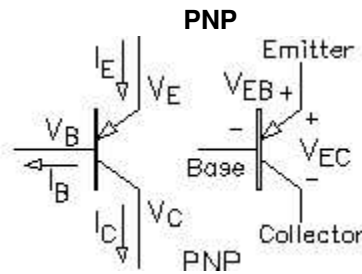
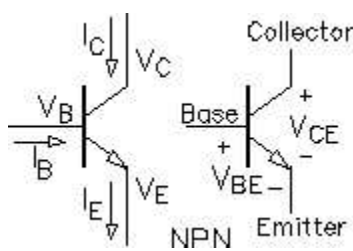

A bipolar junction transistor contains two diode junctions

		Cutoff	Active	Saturation
		reverse	reverse	forward
		reverse	forward	forward
		Junction bias		

Notice the subscripts

$$V_{BE} = V_B - V_E$$

$$V_{CE} = V_C - V_E$$

Replace v_{BE} with v_{EB} and

v_{CE} with v_{EC} in equations below

Modes or regions of operation

(v_{BE} and v_{CE} are approximate)

Cutoff (off)	Active (partially on)	Saturation (fully on)
$v_{BE} < 0.7V$	$v_{BE} \approx 0.7V$	$v_{BE} \approx 0.7V$
$i_B = 0$	$i_B > 0$	$i_B > 0$
	$v_{CE} \geq 0.2V$	$v_{CE} \approx 0.2V$
$i_C = 0$	$i_C = \beta i_B = \alpha i_E$ $\alpha \approx 1$ controlled by the transistor	$i_C < \beta i_B$ limited by something outside of the transistor

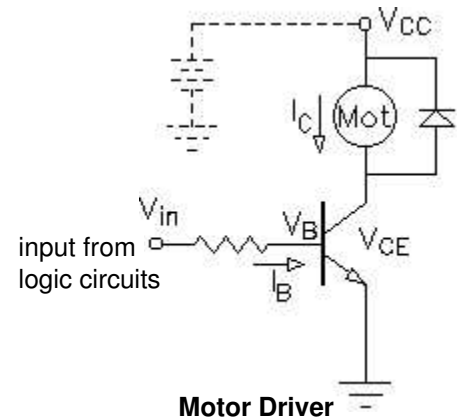

The Transistor as a switch

One of the most common uses of a transistor is as a current-controlled switch. Transistor switches are the basis for all digital circuits, but that's probably not where you'll use the transistor. More likely, you'll want to control a high-current device, like a motor, with an integrated-circuit output from a computer or logic circuit. The small integrated circuit won't be able to supply enough current to run the motor, so you'll use a transistor to switch the larger current that flows through the motor. The input is hooked to the base of the transistor. (Often through a current limiting resistor, since V_B will only be 0.7V when the transistor is on.) A small I_B can switch on the much larger I_C and V_{CE} can be as low as 0.2V.

V_{CC} : The terminal marked V_{CC} above is just a circuit terminal hooked to a power supply, drawn in dotted lines here, but usually not shown at all. Power supply wires, like ground wires are often not shown explicitly on schematics. It makes the schematics a little less cluttered and easier to read.

Diode: If you're switching an inductive load, like a motor, you should add a diode so that you're not trying to switch off the motor current instantly. The diode (called a *flyback* diode when used like this) provides a path for the current still flowing through the motor when the transistor is switched off.

H-bridge: Of course, if you want to make the motor turn in both directions you'll need a more complex circuit. Look at the circuit at right, it's has the shape of an H, hence the name. If transistors Q_1 and Q_4 are on, then the current flows as shown, left-to-right through the motor. If transistors Q_2 and Q_3 are on, then the current flows the other way through the motor and the motor will turn in the opposite direction. (The motor here is a permanent-magnet DC motor.) In my circuit, the top two transistors are PNPs, which makes the circuit more efficient. The H-bridge could also be made with all NPNs or with power MOSFET transistors.

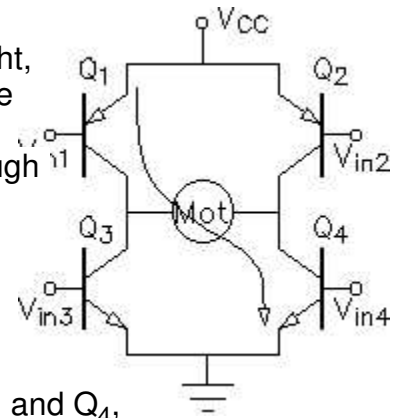

An H-bridge requires four inputs, all operated in concert. To turn on Q_1 and Q_4 , as shown, V_{in1} would have to be low and V_{in4} would have to be high. At the same time, the other two transistors would have to be off, so V_{in2} would have to be high and V_{in3} would have to be low.

If the control circuit makes a mistake and turns on Q_1 and Q_3 (or Q_2 and Q_4) at the same time you'll have a toaster instead of a motor driver, at least for a short while.

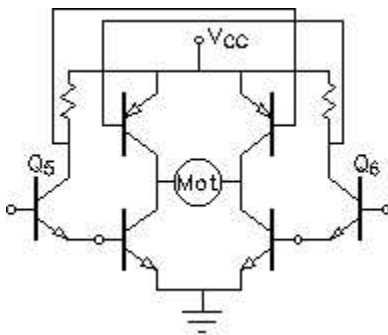

The circuit at left requires only two inputs. Transistors Q_5 and Q_6 work as *inverters*, when their inputs are high, their outputs are low and vice-versa. The resistors are known as *pull-up* resistors.

The H-bridge should also include flyback diodes.

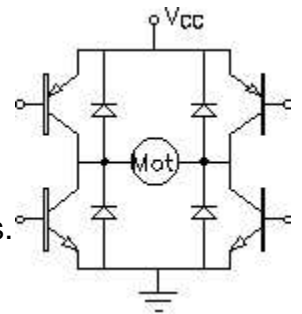

Linear Amplifiers

The objective of a linear amplifier is to output a faithful reproduction of an input signal, only bigger. A voltage amplifier makes the signal voltage bigger. A current amplifier makes the signal current bigger. Many amplifiers do both. All amplifiers should make the signal power bigger (depends somewhat on the load). Of course that means that they need a source of power, generally DC power from a battery or power supply. The signals are usually AC.

Unlike transistor switches, which operate in cutoff and saturation, linear amplifiers must operate in the active region.

Important relations: (active region)

$$v_{BE} = v_B - v_E = 0.7 \cdot V \quad v_{CE} = v_C - v_E > 0.7 \cdot V (\approx 0.2V \text{ if saturated})$$

$$i_C = \beta \cdot i_B \quad i_C = \alpha \cdot i_E \approx i_E$$

Bias:

Outside of the active region the input (base current) doesn't linearly control the output (collector current). To work as an linear amplifier, a transistor must operate in the active region. That means that the transistor must be turned on part way even when there's no signal at all. Look back at the valve analogy, if small fluctuations in the horizontal pipe flow (i_B) should produce larger but similar fluctuations in the vertical pipe flow (i_C), then there must always be *some* flow. If either flow ever stops, the horizontal pipe flow (i_B) is no longer in control.

To work in the active region i_B and i_C must be positive for all values of the AC signals. i_B and i_C must be *biased* to some positive DC value. We use capital letters (I_B and I_C) for these DC bias values and lower case letters (i_b and i_c) for the AC signals that will appear as fluctuations of these DC values

All voltages and currents can be shown in three different ways

	examples	meaning
CAP _{CAP}	V_B I_C	DC, Bias
sm _{sm}	v_b i_c	AC, signal
sm _{CAP}	v_B i_C	DC and AC Together

The objective of bias then, is to partially turn on the transistor, to turn it, sort-of, half-way on. Now if I twiddle I_B , I_C will show a similar, but bigger, twiddle-- that' s the whole idea. The transistor should never go into cutoff for any expected input signal, otherwise you' ll *geclipping* at the output. Clipping is a form of distortion, where the output no longer looks like the input.

Furthermore, the transistor must not saturate. That will also cause clipping at the output.

Because β can vary widely from transistor to transistor of the same part number and V_{BE} changes with temperature, achieving a stable bias can be a bit of a problem. Usually an emitter resistor (R_E) is needed to stabilize the bias.

DC Analysis in the active region

DC analysis applies to both switching and bias, although the circuits we' ll look at here will include an R_E and we' ll be working in the active region, meaning they are bias circuits. The key to DC analysis with an R_E is usually finding V_B .

The circuit at right shows a typical bias arrangement. The equations below are for that circuit, adapt them as necessary to fit your actual circuit.

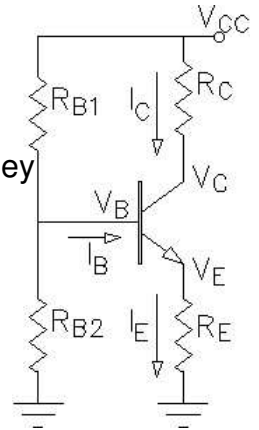

If you can neglect I_B :

Often in quick-and-dirty analysis you can neglect the base current, I_B . In that case:

$$V_B = V_{CC} \cdot \frac{R_{B2}}{R_{B1} + R_{B2}} \quad V_E = V_B - 0.7 \cdot V \quad I_E = \frac{V_E}{R_E} \approx I_C \quad V_C = V_{CC} - I_C \cdot R_C$$

This assumption is OK if: $R_{B1} \parallel R_{B2} \ll \beta \cdot R_E$

Quick check: $R_{B1} < 10 \cdot R_E$ and/or $R_{B2} < 10 \cdot R_E$ Should result in <10% error if $\beta = 100$

If you can't neglect I_B :

Then you need to make a Thevenin equivalent of the base bias resistors.

$$V_{BB} = V_{CC} \cdot \frac{R_{B2}}{R_{B1} + R_{B2}} \quad R_{BB} = \frac{1}{\frac{1}{R_{B1}} + \frac{1}{R_{B2}}}$$

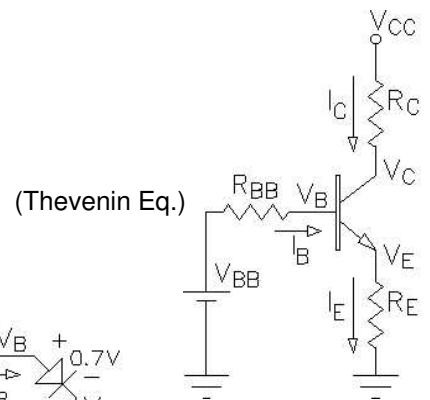

From the base' s point-of-view, the emitter resistor will look $\beta + 1$) times bigger than it really is. This is because $(\beta + 1)$ times as much current flows through R_E than into the base. We can ignore the fact that the current is bigger if we pretend that the resistor is bigger. That leads to the simplified circuit. (Usually we use β as the factor rather than $(\beta + 1)$, after all β just isn' t that well known anyway.)

$$I_B = \frac{V_{BB} - 0.7 \cdot V}{R_{BB} + \beta \cdot R_E} \quad I_C = \beta \cdot I_B \approx I_E \quad V_E = I_E \cdot R_E \approx I_C \cdot R_E \quad V_B = V_E + 0.7 \cdot V$$

$$V_C = V_{CC} - I_C \cdot R_C$$

OR: $V_B = I_B \cdot \beta \cdot R_E + 0.7 \cdot V \quad V_E = V_B - 0.7 \cdot V \quad I_E = \frac{V_E}{R_E} \approx I_C \quad V_C = V_{CC} - I_C \cdot R_C$

Examples, DC (Bias) Analysis

1)

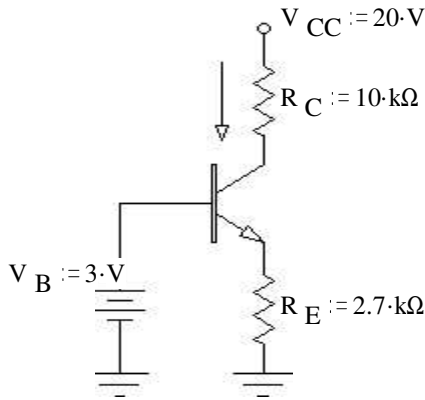

Given:

$$V_B := 3 \cdot V, \text{ regardless of current into base}$$

$$V_{CC} := 20 \cdot V \quad R_C := 10 \cdot k\Omega \quad R_E := 2.7 \cdot k\Omega$$

Find I_C , V_C , V_{CE} , and P_Q :

Solution:

$$V_E := V_B - 0.7 \cdot V \quad V_E = 2.3 \cdot V$$

$$I_E := \frac{V_E}{R_E} \quad I_E = 0.852 \cdot \text{mA} \approx I_C := I_E$$

$$V_C := V_{CC} - I_C \cdot R_C \quad V_C = 11.48 \cdot V$$

$$V_{CE} := V_C - V_E \quad V_{CE} = 9.18 \cdot V > 0.2V, \text{ OK, is in active region}$$

$$P_Q := V_{CE} \cdot I_C \quad P_Q = 7.82 \cdot \text{mW}$$

2)

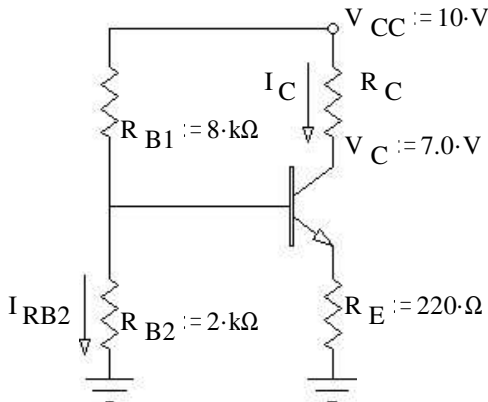

Given: may neglect I_B

$$V_{CC} := 10 \cdot V \quad V_C := 7.0 \cdot V \quad R_{B1} := 8 \cdot k\Omega \quad R_{B2} := 2 \cdot k\Omega \quad R_E := 220 \cdot \Omega$$

Find V_B , V_E , I_C , R_C , V_{CE} , I_{RB2} , and P_Q :

Solution:

$$V_B := V_{CC} \cdot \frac{R_{B2}}{R_{B1} + R_{B2}} \quad V_B = 2 \cdot V$$

$$V_E := V_B - 0.7 \cdot V \quad V_E = 1.3 \cdot V$$

$$I_E := \frac{V_E}{R_E} \quad I_E = 5.91 \cdot \text{mA} \approx I_C := I_E$$

$$R_C := \frac{V_{CC} - V_C}{I_C} \quad R_C = 508 \cdot \Omega$$

$$V_{CE} := V_C - V_E \quad V_{CE} = 5.7 \cdot V > 0.2V, \text{ OK, is in active region}$$

$$I_{RB2} := \frac{V_B}{R_{B2}} \quad I_{RB2} = 1 \cdot \text{mA}$$

$$P_Q := V_{CE} \cdot I_C \quad P_Q = 33.68 \cdot \text{mW}$$

3)

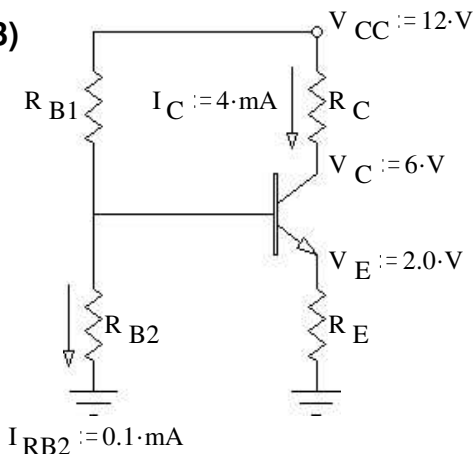

Given: may NOT neglect I_B $\beta := 150$

$$V_{CC} := 12 \cdot V \quad V_E := 2.0 \cdot V \quad V_C := 6 \cdot V \quad I_{RB2} := 0.1 \cdot \text{mA} \quad I_C := 4 \cdot \text{mA}$$

Find R_E , R_C , V_B , I_B , R_{B2} , and R_{B1} :

Solution:

$$V_{CE} := V_C - V_E \quad V_{CE} = 4 \cdot V > 0.2V, \text{ is in active region}$$

$$I_E \approx I_C \quad I_E := I_C \quad R_E := \frac{V_E}{I_E} \quad R_E = 500 \cdot \Omega$$

$$R_C := \frac{V_{CC} - V_C}{I_C} \quad R_C = 1.5 \cdot k\Omega$$

$$V_B := V_E + 0.7 \cdot V \quad V_B = 2.7 \cdot V \quad I_B := \frac{I_C}{\beta} \quad I_B = 0.027 \cdot \text{mA}$$

$$R_{B2} := \frac{V_B}{I_{RB2}} \quad R_{B2} = 27 \cdot k\Omega \quad R_{B1} := \frac{V_{CC} - V_B}{I_{RB2} + I_B} \quad R_{B1} = 73.4 \cdot k\Omega$$

AC Analysis of Common emitter (CE) amplifier

With an R_E , any AC signal applied to the base will then also appear just as big at the emitter (just lower by 0.7V DC). The AC signal current through R_E , will be about the same as through R_C , so the AC signal voltage across R_C will be bigger than that across R_E by the ratio of R_C/R_E . Recalling that the signal at the emitter is about the same as the signal at the base...

$$\text{base to collector AC gain} = \frac{v_c}{v_b} = \frac{R_C}{R_E}$$

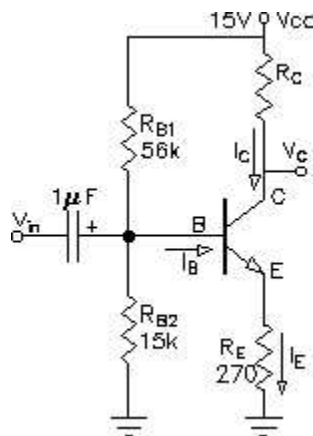

Signals

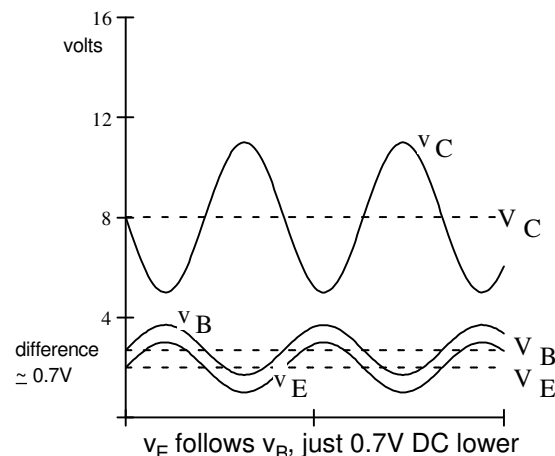

If a capacitor is placed in parallel with R_E then the effective AC resistance in the emitter goes way down and the gain goes way up. In that case we need a way to estimate the AC resistance within the base-emitter junction itself.

This is called the small-signal emitter resistance:
$$r_e = \frac{25\text{-mV}}{I_C}$$

To find the gains when the input has a source resistance and the output is connected to a load resistor, the calculations become a little more complex. **YOU DON' T NEED TO KNOW THE FOLLOWING MATERIAL.**

R_E is the DC resistance from emitter to ground

r_e is the AC signal resistance from emitter to ground, may be zero

Input impedance: $R_i = R_{B1} \parallel R_{B2} \parallel \beta \cdot (r_e + R_e)$

Output impedance: $R_o = R_C \parallel r_o$ ← r_o Often neglected

AC collector resistance: $r_c = R_C \parallel R_L \parallel r_o$

r_o is a characteristic of the transistor, and is often neglected

Voltage gain: $A_v = \frac{v_o}{v_b} = \frac{r_c}{r_e + R_e}$

OR:
$$\frac{v_o}{v_s} = \frac{R_i}{R_s + R_i} \cdot \frac{r_c}{r_e + R_e}$$

Current gain:
$$A_i = \frac{i_o}{i_i} = \frac{r_c}{r_e + R_e} \cdot \frac{R_i}{R_L} = A_v \cdot \frac{R_i}{R_L}$$

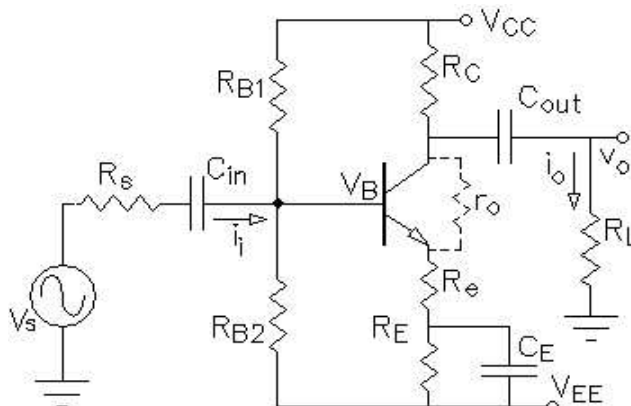

There are several other types of transistor amplifiers, but we won' t look at them here.

AC Signal Example

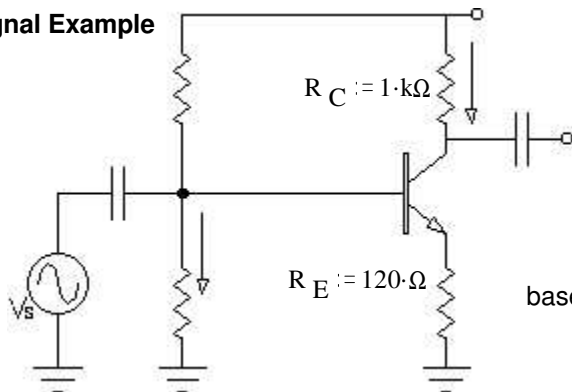

If the v_s signal were applied at the base, an AC signal would also appear at the collector. How much larger would it be? (Voltage gain).

base to collector AC gain =
$$\frac{v_c}{v_b} = \frac{R_C}{R_E} = 8.33 \quad \text{times bigger}$$