

ME EN 3200/3210 MECHATRONICS I/II  
FINAL COMPETITION, FALL 2008  
*INDIANA JONES AND THE SECRET WAREHOUSE*

**General project description:** Design and build an autonomous robot to compete in the 2009 Mechanical Engineering *Indiana Jones and the Secret Warehouse* Competition on *Design Day* in April 2009. During the Fall semester, the objective is to design and build a robot that moves under control of the Handyboard. At the end of the Fall semester, the robot will need to demonstrate working mechanisms to drive in a straight line, to make turns, and to pick up a crate from a shelf (see shelf and crate schematics at end of this document).

During the Spring semester, the objective will be to complete the robot by incorporating additional sensors, control systems, and offensive/defense strategies.

**Teams:** Four students per team; teams will be set during the first week of lab. Kyle Simmons <kyle.simmons@utah.edu> of the Center for Engineering Leadership can be contacted to discuss team issues that arise during the course of the semester.

**Final Competition overview:** In the final competition, your robots will search through the secret warehouse for the three crates containing the hidden archeological artifacts from the Indiana Jones movies. You will be competing against a robot starting at the opposite end of the warehouse. Points will be accumulated by each robot for collecting the crates with the artifacts and depositing them at the start areas. The team whose robot has collected the most points by the end of 120 seconds wins the matchup.

**Fall Semester Grading:** Your grade for the project will be based on your group's progress throughout the semester and by your group's final presentation, with the following breakdown:

Memos	40%	Presentation	20%
Robot	40%		

Note that your grade may not necessarily be exactly the same as all the other students in your group; (optional) team evaluations will be provided at the end of the semester.

**Provided Materials:** You are responsible for any and all damages: many of these electronic components are sensitive to electrostatic discharge and care must be taken to ground yourself before handling them. These materials will be provided in lab the week of Oct. 6 (you may inspect these items during earlier lab sessions). You will also receive a toolbox with additional supplies that must be returned at the end of the spring semester.

1. One Handyboard controller: Motorola 68HC11 microprocessor, 4 DC motor outputs, 7 analog inputs, 9 digital inputs.
2. One Expansion board for the Handyboard, with 10 analog inputs, 9 digital outputs, 6 servo motor controls.
3. 7.2 V battery.
4. Basic electronic components: resistors, capacitors, op-amps, wire, infrared emitters, infrared detectors, etc.
5. Scrap mechanical stock in machine shop.

**Budget:** Each team has a \$200 budget per semester, which is derived from the course fees. You may use your budget to purchase parts and materials from local suppliers and internet vendors, etc., or as credit towards the use of parts and materials that are stocked in the mechatronics lab. A price sheet for stocked parts and materials will be made available on webCT. Each team may also use an extra \$20 per semester out of pocket or by counting the value of donated parts and materials. In the fall, you may elect to borrow against your spring budget, but you will have to wait until after the start of the spring semester to get reimbursed. Your lab TA must approve all purchases/credits/donations.

ME EN 3200/3210 MECHATRONICS I/II  
FINAL COMPETITION, FALL 2008  
*INDIANA JONES AND THE SECRET WAREHOUSE*

**Resources:**

1. *Motors:* There are a limited supply of used DC motors & gearboxes and RC servo motors in the mechatronics lab. You may spend your budget as credits towards these motors, or on other motors (or actuators) of your own choice, provided those motors could be procured by other students. If in doubt, ask the Mechatronics Supreme Court (see below). Donated motors must be included in your financial summary, and count towards the \$20 out-of-pocket limit. A recommended list of motors and their respective suppliers will be published on webCT.
2. *Sensors:* A list of recommended sensors (ultrasonic, infrared, magnetic) and their respective suppliers will be published on webCT.
3. *Mechatronics Lab:* wiring, electrical components, some fasteners (free within reason). We will also purchase a variety of metal and plastic stock material. You may spend your budget on credits towards pieces of these materials.
4. *Student Machine Shop:* materials, tools, machinery. You may also spend your budget to have parts machined with the waterjet by the machine shop staff (cost of this service TBA).
5. *Local stores and Internet Vendors:* A list of recommended local stores and internet vendors for various mechanical and electrical parts and materials will be published on webCT.

**Competition rules:**

1. *Contest Course:* The warehouse is a symmetric wooden platform surrounded by a wall, as shown in the dimensioned drawings at the end of this document. Inside the warehouse are three shelves with aisles between and around. Each shelf holds four crates, with room to grab each crate from the sides or lift from underneath. There are two start areas on either side of the warehouse. Black lines will be marked down the center of each aisle and start area. There will be a net around the outside of the walls of each start area.
2. *Objective:* Your robot must navigate through the warehouse, using sensors to follow the lines and detect the walls, shelves, and crates. Three of the twelve crates will have the prized artifacts hidden inside, and will be randomly relocated for each match. The artifacts will be visible to the audience, but will require special sensing by the robots to locate them. The crate with the *Crystal Skull* will emit a magnetic field, while the crates with the *Ark* and the *Grail* will have light-emitting-diodes facing the aisles. The crates will each weigh no more than one pound. Your robot must use a mechanism to load the prize crates onto your robot and deposit them in the net at either start area. Points will be awarded as follows:

- Collect crate with the *Crystal Skull* = 5 points
- Collect crate with the *Ark of the Covenant* = 3 points
- Collect crate with the *Holy Grail* = 3 points
- Bonus for each prize deposited in net outside of either starting area = 3 points

The objective is to collect the most points by the end of 120 seconds without violating the robot rules. *Note:* a crate counts as “collected” if it is successfully loaded onto your robot and is either deposited in one of the nets or is still remaining on your robot when time runs out.

3. *Competition structure:* Your robot will compete twice in pool play. The top sixteen scoring teams from pool play will advance directly into a “Sweet Sixteen” bracket. The teams in the “Sweet Sixteen” bracket will compete in single-elimination to determine the winner. In each single-elimination match, the team with the highest score will advance to the next round. If neither team scores, neither team will advance. In the case of a tie (other than 0-0), the crates will be randomly rearranged and the match will be replayed. A violation of any of the robot rules (see below) will result in disqualification from the match (and possibly the competition).
4. *Grand Prize:* Students on the team that wins the competition will have the option to skip the final exam *if* they have better than average scores on the exams and homework assignments.

ME EN 3200/3210 MECHATRONICS I/II  
FINAL COMPETITION, FALL 2008  
*INDIANA JONES AND THE SECRET WAREHOUSE*

**Robot rules:**

1. *Locomotion:* Any method of moving your robot is allowed; spiked wheels (or other surfaces damaging to the course) are expressly forbidden.
2. *Size:* The robot must fit within a 25 cm x 25 cm x 25 cm cube (sizing boxes are provided in lab); it will be sized the day of the contest. The robot may not expand beyond this size until the starting beacon indicates that the contest round has begun (e.g. any graspers or end-effectors must be retracted).
3. *Weight:* The robot may not exceed 3kg; it will be weighed the day of the contest.
4. *Power source:* All robots must use the provided (single) rechargeable battery pack and Handyboard battery only. No other energy sources are permitted.
5. *Exterior Skin:* A protective outer skin is required for the competition in the spring. It must protect all interior components as well as convey the theme of the robot. It must be removable and well secured. Holes in the skin are permissible for sensors, grasping devices, access to the controller, etc., and may provide structural support for the robot.
6. *Appearance:* High quality craftsmanship and finishing is expected. Wires must be neatly harnessed, circuits well organized, and the exterior skin visually appealing. A skin that conveys the robot theme as well as showing some interior features is encouraged. The appearance will be a factor in both fall and spring robot grades.
7. *Autonomy:* The robots will initially be placed on one of the two home base areas. Each team will power on their robot, and the match will be *started* when beacons at the centers of the home bases are simultaneously turned on. The robots must then compete without user intervention. The robots must stop automatically after 120 seconds have elapsed.
8. *Manufacturing:* Each group must design and build all functional components of their robot. This includes and is not limited to the mechanisms, support frame, etc.
9. *Allowed Purchased Components:* Fasteners, bushings, bearings, raw material (bar stock, threaded rods, straight rods), motors/actuators (as detailed above, under Resources), gears, pulleys, springs, cables, belts, chains, wheels, or tracks are acceptable. If in doubt, ask the Mechatronics Supreme Court (see below).
10. *Budget:* Net expenditures must not exceed \$220 per semester, and must be proven via a cost analysis included in the presentation. Your lab TA must approve all expenditures.
11. *Robot-to-robot conduct:* Robots may block each other and come into incidental contact, but may **not** push, grab, lift, flip, knock over, or inflict damage on each other. Hitting, kicking, striking, burning, melting (heat or chemicals), sensory interference of any kind (e.g. distracting light or magnetic sources/shields), and the use of projectiles are **not** allowed. Discarding (which includes dropping, launching, ejecting, or losing) any pieces, parts, components, liquids, gasses, or solid matter is also forbidden. Bottom line: you should compete with your opponent, but you should **not** attempt to disable or destroy them. In addition, damaging or anchoring to the contest table (e.g. no spikes, cleats, suction cups, or anchors) is prohibited.
12. *Interference and Supervision:* Team members may not interfere with the contest table or robots. Once the match has started, only the supervising TAs may approach the course. If a crate becomes misaligned or knocked onto the floor of the course, the TAs will be authorized to replace/realign it on the shelf. If a robot engages in unallowable behavior, the TAs will be authorized to return it to the start position or remove it from the course.

**Rule clarification and amendment:**

These rules may be modified for clarity or to preserve the "spirit" of the contest. If you have questions, e-mail Dr. Mascaro at [smascaro@mech.utah.edu](mailto:smascaro@mech.utah.edu) with "Mechatronics Supreme Court" in the subject line. Any clarifications or changes will be discussed and decided upon on Friday mornings by the Mechatronics Supreme Court (Dr. Mascaro and the lab TAs), described in class, and detailed on webCT/Project.

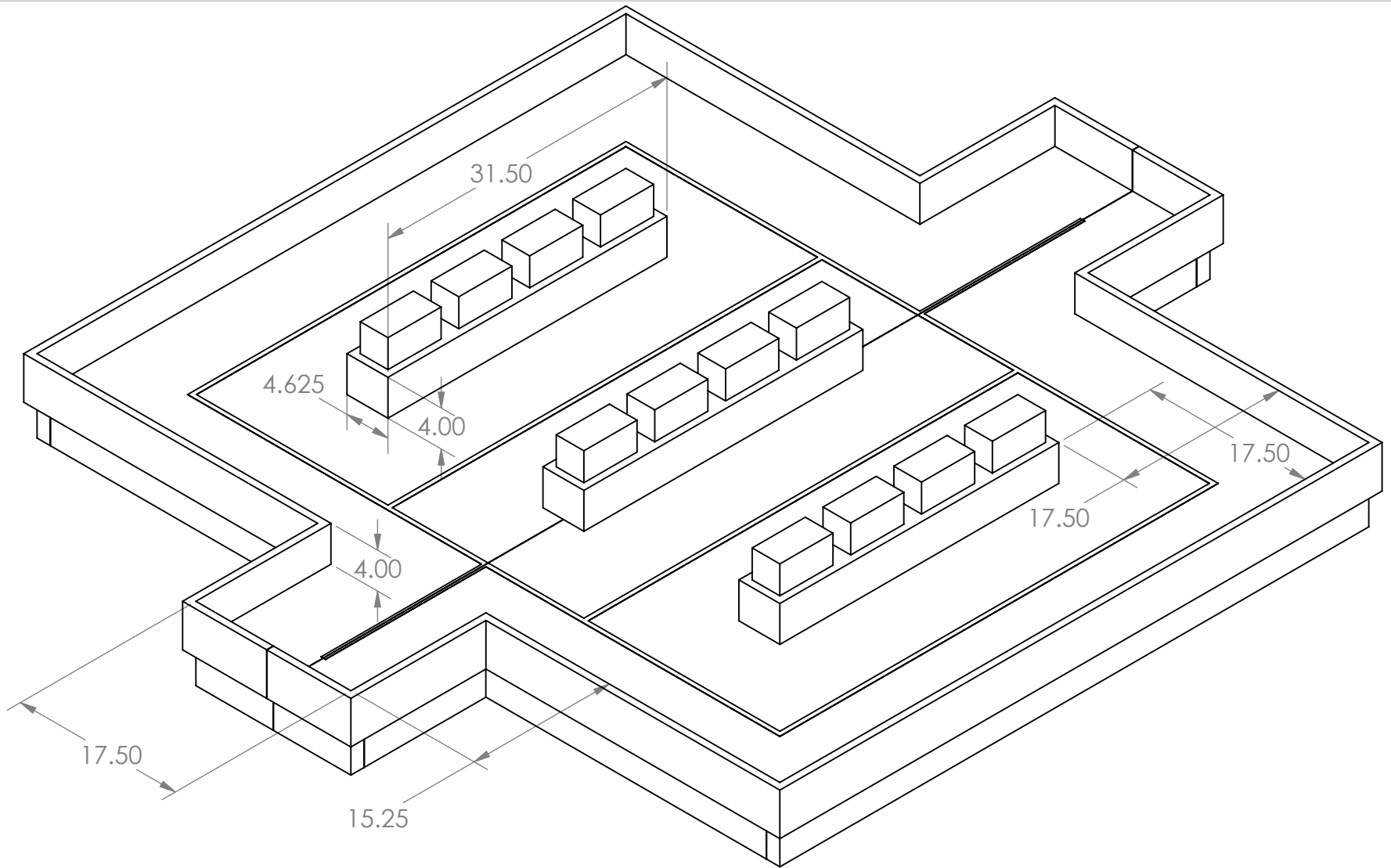

	NAME	DATE		
DRAWN	QC	9/2/2008	ME EN 3200 MECHATRONICS CLASS COMPETITION COURSE	
CHECKED			INDIANA JONES AND THE SECRET WAREHOUSE	
ENG APPR.				
MFG APPR.				
Q.A.				
COMMENTS: ALL UNITS IN INCHES			SIZE	DWG. NO.
			<b>A</b>	<b>Warehouse</b>
			SCALE: 1: 12	WEIGHT:
			REV <b>1</b>	
			SHEET 1 OF 4	

**PROPRIETARY AND CONFIDENTIAL**

THE INFORMATION CONTAINED IN THIS DRAWING IS THE SOLE PROPERTY OF THE UNIVERSITY OF UTAH DEPARTMENT OF MECHANICAL ENGINEERING. ANY REPRODUCTION IN PART OR AS A WHOLE WITHOUT THE WRITTEN PERMISSION IS PROHIBITED.



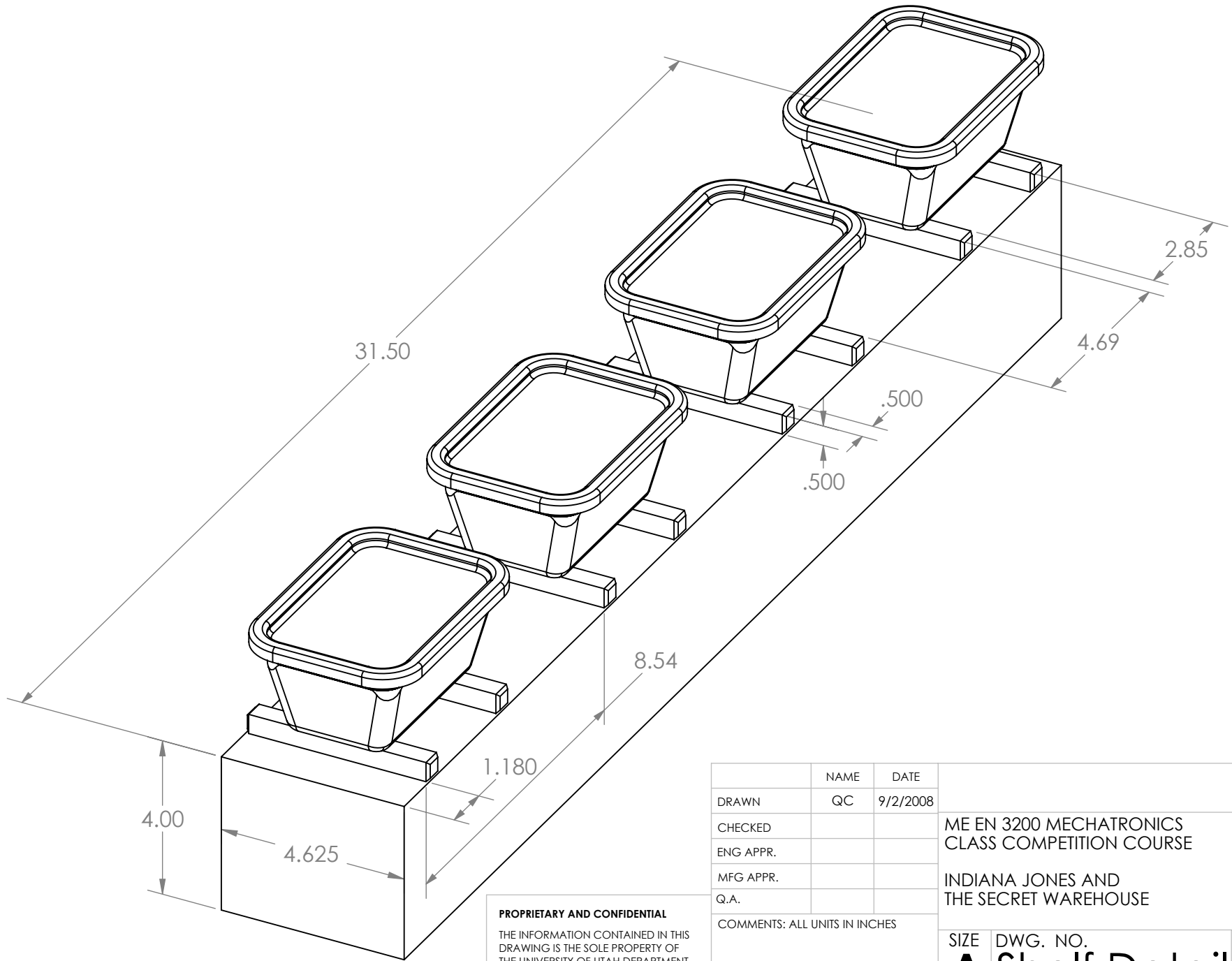

**PROPRIETARY AND CONFIDENTIAL**

THE INFORMATION CONTAINED IN THIS DRAWING IS THE SOLE PROPERTY OF THE UNIVERSITY OF UTAH DEPARTMENT OF MECHANICAL ENGINEERING. ANY REPRODUCTION IN PART OR AS A WHOLE WITHOUT THE WRITTEN PERMISSION IS PROHIBITED.

	NAME	DATE
DRAWN	QC	9/2/2008
CHECKED		
ENG APPR.		
MFG APPR.		
Q.A.		

COMMENTS: ALL UNITS IN INCHES

ME EN 3200 MECHATRONICS  
CLASS COMPETITION COURSE

INDIANA JONES AND  
THE SECRET WAREHOUSE

SIZE	DWG. NO.	REV
	<b>A Shelf Detail</b>	<b>1</b>

SCALE: 1:3	WEIGHT:	SHEET 3 OF 4
------------	---------	--------------

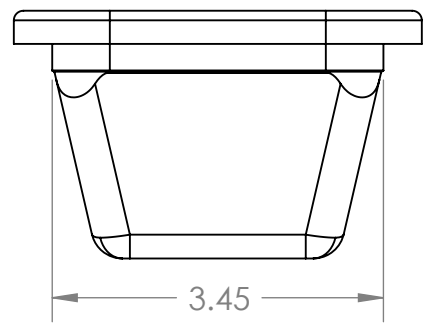
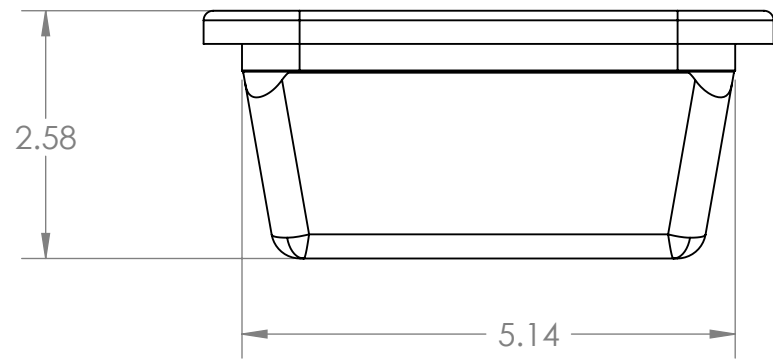
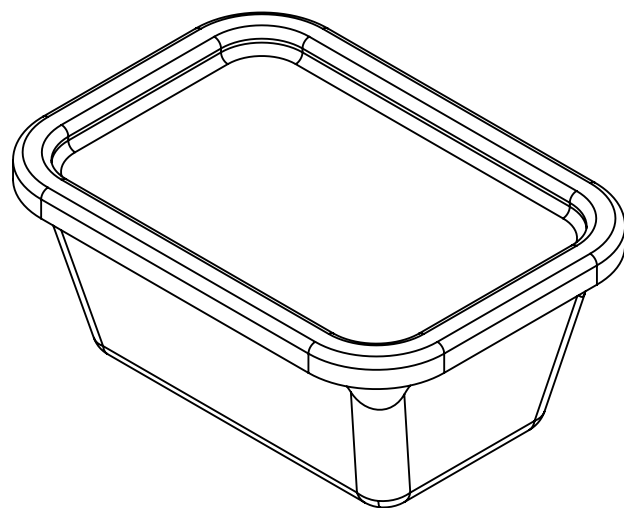
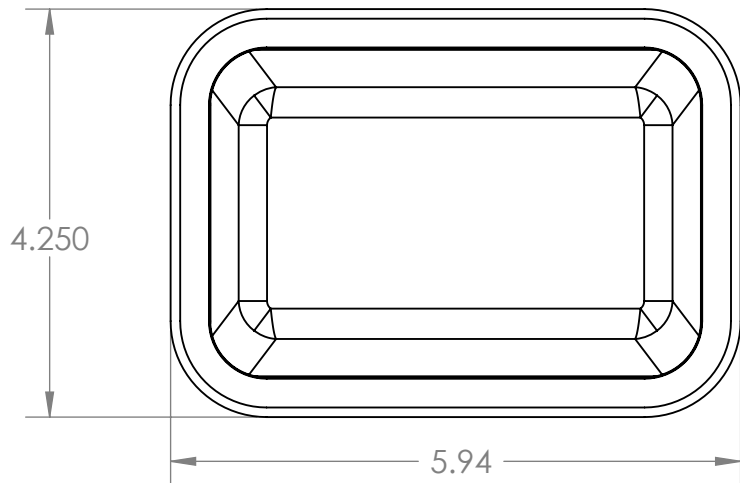

**PROPRIETARY AND CONFIDENTIAL**  
 THE INFORMATION CONTAINED IN THIS DRAWING IS THE SOLE PROPERTY OF THE UNIVERSITY OF UTAH DEPARTMENT OF MECHANICAL ENGINEERING. ANY REPRODUCTION IN PART OR AS A WHOLE WITHOUT THE WRITTEN PERMISSION IS PROHIBITED.

	NAME	DATE		
DRAWN	QC	9/2/2008		
CHECKED			ME EN 3200 MECHATRONICS CLASS COMPETITION COURSE	
ENG APPR.				
MFG APPR.			INDIANA JONES AND THE SECRET WAREHOUSE	
Q.A.				
COMMENTS: ALL UNITS IN INCHES			SIZE	DWG. NO.
			<b>A</b>	<b>CRATE</b>
			SCALE: 1:1	REV 1
			WEIGHT:	SHEET 4 OF 4