

University of Utah
Electrical & Computer Engineering Department
 ECE 2210
Operational Amplifiers

A. Stolp, 11/28/01
 rev, 11/28/12

Note: Bring the Op-amp handout from class and the servo schematic from lab 11. Bring the Control Systems lab handout (Lab 9) if you don't remember how to measure the voltage gains of the servo and you didn't document it well enough in your lab notebook.

Objective

To explore some of the more common uses of operational amplifiers, also known as op-amps.

Parts:

- Resistors of your choice in the 100 Ω to 1 MΩ range.
- two 0.1 to 0.22 μF (224) capacitors
- two 47 μF to 100 μF capacitors
- **LM324 or TL084 (better) quad operational amplifier**
- Breadboard and wires

Equipment and materials from stockroom:

- Servo

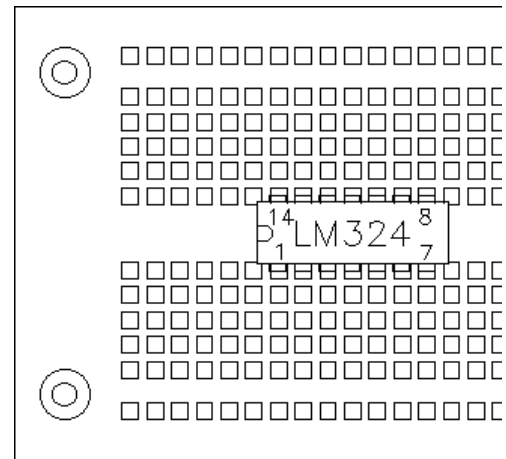

Experiment

Plug the LM324 IC (Integrated Circuit) into the breadboard so that it spans the little center ditch. The notch and/or white band should be on the left and the writing on the IC should be right-side-up. The leads of the IC are numbered around in a CCW direction, starting in at the lower-left corner.

The op-amps inside the LM324 are shown at right. This one IC contains four complete op-amps. All are powered by the same two power input terminals, V+ and V-. To get both +15 and -15 V from the power supply, first push and hold the “Track” button for at least 1 second. Then push the “+25V” button and adjust the voltage to 15V. With tracking turned on the “-” output will “track” the “+” output and automatically be set to -15V. Hook up +15 V to the V+ pin of the IC and -15 V to the V- pin. Look carefully at the drawing, don't hook the power up backwards-- it's easy to do because the V- pin is on top (which is counter-intuitive). The V- and V+ connections are power connections. DO NOT confuse them with the signal inputs to the op-amps (labeled - and +).

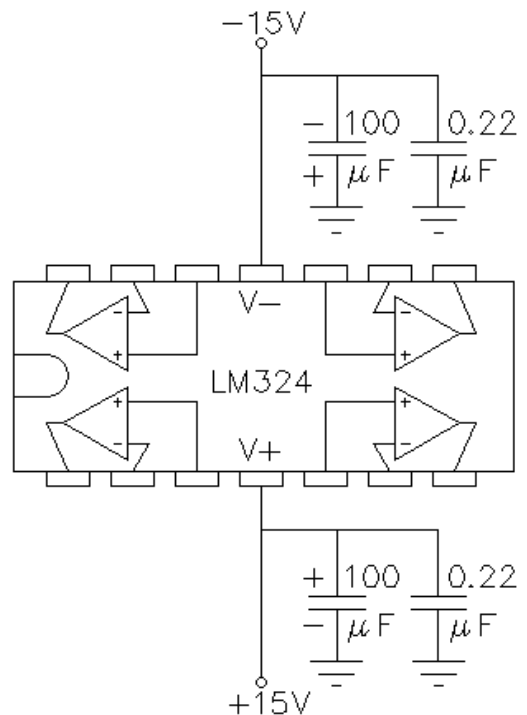

Most op-amp circuits won't work right unless the op-amp is powered with both + and - power supplies. This can be inconvenient, but using op-amps with single-sided supplies is tricky. REMEMBER this! One common mistake people make with op-amps is trying to use them with a single power supply.

The power supply's ground will be the ground for all your circuits and should be hooked to the breadboard somewhere, but is not hooked up to the op-amp directly.

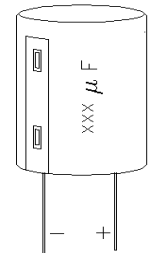

Finally, some capacitors are a good idea. They suppress noise and oscillation problems that can cause you headaches later. The values are not critical, and you can often get by without using them at all, but I do recommend hooking some up as shown. Don't connect the electrolytic capacitors backwards! Remember that they have + and - leads.

Voltage follower

Find the voltage follower circuit in the Operational Amplifiers handout. Choose one of the four op-amps in the LM324 and build a voltage follower. (That constitutes one wire hooked from the output to the - input.) Hook the signal generator in the bench up to the + input of the same op-amp. Hook the CH1 of the scope up to the output and hook CH2 to the input. Hook all grounds together. Set up the signal generator to produce a sine wave at about 1 kHz and observe the op-amp output with the scope. Adjust the signal generator if necessary so you see a good output. Observe the input signal and determine if the input and output are the same (Make sure that the "cal" knobs on the scope are all in the full CW position). Draw the circuit in your notebook and record the measurements which confirm that this circuit works as expected.

If it doesn't work...

1. Use a voltmeter to check the voltages at the power pins.
2. Check other connections, especially ground.
3. Try another op-amp within the LM324.
4. Have your circuit checked by the TA and if it's OK, replace the IC with another. ICs can be damaged, especially if the power is hooked up backwards.

Noninverting Amplifier

Find the noninverting amplifier in the Operational Amplifiers handout. Design and build an amplifier with a voltage gain of about 11. Use resistors of your choice, but use values in the 100 Ω to 1 MΩ range (I suggest $R_1 = 10 \text{ k}\Omega$ and $R_f = 100 \text{ k}\Omega$). Test this circuit like you did the voltage follower, only now you're looking for the amplitude of the output voltage to be 11 times bigger than the amplitude of the input. If the output waveform shows clipping, turn down the amplitude of the input signal. Draw the circuit in your notebook (with the parts values that you used) and record the measurements which confirm that this circuit works as expected.

$$V_a \approx V_b$$

Move the CH1 scope channel from the op-amp's output to its - input. Now CH2 should be hooked to the + input and CH1 to the - input. Confirm that these two signals are practically the same, as expected. Return CH1 to the output.

Clipping

Turn up the amplitude of the input signal until the output waveform shows clipping both top and bottom. This is a non-linearity of the amplifier. Sketch the clipped waveform in your notebook. Use the scope to measure the maximum positive and maximum negative voltages available from the op-amp (the clipping levels, also called the “rail” voltages). Look at the two op-amp inputs like you did in the previous paragraph. Notice that the two inputs are not the same anymore and that whenever they are noticeably different, the output is at either its positive or negative limit. Sketch these two waveforms (the two op-amp inputs inputs) in your notebook. Return the scope connection to the output and turn down the amplitude of the input signal so the output is about 20 Vpp.

Slew

Turn up the frequency of the input signal until the output looks like a triangle wave instead of a sine wave (It will be a little smaller too). What you’re seeing is the maximum rates (up and down) at which the op-amp is able to change its output voltage. In this case it isn’t fast enough to keep up with the sine wave. Sketch the slewing waveform in your notebook. If you turn down the amplitude of the input signal you can make the output look like a sine wave again. Why? Turn the frequency back down to around 1 kHz.

Inverting Amplifier

Build the Inverting amplifier discussed in the Operational Amplifiers handout. Use resistors of your choice to create an amplifier with whatever gain you want, but choose values in the 100 Ω to 1 M Ω range. (I suggest a gain ≤ 10 or you won’t be able to get a small enough signal from the 33120 function generator to keep the circuit from clipping.) Draw your circuit in your lab notebook. Apply an input signal and confirm that the output is now inverted (upside down, or 180° out of phase) with respect to the input. Measure the voltage gain and compare to expectations.

One More Op-amp Circuit

Build another one of the circuits discussed in the Operational Amplifiers handout (any one you want). If you make the summer, make it with just two inputs and either use the “+5V” output of the DC supply as your second input or check-out a second signal generator. If you make the differentiator, I suggest $C = 0.22 \mu\text{F}$ (224) capacitor $R_{in} = 10 \text{ k}\Omega$. If you make the integrator, I suggest $C = 0.22 \mu\text{F}$ (224) capacitor $R_{in} = 1 \text{ k}\Omega$ and $R_f = 100 \text{ k}\Omega$.

Draw your circuit in your lab notebook. Devise tests which will measure the important properties of your circuits. (Does the circuit do what it should do and is the output the right amplitude for the given input?) Compare your measurements to calculated expectations.

Servo

Look at the servo schematic (attached to last week’s lab). It uses at least two of the circuits shown in the Operational Amplifiers handout. Determine which circuits and label them on the big schematic (or a new one from your TA or website). The LM324 on the servo contains 4 op-amps. The output pin numbers are 1, 7, 8, & 14 (see the first figure on page 1 of this lab). Look at the schematic and determine which op-amp is lower-left, which is the lower-right, which is the upper-left, etc. Label them on the schematic as LL, LR, UL, and UR. Tape the schematic into your lab notebook (probably as a foldout).

The last op-amp, connected to the transistors, has a voltage gain of 1. The first three op-amps have a variable gain, depending on the position of the gain knob. The two voltage inputs to the circuit are the center connections of the two position sensor potentiometers. If you consider the input to be the difference of these two voltages and the output to be the motor voltage. Determine the minimum voltage gain from the component values given on the schematic and the gain expressions given in the op-amp handout. Determine the maximum gain.

Turn the gain pot on the servo to minimum gain (fully CCW). Turn on the function generator and reduce the signal amplitude until it shows 50 mVpp (actually output is 100 mVpp). Find lab 9, the Control Systems lab in your lab notebook. That should tell you how to measure the gain of the servo. If you didn't document it well enough in your lab notebook, you may want to refer to the Control Systems lab handout. Use that method now to measure the minimum gain. Turn the gain pot on the servo to maximum gain (fully CW). Measure the maximum gain. Compare your measured values to those you calculated from the schematic.

Extra Credit

Build and test one or two more of the circuits in the Operational Amplifiers handout. Each circuit that you build, test, and document is worth up to 10 extra-credit points.

Conclude

Check off. Write a normal conclusion in your notebook. Comment on how some of these circuits might be used. You may not be able to see how they could *all* be used, but I expect you to be able to describe uses for at least a couple of them.

OK. That's it. Lab is over. I hope you got something out of it all. If you're an ME student, you'll see many more electrical and op-amp circuits in your Mechatronics labs, only those labs will be more fun, especially if you learned the basics in this lab.

