

Scan your homework and convert to a pdf file. Turn in on Canvas. Homework is due by 11:59 p.m. on the due date.

The following problems are not meant to be hard. You should be able to do most of them in your head with no special formulas or calculations. In fact you should find them rather dumb and trivial. That's the point, I want to drill these concepts into your head so that you'll find them easy.

1. The figure at right shows a hydraulic system with a pump that converts rotational energy to fluid energy and two turbines which convert that energy back to rotational energy. Do NOT assume that the turbines are equal in size. This is a closed system containing an incompressible fluid with no places for that fluid to collect; i.e. flow in = flow out of any point or object. Kirchhoff's current law applies. The volumetric fluid flows are indicated by the arrows.

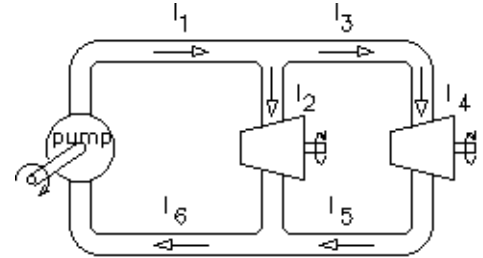

$$I_1 := 0.01 \cdot \frac{\text{m}^3}{\text{s}} \quad I_2 := 0.007 \cdot \frac{\text{m}^3}{\text{s}}$$

$$I_3 = \underline{\hspace{2cm}} \quad I_4 = \underline{\hspace{2cm}} \quad I_5 = \underline{\hspace{2cm}} \quad I_6 = \underline{\hspace{2cm}}$$

2. The figure at right shows an electrical circuit with a battery that converts chemical energy to electrical energy and two resistors which convert that electrical energy to heat energy. Do NOT assume that the resistors are equal in size. All electrical circuits are closed systems containing incompressible charges with no places for those charges to collect; i.e. flow in = flow out of any point or object. Kirchhoff's current law applies. The electrical currents are indicated by the arrows.

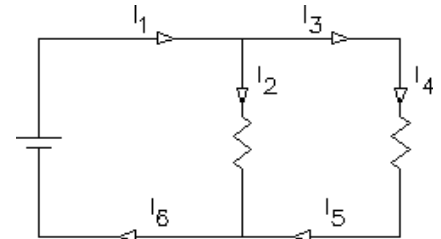

$$I_1 := 0.01 \cdot \text{A} \quad I_2 := 0.007 \cdot \text{A}$$

$$I_3 = \underline{\hspace{2cm}} \quad I_4 = \underline{\hspace{2cm}} \quad I_5 = \underline{\hspace{2cm}} \quad I_6 = \underline{\hspace{2cm}}$$

3. The figure at right shows a similar electrical circuit only now the electrical currents are indicated by the arrows next to the wires. This is a more common way to show the current flow because a little arrow in the wire is too easily confused with the electrical symbol for a diode. You'll learn about diodes later.

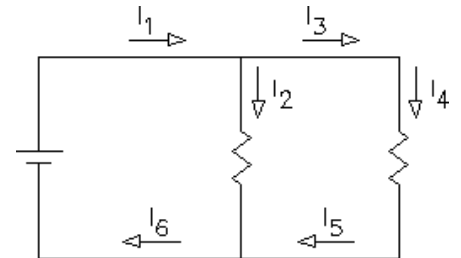

$$I_2 := 20 \cdot \text{mA} \quad I_5 := 14 \cdot \text{mA}$$

$$I_6 = \underline{\hspace{2cm}} \quad I_1 = \underline{\hspace{2cm}} \quad I_3 = \underline{\hspace{2cm}} \quad I_4 = \underline{\hspace{2cm}}$$

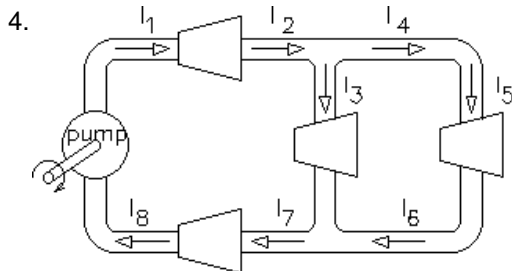

$$I_3 := 0.004 \cdot \frac{\text{m}^3}{\text{s}} \quad I_5 := 0.001 \cdot \frac{\text{m}^3}{\text{s}} \quad I_4 = \underline{\hspace{2cm}}$$

$$I_2 = \underline{\hspace{2cm}} \quad I_1 = \underline{\hspace{2cm}} \quad I_6 = \underline{\hspace{2cm}}$$

$$I_7 = \underline{\hspace{2cm}} \quad I_8 = \underline{\hspace{2cm}}$$

ECE 2210 / 00 homework DC1 p2

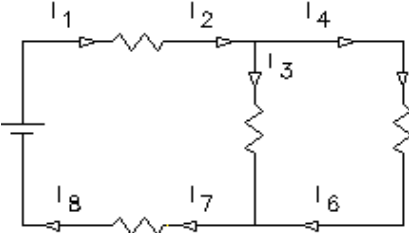
5.  $I_3 := 4.5 \cdot \text{mA}$ $I_5 := 1.2 \cdot \text{mA}$ $I_4 = \underline{\hspace{2cm}}$
 $I_2 = \underline{\hspace{2cm}}$ $I_1 = \underline{\hspace{2cm}}$ $I_6 = \underline{\hspace{2cm}}$
 $I_7 = \underline{\hspace{2cm}}$ $I_8 = \underline{\hspace{2cm}}$

6. Again, a similar electrical circuit with the electrical current arrows in the more common position, next to the wires.

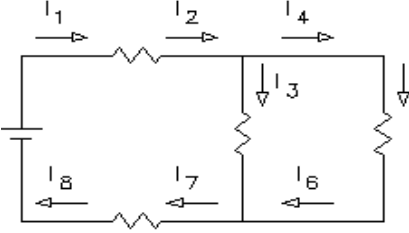
 $I_6 := 0.03 \cdot \text{A}$ $I_7 := 0.08 \cdot \text{A}$ $I_8 = \underline{\hspace{2cm}}$
 $I_1 = \underline{\hspace{2cm}}$ $I_2 = \underline{\hspace{2cm}}$ $I_3 = \underline{\hspace{2cm}}$
 $I_4 = \underline{\hspace{2cm}}$ $I_5 = \underline{\hspace{2cm}}$

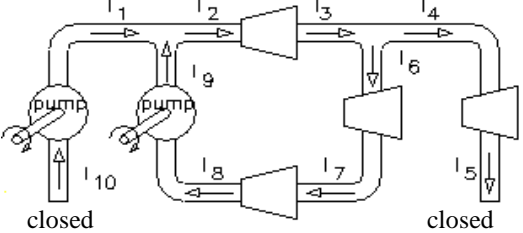
7.  $I_9 := 0.04 \cdot \frac{\text{m}^3}{\text{s}}$ $I_1 = \underline{\hspace{2cm}}$ $I_2 = \underline{\hspace{2cm}}$
 $I_3 = \underline{\hspace{2cm}}$ $I_4 = \underline{\hspace{2cm}}$ $I_5 = \underline{\hspace{2cm}}$
 $I_6 = \underline{\hspace{2cm}}$ $I_7 = \underline{\hspace{2cm}}$ $I_8 = \underline{\hspace{2cm}}$ $I_7 = \underline{\hspace{2cm}}$ $I_{10} = \underline{\hspace{2cm}}$

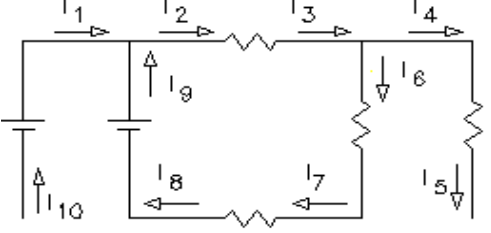
8.  $I_9 := 0.06 \cdot \text{A}$ $I_1 = \underline{\hspace{2cm}}$ $I_2 = \underline{\hspace{2cm}}$
 $I_3 = \underline{\hspace{2cm}}$ $I_4 = \underline{\hspace{2cm}}$ $I_5 = \underline{\hspace{2cm}}$
 $I_6 = \underline{\hspace{2cm}}$ $I_7 = \underline{\hspace{2cm}}$ $I_8 = \underline{\hspace{2cm}}$ $I_7 = \underline{\hspace{2cm}}$ $I_{10} = \underline{\hspace{2cm}}$

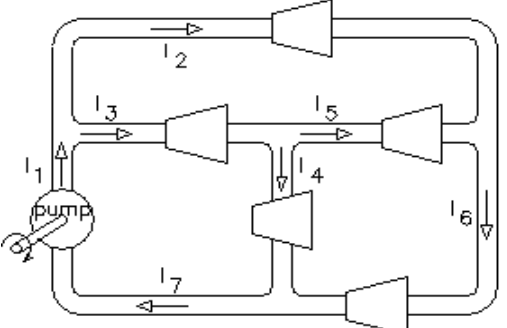
9.  $I_4 := 0.05 \cdot \frac{\text{m}^3}{\text{s}}$ $I_5 := 0.014 \cdot \frac{\text{m}^3}{\text{s}}$ $I_6 := 0.03 \cdot \frac{\text{m}^3}{\text{s}}$
 $I_1 = \underline{\hspace{2cm}}$ $I_2 = \underline{\hspace{2cm}}$
 $I_3 = \underline{\hspace{2cm}}$ $I_7 = \underline{\hspace{2cm}}$

ECE 2210 / 00 homework DC1 p3

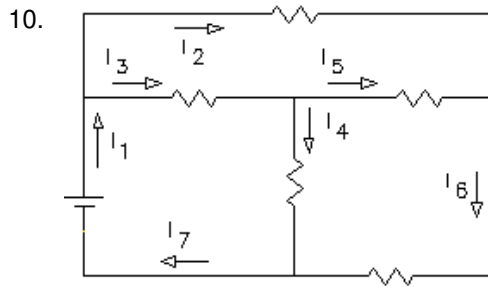

$$I_4 := 20 \cdot \text{mA} \quad I_5 := 10 \cdot \text{mA} \quad I_6 := 22 \cdot \text{mA}$$

$$I_1 = \underline{\hspace{2cm}} \quad I_2 = \underline{\hspace{2cm}}$$

$$I_3 = \underline{\hspace{2cm}} \quad I_7 = \underline{\hspace{2cm}}$$

11. Careful here, there are now two pumps. Also, given the flow arrows shown, one or more of the flows must come out **negative**.

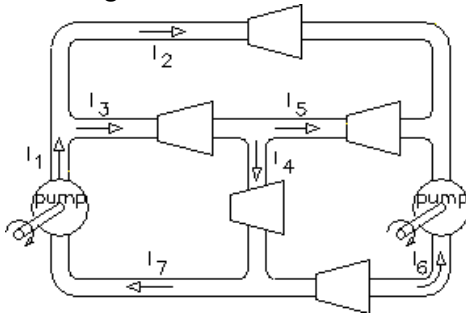

$$I_2 := 0.005 \cdot \frac{\text{m}^3}{\text{s}} \quad I_6 := 0.03 \cdot \frac{\text{m}^3}{\text{s}} \quad I_7 := 0.015 \cdot \frac{\text{m}^3}{\text{s}}$$

$$I_1 = \underline{\hspace{2cm}} \quad I_3 = \underline{\hspace{2cm}}$$

$$I_4 = \underline{\hspace{2cm}} \quad I_5 = \underline{\hspace{2cm}}$$

12. What does a negative fluid flow physically mean?

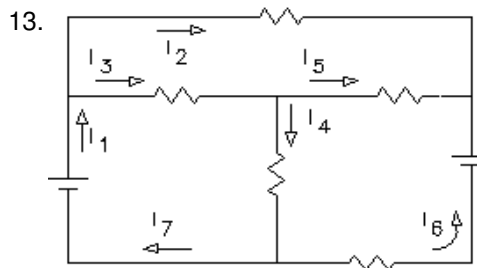

$$I_1 := 0.01 \cdot \text{A} \quad I_5 := -20 \cdot \text{mA} \quad I_6 := 35 \cdot \text{mA}$$

$$I_2 = \underline{\hspace{2cm}} \quad I_3 = \underline{\hspace{2cm}}$$

$$I_4 = \underline{\hspace{2cm}} \quad I_7 = \underline{\hspace{2cm}}$$

14. What does a negative electrical current physically mean?

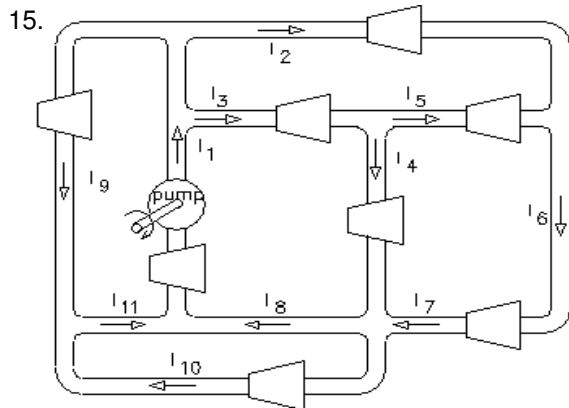

$$I_4 := 0.05 \cdot \frac{\text{m}^3}{\text{s}} \quad I_5 := 0.03 \cdot \frac{\text{m}^3}{\text{s}} \quad I_7 := 0.045 \cdot \frac{\text{m}^3}{\text{s}}$$

$$I_9 := 0.06 \cdot \frac{\text{m}^3}{\text{s}} \quad I_1 = \underline{\hspace{2cm}}$$

$$I_2 = \underline{\hspace{2cm}} \quad I_3 = \underline{\hspace{2cm}}$$

$$I_6 = \underline{\hspace{2cm}} \quad I_8 = \underline{\hspace{2cm}}$$

$$I_{10} = \underline{\hspace{2cm}} \quad I_{11} = \underline{\hspace{2cm}}$$

ECE 2210 / 00 homework DC1 p4

16.

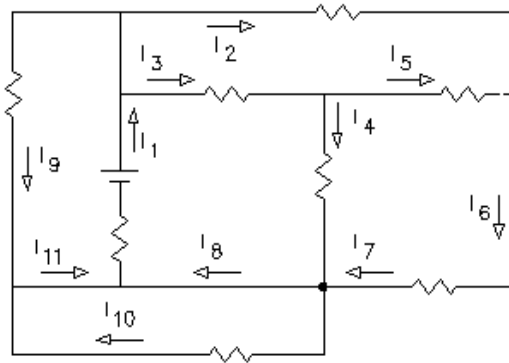

$I_1 := 100\text{ mA}$

$I_2 := 50\text{ mA}$

$I_3 := 30\text{ mA}$

$I_6 := 66\text{ mA}$

$I_4 = \underline{\hspace{2cm}}$

$I_5 = \underline{\hspace{2cm}}$

$I_7 = \underline{\hspace{2cm}}$

$I_8 = \underline{\hspace{2cm}}$

$I_9 = \underline{\hspace{2cm}}$

$I_{10} = \underline{\hspace{2cm}}$

$I_{11} = \underline{\hspace{2cm}}$

17. The figure at right shows the pressure differentials across elements in a hydraulic system. The side indicated by the + sign is the higher pressure side. Conversely, - indicates the lower pressure. ΔP_S is the pressure difference supplied by the pump (S for Source). ΔP_2 is the pressure difference driving the left turbine and ΔP_4 is the pressure difference driving the right turbine. Assume no pressure losses or discontinuities in the pipes, joints, or corners; i.e. all connected pipes are at exactly the same pressure. Finally, the fluid has no mass, so gravity and Bernoulli can go take a hike.

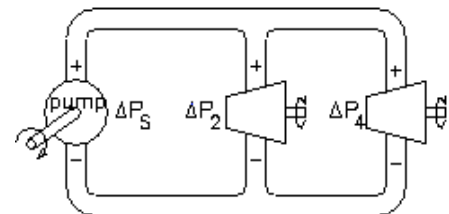

$\Delta P_S := 12 \cdot \frac{\text{N}}{\text{m}^2} = 12 \cdot \text{Pa}$

$\Delta P_2 = \underline{\hspace{2cm}}$

$\Delta P_4 = \underline{\hspace{2cm}}$

Yes, I know that these are ridiculously low pressures for a hydraulic system.

18. The figure at right shows the voltage differentials across elements in an electrical circuit. The side indicated by the + sign is the higher voltage side. Conversely, - indicates the lower voltage. V_S is the voltage supplied by the battery. V_2 is the voltage across the left resistor and V_4 is the voltage across the right resistor. You may assume no voltage drops across any of the wires or connections in practically *all* electrical schematics; i.e. all connected wires are at exactly the same voltage (electrical potential).

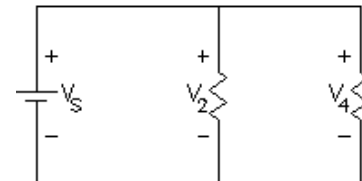

$V_S := 12\text{ V}$ (V = volts)

$V_2 = \underline{\hspace{2cm}}$

$V_4 = \underline{\hspace{2cm}}$

19.

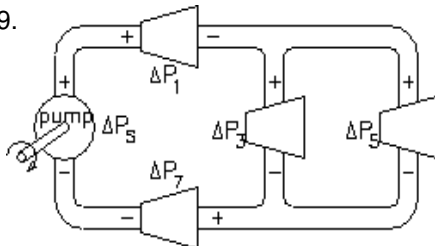

$\Delta P_S := 400\text{ kPa}$

$\Delta P_1 := 180\text{ kPa}$

$\Delta P_3 := 100\text{ kPa}$

$\Delta P_5 = \underline{\hspace{2cm}}$

$\Delta P_7 = \underline{\hspace{2cm}}$

20.

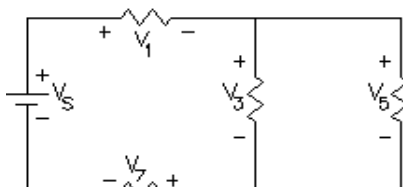

$V_1 := 10\text{ V}$

$V_5 := 3\text{ V}$

$V_7 := 2\text{ V}$

$V_S = \underline{\hspace{2cm}}$

$V_3 = \underline{\hspace{2cm}}$

ECE 2210 / 00 homework DC1 p5

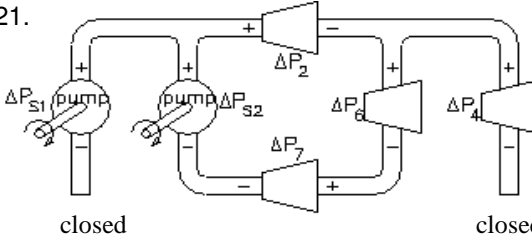
21.  $\Delta P_{S1} := 200 \cdot \text{kPa}$ $\Delta P_{S2} := 150 \cdot \text{kPa}$ $\Delta P_2 := 50 \cdot \text{kPa}$ $\Delta P_6 := 60 \cdot \text{kPa}$

$\Delta P_4 = \underline{\hspace{2cm}}$ $\Delta P_7 = \underline{\hspace{2cm}}$

closed closed

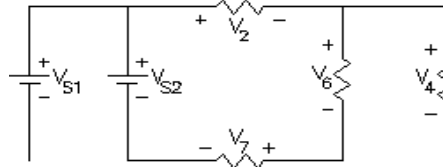
22.  $V_{S1} := 6 \cdot \text{V}$ $V_2 := 2 \cdot \text{V}$ $V_6 := 2.4 \cdot \text{V}$ $V_7 := 3.2 \cdot \text{V}$

$V_{S2} = \underline{\hspace{2cm}}$ $V_4 = \underline{\hspace{2cm}}$

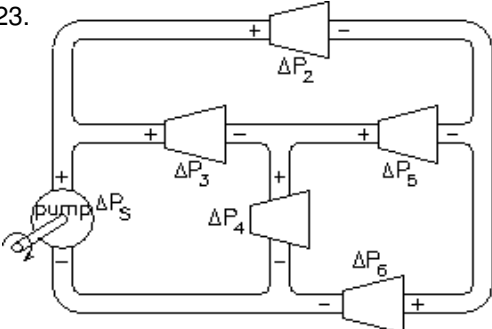
23.  $\Delta P_3 := 120 \cdot \text{kPa}$ $\Delta P_4 := 80 \cdot \text{kPa}$ $\Delta P_6 := 110 \cdot \text{kPa}$

$\Delta P_S = \underline{\hspace{2cm}}$ $\Delta P_2 = \underline{\hspace{2cm}}$

$\Delta P_5 = \underline{\hspace{2cm}}$

24. What does a negative pressure difference physically mean?

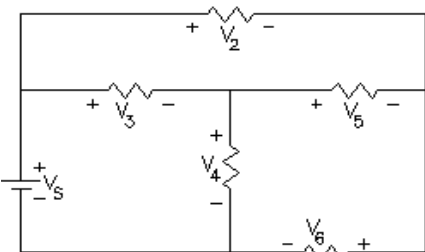
25.  $V_3 := 2.3 \cdot \text{V}$ $V_5 := 0.5 \cdot \text{V}$ $V_6 := 3.2 \cdot \text{V}$

$V_S = \underline{\hspace{2cm}}$ $V_2 = \underline{\hspace{2cm}}$

$V_4 = \underline{\hspace{2cm}}$

26. Watch your + and - signs very carefully now.

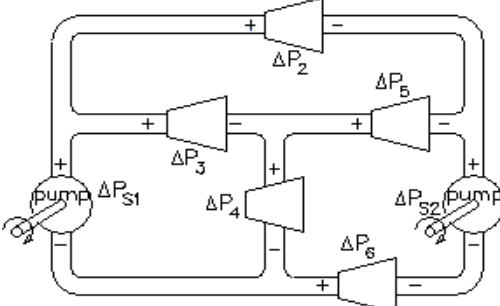
 $\Delta P_2 := 140 \cdot \text{kPa}$ $\Delta P_3 := 230 \cdot \text{kPa}$ $\Delta P_4 := 50 \cdot \text{kPa}$ $\Delta P_6 := 210 \cdot \text{kPa}$

$\Delta P_{S1} = \underline{\hspace{2cm}}$ $\Delta P_{S2} = \underline{\hspace{2cm}}$

$\Delta P_5 = \underline{\hspace{2cm}}$

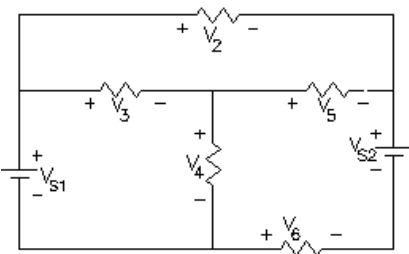
27.  $V_{S1} := 14 \cdot \text{V}$ $V_{S2} := 3 \cdot \text{V}$ $V_2 := 6 \cdot \text{V}$ $V_3 := 4 \cdot \text{V}$

$V_4 = \underline{\hspace{2cm}}$ $V_5 = \underline{\hspace{2cm}}$

$V_6 = \underline{\hspace{2cm}}$

Think about the current through the 2nd battery. What is happening to that battery?

ECE 2210 / 00 homework DC1 p6

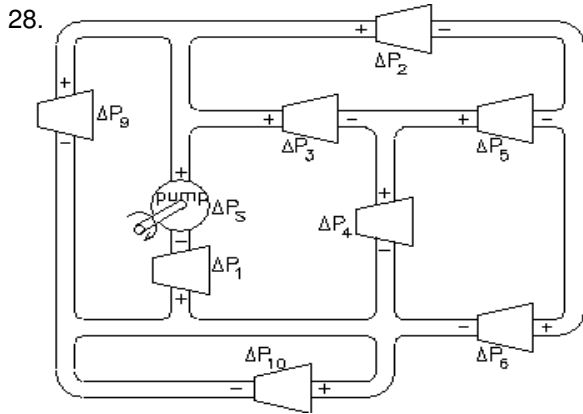

$$\begin{aligned} \Delta P_1 &:= 200 \cdot \text{kPa} & \Delta P_2 &:= 1100 \cdot \text{kPa} \\ \Delta P_3 &:= 600 \cdot \text{kPa} & \Delta P_9 &:= 1800 \cdot \text{kPa} \\ \Delta P_S &= \underline{\hspace{2cm}} & \Delta P_4 &= \underline{\hspace{2cm}} \\ \Delta P_5 &= \underline{\hspace{2cm}} & \Delta P_6 &= \underline{\hspace{2cm}} \\ \Delta P_{10} &= \underline{\hspace{2cm}} \end{aligned}$$

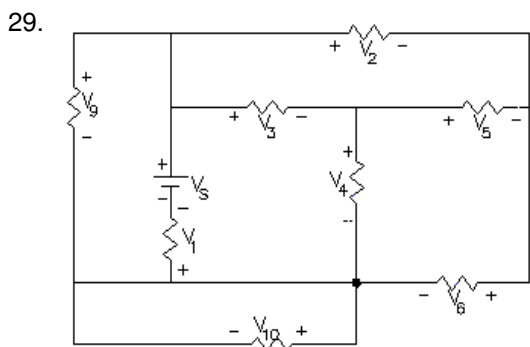

$$\begin{aligned} V_S &:= 18 \cdot \text{V} & V_3 &:= 6 \cdot \text{V} & V_4 &:= 8 \cdot \text{V} & V_5 &:= 2 \cdot \text{V} \\ V_1 &= \underline{\hspace{2cm}} & V_2 &= \underline{\hspace{2cm}} \\ V_6 &= \underline{\hspace{2cm}} & V_9 &= \underline{\hspace{2cm}} \\ V_{10} &= \underline{\hspace{2cm}} \end{aligned}$$

Answers

1. $I_3 = I_4 = I_5 := 0.003 \cdot \frac{\text{m}^3}{\text{s}}$, $I_6 := 0.01 \cdot \frac{\text{m}^3}{\text{s}}$
2. $I_3 = I_4 = I_5 := 0.003 \cdot \text{A}$, $I_6 := 0.01 \cdot \text{A}$
3. $I_6 = I_1 := 34 \cdot \text{mA}$, $I_3 = I_4 := 14 \cdot \text{mA}$
4. $I_4 = I_6 := 0.001 \cdot \frac{\text{m}^3}{\text{s}}$, $I_1 = I_2 = I_7 = I_8 := 0.005 \cdot \frac{\text{m}^3}{\text{s}}$
5. $I_4 = I_6 := 1.2 \cdot \text{mA}$, $I_1 = I_2 = I_7 = I_8 := 5.7 \cdot \text{mA}$
6. $I_1 = I_2 = I_8 := 80 \cdot \text{mA}$, $I_3 := 50 \cdot \text{mA}$, $I_4 = I_5 := 30 \cdot \text{mA}$
7. $I_1 = I_{10} = I_4 = I_5 := 0 \cdot \frac{\text{m}^3}{\text{s}}$, $I_2 = I_3 = I_7 = I_8 := 0.04 \cdot \frac{\text{m}^3}{\text{s}}$
8. $I_1 = I_{10} = I_4 = I_5 := 0 \cdot \text{A}$,
 $I_2 = I_3 = I_7 = I_8 := 0.06 \cdot \text{A}$
9. $I_1 = I_7 := 0.080 \cdot \frac{\text{m}^3}{\text{s}}$, $I_2 := 0.016 \cdot \frac{\text{m}^3}{\text{s}}$, $I_3 := 0.064 \cdot \frac{\text{m}^3}{\text{s}}$
10. $I_1 = I_7 := 42 \cdot \text{mA}$, $I_2 := 12 \cdot \text{mA}$, $I_3 := 30 \cdot \text{mA}$
11. $I_1 := 0.015 \cdot \frac{\text{m}^3}{\text{s}}$, $I_3 := 0.010 \cdot \frac{\text{m}^3}{\text{s}}$, $I_4 := 0.045 \cdot \frac{\text{m}^3}{\text{s}}$, $I_5 := -0.035 \cdot \frac{\text{m}^3}{\text{s}}$
12. Actual flow is in direction opposite to the arrow direction.
13. $I_2 := -15 \cdot \text{mA}$, $I_3 := 25 \cdot \text{mA}$, $I_4 := 45 \cdot \text{mA}$, $I_7 := 10 \cdot \text{mA}$
14. "
15. $I_1 := 0.155 \cdot \frac{\text{m}^3}{\text{s}}$, $I_2 := 0.015 \cdot \frac{\text{m}^3}{\text{s}}$, $I_3 := 0.080 \cdot \frac{\text{m}^3}{\text{s}}$, $I_6 := 0.045 \cdot \frac{\text{m}^3}{\text{s}}$, $I_8 := 0.095 \cdot \frac{\text{m}^3}{\text{s}}$, $I_{10} := 0 \cdot \frac{\text{m}^3}{\text{s}}$, $I_{11} := 0.060 \cdot \frac{\text{m}^3}{\text{s}}$
16. $I_4 := 14 \cdot \text{mA}$, $I_5 := 16 \cdot \text{mA}$, $I_7 := 66 \cdot \text{mA}$, $I_8 := 80 \cdot \text{mA}$, $I_9 := 20 \cdot \text{mA}$, $I_{10} := 0 \cdot \text{mA}$, $I_{11} := 20 \cdot \text{mA}$
17. $\Delta P_2 = \Delta P_4 := 12 \cdot \text{Pa}$
18. $V_2 = V_4 := 12 \cdot \text{V}$
19. $\Delta P_5 := 100 \cdot \text{kPa}$, $\Delta P_7 := 120 \cdot \text{kPa}$
20. $V_S := 15 \cdot \text{V}$, $V_3 := 3 \cdot \text{V}$
21. $\Delta P_4 := 0 \cdot \text{kPa}$, $\Delta P_7 := 40 \cdot \text{kPa}$
22. $V_{S2} := 7.6 \cdot \text{V}$, $V_4 := 0 \cdot \text{V}$
23. $\Delta P_S := 200 \cdot \text{kPa}$, $\Delta P_2 := 90 \cdot \text{kPa}$, $\Delta P_5 := -30 \cdot \text{kPa}$
24. The actual + & - should be reversed from those on drawing
25. $V_S := 6 \cdot \text{V}$, $V_2 := 2.8 \cdot \text{V}$, $V_4 := 3.7 \cdot \text{V}$
26. $\Delta P_{S1} := 280 \cdot \text{kPa}$, $\Delta P_{S2} := 350 \cdot \text{kPa}$, $\Delta P_5 := -90 \cdot \text{kPa}$
27. $V_4 := 10 \cdot \text{V}$, $V_5 := 2 \cdot \text{V}$, $V_6 := -5 \cdot \text{V}$ battery is charging
28. $\Delta P_S := 2000 \cdot \text{kPa}$, $\Delta P_4 := 1200 \cdot \text{kPa}$, $\Delta P_5 := 500 \cdot \text{kPa}$,
 $\Delta P_6 := 700 \cdot \text{kPa}$, $\Delta P_{10} := 0 \cdot \text{kPa}$
29. $V_1 := 4 \cdot \text{V}$, $V_2 := 8 \cdot \text{V}$, $V_6 := 6 \cdot \text{V}$, $V_9 := 14 \cdot \text{V}$, $V_{10} := 0 \cdot \text{V}$